

EDB6032_G/GB
00376698

Lenze

Antriebstechnik

Operating Instructions

Brake chopper
6032/6033/6034



These operating instructions are valid for the devices with the nameplate data:

6032_G.2E
6033_G.2E
6034_G.1A

Type

Built-in device IP00

Hardware version +
index

Corrected edition of: 09.01.1995

Date of print: 16.01.1995

How to use these Operating Instructions...

To locate information on specific topics, simply refer to the table of contents at the beginning of these Operating Instructions.

These Operating Instructions use a series of different symbols to provide quick reference and to highlight important items.

This symbol refers to items of information intended to facilitate operation.



Notes which should be observed to avoid possible damage to or destruction of equipment.



Notes which should be observed to avoid health risks to the operating personnel.





Safety information

The equipment described is intended for use in industrial drive systems.

This equipment can endanger life through rotating machinery and high voltages, therefore it is essential that guards for both electrical and mechanical parts are not removed.

The following points should be observed for the safety of the personnel:

- Only qualified personnel familiar with the equipment are permitted to install, operate and maintain the devices
- System documentation must be available and observed at all times.
- All non-qualified personnel must be kept at a safe distance from the equipment.
- The system must be installed in accordance with local regulations.

A qualified person is someone who is familiar with all safety notes and established safety practices, with the installation, operation and maintenance of this equipment and the hazards involved. For more detailed definitions see IEC 364.

These safety notes do not represent a complete list of the steps necessary to ensure safe operation of the equipment. For further information, please contact your nearest Lenze representative.

The information given in these Operating Instructions only apply to the hardware and software versions that are indicated on the cover page. If the version of your equipment is not listed these Operating Instructions must not be used. Lenze cannot be held responsible for any malfunction resulting from the above.

The specifications, processes and circuitry described in these Operating Instructions are for guidance only and must be adapted to your own specific applications. Lenze does not guarantee the suitability of the processes and circuitry described in these Operating Instructions for individual applications.

The specifications in these Operating Instructions describe the features of the products without guarantee.

Lenze personnel have carefully checked these Operating Instructions and the equipment described, but cannot be held responsible for its accuracy.

Content

1.	Features	4
1.1.	Scope of delivery	4
2.	Technical data	4
3.	Dimensions and installation	5
3.1.	Installation of brake choppers	5
3.2.	Dimensions	5
4.	Selection of the brake resistors	6
4.1.	Selection tables for brake resistors	7
4.2.	Dimensions of brake resistors	8
4.2.1.	Resistor with integrated temperature monitoring (50 to 200W)	8
4.2.2.	Screened wire-wound resistors equipped with integrated temperature monitoring (300 and 600W)	8
4.3.	Brake chopper connection	9
4.3.1.	Brake chopper 6032G with frequency inverters 8201-8204	9
4.3.2.	Brake choppers 6033G and 6034G with frequency inverters 8211-8216	10
5.	Operation	11
5.1.	Parallel connection of brake choppers	11
6.	Accessories	11

1. Features

The brake choppers 6032, 6033 und 6034 are additional components for frequency inverters with DC bus.

In generator mode, e.g. during deceleration of the drive, the machine feeds back energy into the DC bus of the controller. If, as a result, the DC bus voltage exceeds the maximum permissible value, pulse inhibit will be set and "Overvoltage" will be displayed. As soon as the voltage falls below this maximum permissible value, the controller will be enabled again.

- Enclosure IP00 for cabinet assembly
- Assembly on DIN rails, alternatively assembly on module resistors
- Dissipation of brake energy in form of heat
- Very short brake times possible
- If not defined, the controller will not set pulse inhibit during braking

1.1. Scope of delivery

- Brake chopper
- Snap-on assembly kit for DIN rails
- Operating Instructions

2. Technical data

Brake chopper	6032_G	6033_G	6034_G
Order no.	33.6032_G	33.6033_G	33.6034_G
Article no.	340 917	340 918	366 190
Supply voltage	270-380VDC	470-660VDC	520-730VDC
Switching threshold	375VDC	650VDC	725VDC
Permanent brake power	1.5kW	2.6kW	2.6kW
Peak brake power	3.0kW	5.1kW	5.1kW
Max. brake energy	60kWs	100kWs	100kWs
Smallest brake resistor	47Ω	82Ω	100Ω
Temperature range	0 - 45°C		
Storage temperature	-20°C to +70°C		
Humidity	Humidity class G to DIN 40040 max. 85%, no condensation		

The following brake chopper types are available:

- 6032G:
For frequency inverters with single-phase mains connection (V_{rated} 230V~) e.g. 8201-8204.
- 6033G:
For frequency inverters with three-phase mains connection (V_{rated} 400V~) e.g. B. 8211-8216.
- 6034G:
For frequency inverters with three-phase mains connection (V_{rated} 460V~ for application in e.g. USA) e.g. 8211-8215.

3. Dimensions and installation

3.1. Installation of brake choppers

The housing must be assembled vertically, terminals at the bottom. To ensure the unimpeded cooling air circulation, a free space of 100 mm at the top and the bottom is required. The ambient temperature may not exceed +45°C.

3.2. Dimensions

Dimension of the brake chopper:

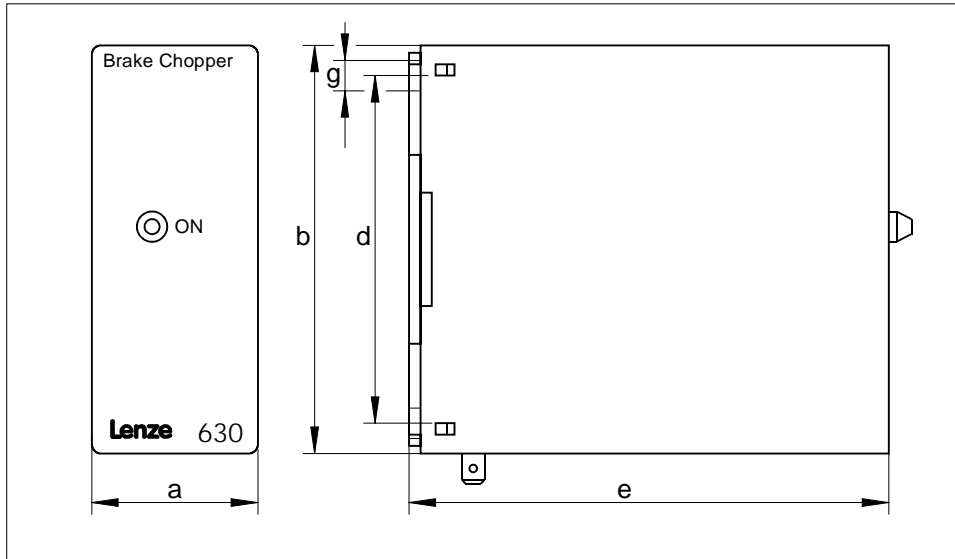

Brake chopper					
Type	a mm	b mm	d mm	e mm	g mm
6032_G	45	109	95	127	4.5
6033_G					
6034_G					



4. Selection of the brake resistors

The resistance is calculated as follows:

$$\text{Resistance } [\Omega] = \frac{(\text{Threshold})^2 \text{ [V]}^2}{\text{required peak power [W]}}$$

The value may not fall below the minimum resistance of the brake chopper. Otherwise, the unit might be destroyed.

After having calculated the resistance, determine the rated power of the brake resistor for cyclic braking operation.

For most applications, the brake time remains under 15s. In cyclic braking operations, the relative ON period does not exceed max. 10%.

$$\text{Rated power [W]} = \frac{\text{ON period [s]}}{\text{Cycle time [s]}} \cdot \text{required peak brake power [W]}$$

For single or cyclic braking operations the heat capacity of the brake resistor is calculated as follows:

$$\text{Heat capacity [kWs]} = \text{ON period [s]} \cdot \text{required peak brake power [W]}$$

To avoid a thermal overload of the resistor, the heat capacity of the brake resistor must be considered (if necessary please contact the manufacturer).



Brake resistors may reach surface temperatures of up to 350°C. Therefore the resistors mentioned above are equipped with temperature monitoring. When using other brake resistors, an appropriate overcurrent/overtemperature protection, e.g. thermal overcurrent sensors, must be provided.

The thermostats of the brake resistors should be used to disconnect the inverter from the mains in case of overheating (see pages 9 and 10).

4.1. Selection tables for brake resistors

Selection table for frequency inverters with a mains voltage of 190...260V (6032G):

Rated motor power/kW	Brake resistor			
	Resistance/ Ω	Continuous power/W	Order no.	Article no.
0.37	470	50	ERBM470R050W	360115
0.75	200	100	ERBM200R100W	360114
1.5	100	150	ERBM100R150W	360113
2.2	82	200	ERBM082R200W	360112

Selection table for frequency inverters with a mains voltage of 330...450V (6033G):

Rated motor power/kW	Brake resistor			
	Resistance/ Ω	Continuous power/W	Order no.	Article no..
0.75	470	100	ERBM470R050W	361839
1.5	370	150	ERBM370R150W	357872
2.2	240	200	ERBM240R200W	357874
3.0	180	300	ERBD180R300W	357875
4.0	100	600	ERBD100R600W	357876
5.5	82	600	ERBD082R600W	365902

Selection table for frequency inverters with a mains voltage of 370...510V (6034G):

Rated motor power/kW	Brake resistor			
	Resistance/ Ω	Continuous power/W	Order no.	Article no..
0.75	470	100	ERBM470R050W	361839
1.5	370	150	ERBM370R150W	357872
2.2	240	200	ERBM240R200W	357874
3.0	180	300	ERBD180R300W	357875
4.0	100	600	ERBD100R600W	357876

All brake resistors are equipped with integrated temperature protection which must be used as safety protection (see pages 9 and 10).

When using other brake resistors, appropriate overcurrent/overtemperature protection, e.g. thermal overcurrent sensors etc. must be provided.



4.2. Dimensions of brake resistors

4.2.1. Resistor with integrated temperature monitoring (50 to 200W)

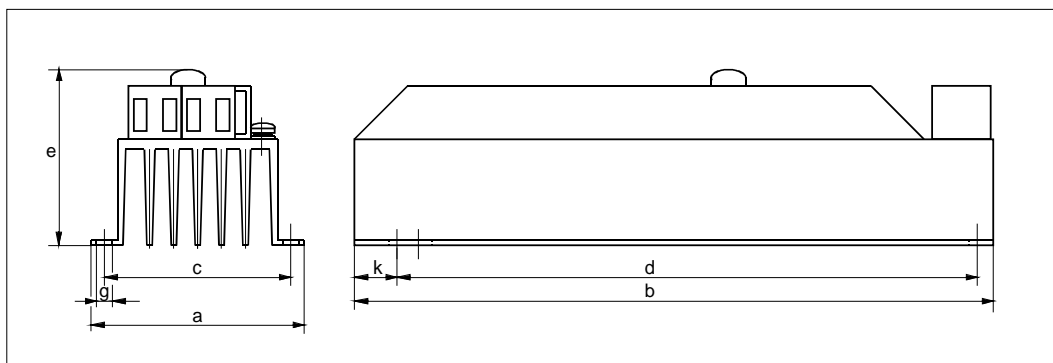

P/W	R/Ω	Order no.	a mm	b mm	c mm	d mm	e mm	g mm	k mm
50	470	ERBM470R050W	60	240	50	225	60	5	7.5
100	470	ERBM470R100W	70	240	50	225	60	5	7.5
100	200	ERBM200R100W	80	160	70	145	95	5	7.5
150	370	ERBM370R150W	80	240	70	225	95	5	7.5
150	100	ERBM100R150W	80	240	70	225	95	5	7.5
200	240	ERBM240R200W	80	340	70	325	70	5	7.5
200	82	ERBM082R200W	80	340	70	325	70	5	7.5

4.2.2. Screened wire-wound resistors equipped with integrated temperature monitoring (300 and 600W)

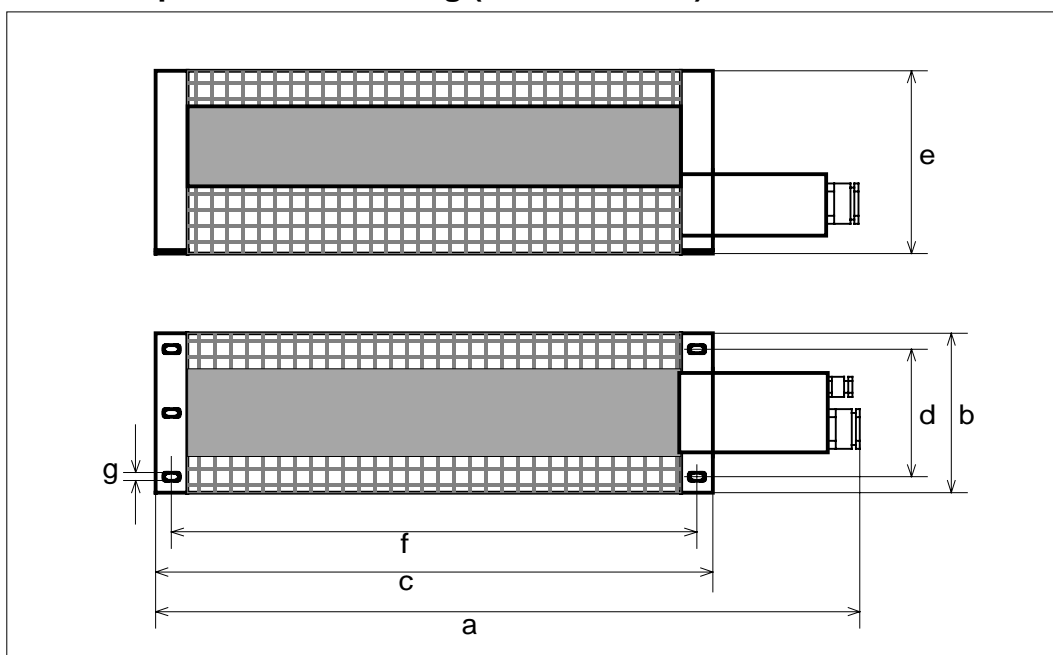

P/W	R/Ω	Order no.	a mm	b mm	c mm	d mm	e mm	f mm	k mm
300	180	ERBD180R300W	479	89	430	64	115	326	13
600	100	ERBM100R600W	579	89	530	64	115	426	13
600	82	ERBM082R600W	579	89	530	64	115	426	13

4.3. Brake chopper connection

4.3.1. Brake chopper 6032G with frequency inverters 8201-8204

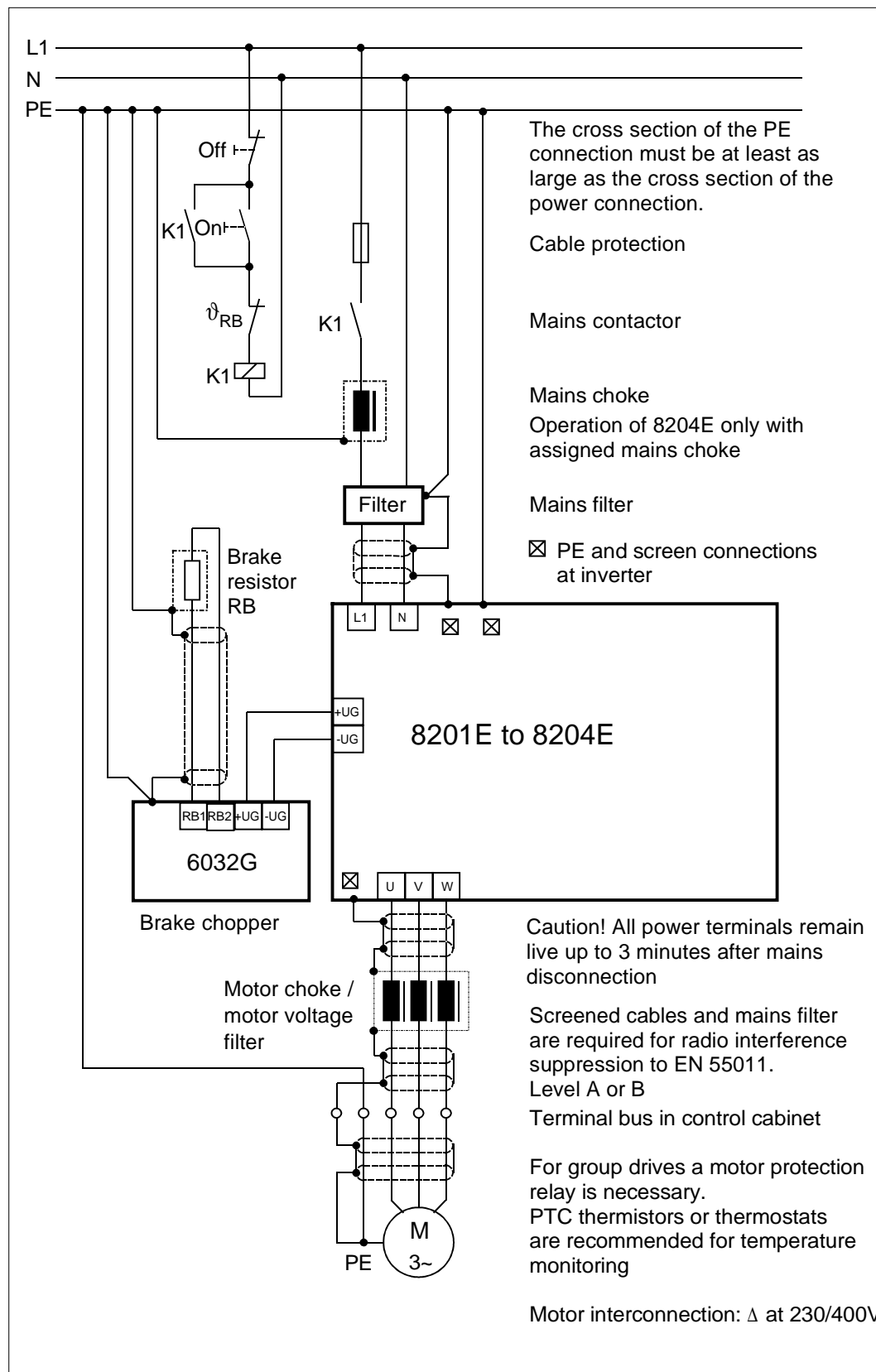

4.3.2. Brake choppers 6033G and 6034G with frequency inverters 8211-8216

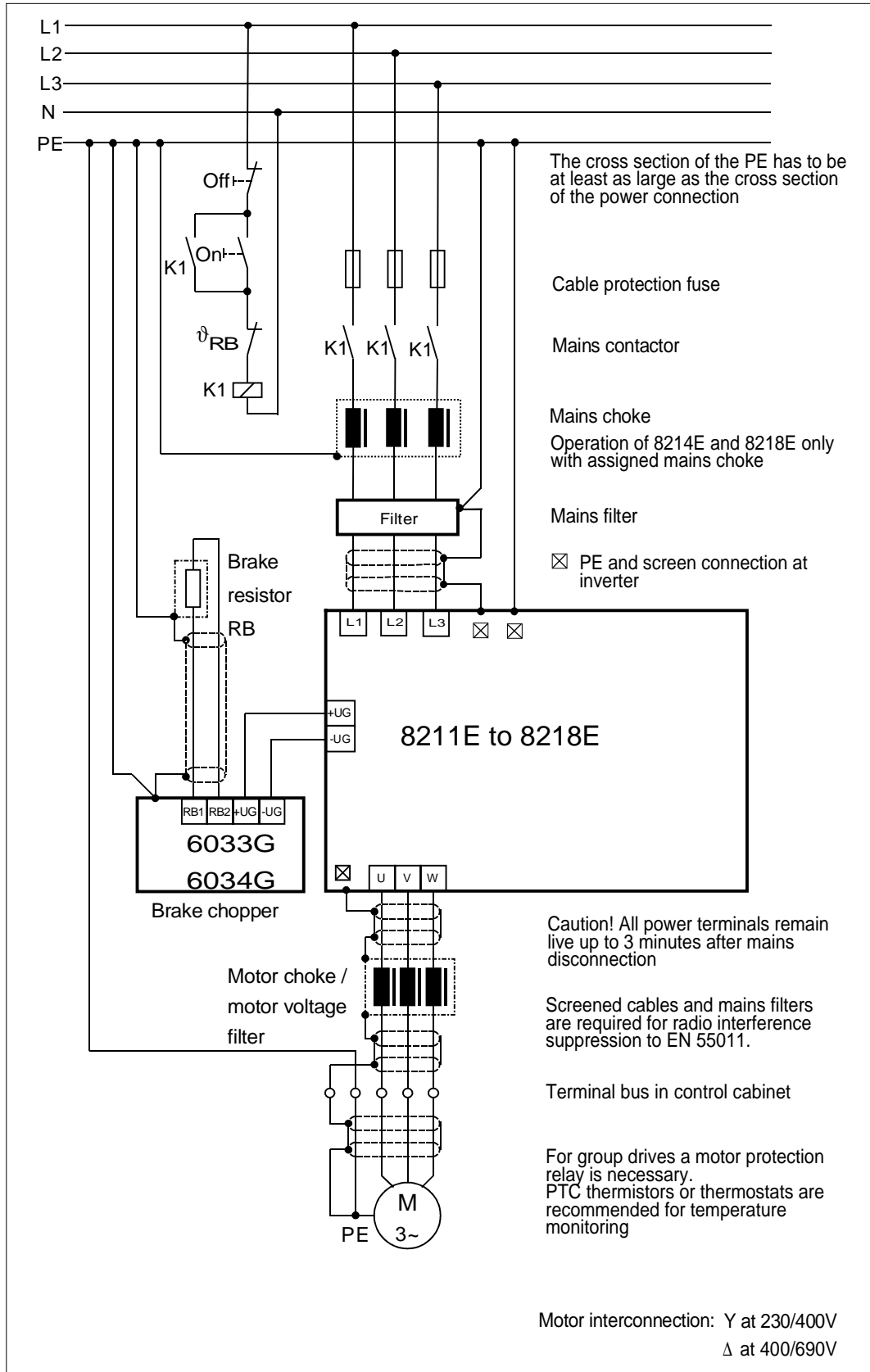

5. Operation

- It is absolutely necessary to check the connection of the terminals $+U_G$ and $-U_G$. Incorrect connection may cause destruction of the brake chopper and the frequency inverter.
- In case of mains overvoltage the brake chopper may be activated. When using resistors without overload protection the resistor may be destroyed. Therefore, only resistors equipped with integrated or external temperature monitoring must be fitted.
- All brake resistors recommended by Lenze are equipped with an integrated temperature monitoring.
- Due to the application of the brake chopper, the inverter exactly follows the programmed deceleration time. However, if the feedback power exceeds the peak power of the assigned brake resistor, the inverter will be inhibited and will display "Overvoltage". This results in an uncontrolled prolongation of the deceleration time. To overcome this problem, you must either prolong the Tif time or, if possible, select a lower-value brake resistor.
- LED ON (yellow) indicates the release of the brake chopper.

5.1. Parallel connection of brake choppers

With high brake powers it may be necessary to reduce the brake resistance to the minimum permissible value (see table page 7). If this is not enough, two brake choppers can be connected to double the peak power. In this case, please note the following:

- Each brake chopper must be separately connected to $+U_G$ and $-U_G$ of the frequency inverter.
- Each brake chopper must be connected to a separate brake resistor (terminals RB1 and RB2).
- The thermostats of the brake resistors (break contacts) must be connected in series.
- The lowest resistance must not be smaller than the one indicated in the Technical Data of the specific brake chopper.

6. Accessories

The brake chopper can also be assembled on module resistors by means of an assembly kit. This kit can be ordered under the order no. ER00370969.



