

SIEMENS

MICROMASTER Vector MIDIMASTER Vector

Operating Instructions



Contents

SAFETY INSTRUCTIONS	4
1. OVERVIEW	6
2. INSTALLATION - MICROMASTER Vector	12
3. INSTALLATION - MIDIMASTER Vector	25
4. CONTROLS AND BASIC OPERATION	32
5. OPERATING MODES	36
6. SYSTEM PARAMETERS	41
7. FAULT AND WARNING CODES	65
8. SPECIFICATIONS	67
9. SUPPLEMENTARY INFORMATION	73

Contents		Valid for
	MICROMASTER Vector firmware version	V2.08
	MIDIMASTER Vector firmware version	V2.07
1	Overview	6
1.1	Installation - General Notes	7
1.2	Wiring Guidelines to Minimise the Effects of EMI	8
1.3	Electrical Installation - General Notes	10
1.3.1	Operation with Unearthed (IT) Supplies	10
1.3.2	Operation with Residual Current Device (RCD)	10
1.3.3	Installation After a Period of Storage	10
1.3.4	Operation with Long Cables	11
2	Installation – MICROMASTER Vector	12
2.1	Mechanical Installation	12
2.2	Electrical Installation	15
2.2.1	Power and Motor Connections - Frame Size A	17
2.2.2	Power and Motor Connections - Frame Size B	18
2.2.3	Power and Motor Connections - Frame Size C	20
2.2.4	Control Connections	22
2.2.5	External Motor Thermal Overload Protection	23
2.2.6	Block Diagram – MICROMASTER Vector	24
3	Installation – MIDIMASTER Vector	25
3.1	Mechanical Installation	25
3.2	Electrical Installation	28
3.2.1	Power and Motor Connections	29
3.2.2	Control Connections	30
3.2.3	Motor Overload Protection	30
3.2.4	Block Diagram – MIDIMASTER Vector	31
4	Controls and Basic Operation	32
4.1	Controls	32
4.1.2	DIP Selector Switches	33
4.2	Basic Operation	34
4.2.1	General	34
4.2.2	Initial Testing	34
4.2.3	Basic Operation – 10 Step Guide	35

5	Operating Modes	36
5.1	Digital Control	36
5.2	Analogue Control	36
5.3	Motor Control Modes	36
5.3.1	Linear Voltage to Frequency (V/f) (P077= 0 or 2)	37
5.3.2	Flux Current Control (FCC) Operation (P077 = 1)	37
5.3.3	Sensorless Vector Control (SVC) Operation (P077 = 3)	37
5.4	Stopping the Motor	38
5.5	If the Motor Does Not Start Up	38
5.6	Local and Remote Control	38
5.7	Closed Loop Control	39
5.7.1	General Description	39
5.7.2	Hardware Set-up	40
5.7.3	Parameter Settings	40
6	System Parameters	41
7	Fault and Warning Codes	65
7.1	Fault Codes	65
7.2	Warning Codes	66
8	Specifications	67
9	Supplementary Information	73
9.1	Application Example	73
9.2	USS Status Codes	73
9.3	Electro-Magnetic Compatibility (EMC)	74
9.4	Environmental Aspects	77
9.5	User's Parameter Settings	78

Safety Instructions

Before installing and putting this equipment into operation, please read these safety instructions and warnings carefully and all the warning signs attached to the equipment. Make sure that the warning labels are kept in a legible condition and replace missing or damaged labels.



WARNING



This equipment contains dangerous voltages and controls dangerous rotating mechanical parts. Loss of life, severe personal injury or property damage can result if the instructions contained in this manual are not followed.

Only suitable qualified personnel should work on this equipment, and only after becoming familiar with all safety notices, installation, operation and maintenance procedures contained in this manual. The successful and safe operation of this equipment is dependent upon its proper handling, installation, operation and maintenance.

- The MICROMASTER and MIDIMASTER Vector units operate at high voltages.
- Only permanently-wired input power connections are allowed. This equipment must be grounded (IEC 536 Class 1, NEC and other applicable standards).
- If a Residual Current-operated protective Device (RCD) is to be used it must be an RCD type B.
- The dc-link capacitor remains charged to dangerous voltages even when the power is removed. For this reason it is not permissible to open the equipment until five minutes after the power has been turned off. When handling the open equipment it should be noted that live parts are exposed. Do not touch these live parts.
- Machines with a three phase power supply, fitted with EMC filters, must not be connected to a supply via an ELCB (Earth Leakage Circuit-Breaker - see *DIN VDE 0160, section 6.5*).
- The following terminals can carry dangerous voltages even if the inverter is inoperative:
 - the power supply terminals L/L1, N/L2 and L3 (MMV) - L1, L2, and L3 (MDV).
 - the motor terminals U, V, W.
 - the braking resistor terminals B+/DC+ and B-(MMV).
 - the braking unit terminals DC+ and DC- (MDV).
- Only qualified personnel may connect, start the system up and repair faults. These personnel must be thoroughly acquainted with all the warnings and operating procedures contained in this manual.
- Certain parameter settings may cause the inverter to restart automatically after an input power failure.
- This equipment is capable of providing internal motor overload protection in accordance with UL508C section 42. Refer to P074. Motor overload protection can also be provided by using an external PTC.
This equipment is suitable for use in a circuit capable of delivering not more than 100,000 symmetrical amperes (rms), for a maximum voltage of 230/460V* when protected by a time delay fuse*.
*As detailed in section 8.
- This equipment must **not** be used as an 'emergency stop' mechanism (see *EN 60204, 9.2.5.4*).



CAUTION

- Children and the general public must be prevented from accessing or approaching the equipment!
- This equipment must only be used for the purpose specified by the manufacturer. Unauthorised modifications and the use of spare parts and accessories that are not sold or recommended by the manufacturer of the equipment can cause fires, electric shocks and injuries.
- Keep these operating instructions within easy reach and give them to all users!



European Low Voltage Directive

The MICROMASTER Vector and MIDIMASTER Vector product range complies with the requirements of the Low Voltage Directive 73/23/EEC as amended by Directive 93/68/EEC. The units are certified for compliance with the following standards:

EN 60146-1-1	Semiconductor converters - General requirements and line commutated converters
EN 60204-1	Safety of machinery - Electrical equipment of machines

European Machinery Directive

The MICROMASTER Vector and MIDIMASTER Vector inverter series do not fall under the scope of the Machinery Directive. However, the products have been fully evaluated for compliance with the essential Health & Safety requirements of the directive when used in a typical machine application. A Declaration of Incorporation is available on request.

European EMC Directive

When installed according to the recommendations described in this manual, the MICROMASTER Vector and MIDIMASTER Vector fulfil all requirements of the EMC Directive as defined by the EMC Product Standard for Power Drive Systems EN61800-3.

Underwriters Laboratories



ISO 9001

Siemens plc operates a quality management system, which complies with the requirements of ISO 9001.

UL and CUL listed power conversion equipment 5B33 for use in a pollution degree 2 environment

IMPORTANT



WARNING

In order to ensure correct and safe operation, it is vital the following instructions are strictly adhered to:

- Operation of a motor with a higher nominal power than the inverter or a nominal power less than half that of the inverter is not allowed. The inverter must only be operated when the nominal current in P083 exactly matches the motor rating plate nominal current.
- The motor data parameters must be accurately entered (P080-P085) and an auto-calibration performed (P088=1) before the motor is started. Unstable/unpredictable motor operation (eg. reverse rotation) may result if this is not done. If this instability occurs, the mains supply to the converter must be disconnected.

When using the analogue input, the DIP switches must be correctly set and the analogue input type selected (P023) before enabling the analogue input with P006. If this is not done, the motor may start inadvertently.

1. OVERVIEW

The MICROMASTER Vector (MMV) and MIDIMASTER Vector (MDV) are a standard range of inverters with sensorless vector capability suitable for controlling the speed of 3 phase motors. Various models are available, ranging from the compact 120 W MICROMASTER Vector up to the 75 kW MIDIMASTER Vector.

Sensorless vector control allows the inverter to calculate the changes required in output current and frequency in order to maintain the desired motor speed across a wide range of load conditions.

For additional product information such as application examples, part numbers, operation with long cables etc, please refer to catalog DA64 or to <http://www.siemens.com/micromaster>

Features:

- Easy to install, program and commission.
- Overload capability 200% for 3s followed by 150% for 60s.
- High starting torque and accurate motor speed regulation by vector control.
- Optional integrated RFI filter on single-phase input inverters MMV12 - MMV 300, and three phase input inverters MMV220/3 to MMD750/3
- Fast Current Limit (FCL) for reliable trip-free operation.
- 0 to 50°C temperature range (0 to 40°C for MIDIMASTER Vector)
- Closed loop process control using a standard Proportional, Integral, Derivative (PID) control loop function. 15 V, 50 mA supply provided for feedback transducer.
- Remote control capability via RS485 serial link using the USS protocol with the ability to control up to 31 inverters via the USS protocol.
- Factory default parameter settings pre-programmed for European, Asian and North American requirements.
- Output frequency (and hence motor speed) can be controlled by:
 - (1) Frequency setpoint using the keypad.
 - (2) High resolution analogue setpoint (voltage or current input).
 - (3) External potentiometer to control motor speed.
 - (4) 8 fixed frequencies via binary inputs.
 - (5) Motorised potentiometer function.
 - (6) Serial interface.
- Built-in DC injection brake with special COMPOUND BRAKING.
- Built-in brake chopper for external resistor (MMV).
- Acceleration/deceleration times with programmable smoothing.
- Two fully-programmable relay outputs (13 functions).
- Fully-programmable analogue outputs (1 for MMV, 2 for MDV).
- External Options connector for optional multi-language Clear Text Display (OPM2), optional PROFIBUS-DP module or CANbus module
- Dual motor-parameter sets available if Clear Text Display (OPM2) fitted.
- Automatic recognition of 2,4,6 or 8-pole motors by software.
- Integral software controlled cooling fan.
- Side-by-side mounting without additional clearance.
- Optional protection to IP56 (NEMA 4/12) for MIDIMASTER Vector inverters.

1.1 Installation - General notes

Environmental Requirements

Hazard	Notes
Temperature	Min. Operating = 0°C Max. Operating = 50°C (MMV) Max. Operating = 40°C (MDV)
Altitude	If the Inverter is to be installed at an altitude >1000m, derating will be required.(Refer to DA64 Catalogue)
Shock	Do not drop the inverter or expose to sudden shock.
Vibration	Do not install the inverter in an area where it is likely to be exposed to constant vibration.
Electro-Magnetic Radiation	Do not install the inverter near sources of electro-magnetic radiation.
Atmospheric Pollution	Do not install the inverter in an environment, which contains atmospheric pollutants such as dust, corrosive gases, etc.
Water	Take care to site the inverter away from potential water hazards. e.g. Do not install the inverter beneath pipes that are subject to condensation. Avoid installing the inverter where excessive humidity and condensation may occur.
Overheating	Ensure that the inverter's air vents are not obstructed, including the air vent at the front of the unit, which should be at least 15mm from any obstruction. Additional ventilation may be required for horizontal mounting. Make sure that there is an adequate air-flow through the cabinet, as follows: 1. Using the formula below, calculate the air-flow required: $\text{Air-flow (m}^3 \text{ / hr)} = (\text{Dissipated Watts} / \Delta T) \times 3.1$ 2. If necessary, install cabinet cooling fan(s). Note: Dissipation (Watts) = 3-5% of inverter rating. ΔT = Allowable temperature rise within cabinet in °C. 3.1 = Specific heat of air at sea level.

Ideal Installation

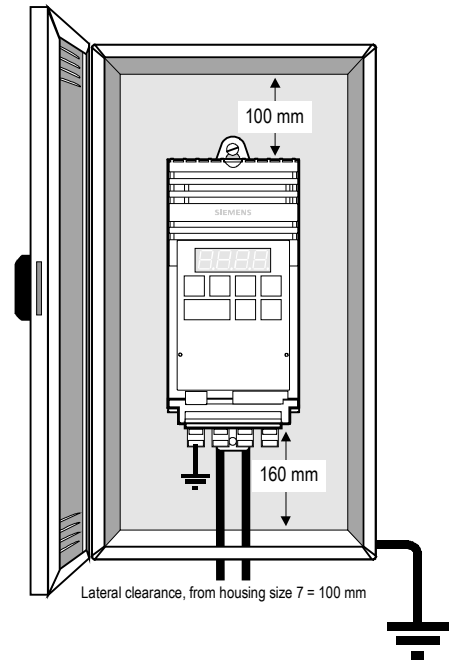

Figure: 1.1

Note: The Plastic Material of the case can be degraded by oil or grease. Care should be taken to ensure that the mounting surface and fixings are thoroughly degreased before use.

1.2 Wiring Guidelines to Minimise the Effects of EMI

The inverters are designed to operate in an industrial environment where a high level of Electro-Magnetic Interference (EMI) can be expected. Usually, good installation practices will ensure safe and trouble-free operation. If problems are encountered, the following guidelines may prove useful. In particular, grounding of the system at the inverter, as described below, may prove effective. Figures 1.2.1-1.2.3 illustrate how an RFI suppression filter should be installed and connected to the MICROMASTER Vector.

- (1) Ensure that all equipment in the cubicle is well earthed using short, thick earthing cable connected to a common star point or busbar. It is particularly important that any control equipment that is connected to the inverter (such as a PLC) is connected to the same earth or star point as the inverter via a short, thick link. Flat conductors (e.g. braids or metal brackets) are preferred as they have lower impedance at high frequencies.

The return earth from motors controlled by the inverter should be connected directly to the earth connection (PE) on the associated inverter.

- (2) On the MIDIMASTER Vector, use saw-tooth washers when mounting the inverter and ensure that a good electrical connection is made between the heatsink and the panel, removing paint if necessary.
- (3) Wherever possible, use screened leads for connections to the control circuitry. Terminate the ends of the cable neatly, ensuring that unscreened wires are as short as possible. Use cable glands whenever possible.
- (4) Separate the control cables from the power connections as much as possible, using separate trunking, etc. If control and power cables cross, arrange the cables so that they cross at 90° if possible.
- (5) Ensure that contactors in the cubicle are suppressed, either with R-C suppressors for AC contactors or 'flywheel' diodes for DC contactors, **fitted to the coils**. Varistor suppressors are also effective. This is particularly important if the contactors are controlled from the relay on the inverter.
- (6) Use screened or armoured cables for the motor connections and ground the screen at both ends via the cable glands.
- (7) If the drive is to be operated in an Electro-magnetic noise-sensitive environment, the RFI filter should be used to reduce the conducted and radiated interference from the inverter. For optimum performance, there should be a good conductive bond between filter and metal mounting plate.
- (8) For Frame Size A units (Fig.1.2.1), the flat earth braid strap, supplied with the unit, should be fitted to minimise emissions.

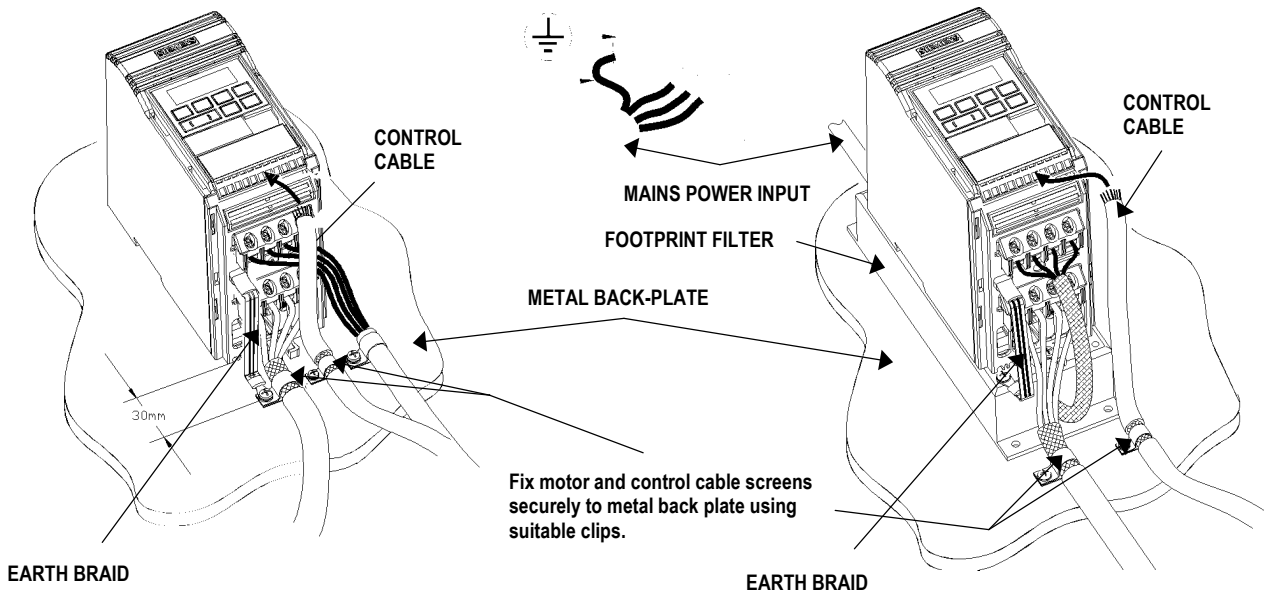

Figure 1.2.1: Wiring guidelines to minimise effects of EMI - MICROMASTER Vector Frame Size A

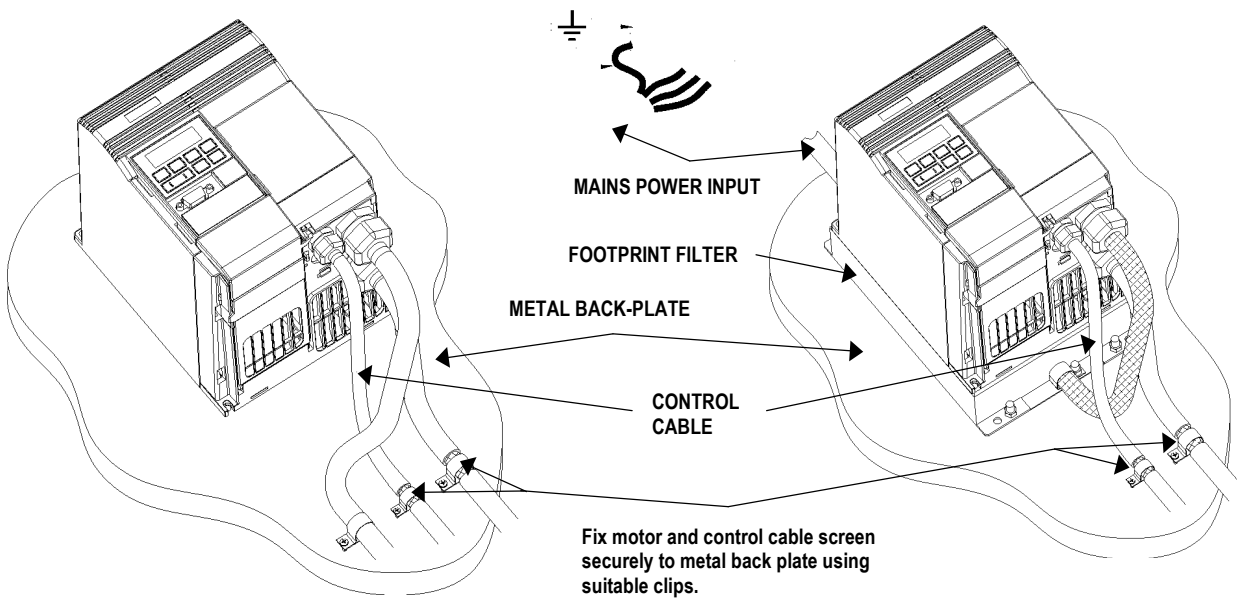

Figure 1.2.2: Wiring guidelines to minimise effects of EMI - MICROMASTER Vector Frame Size B

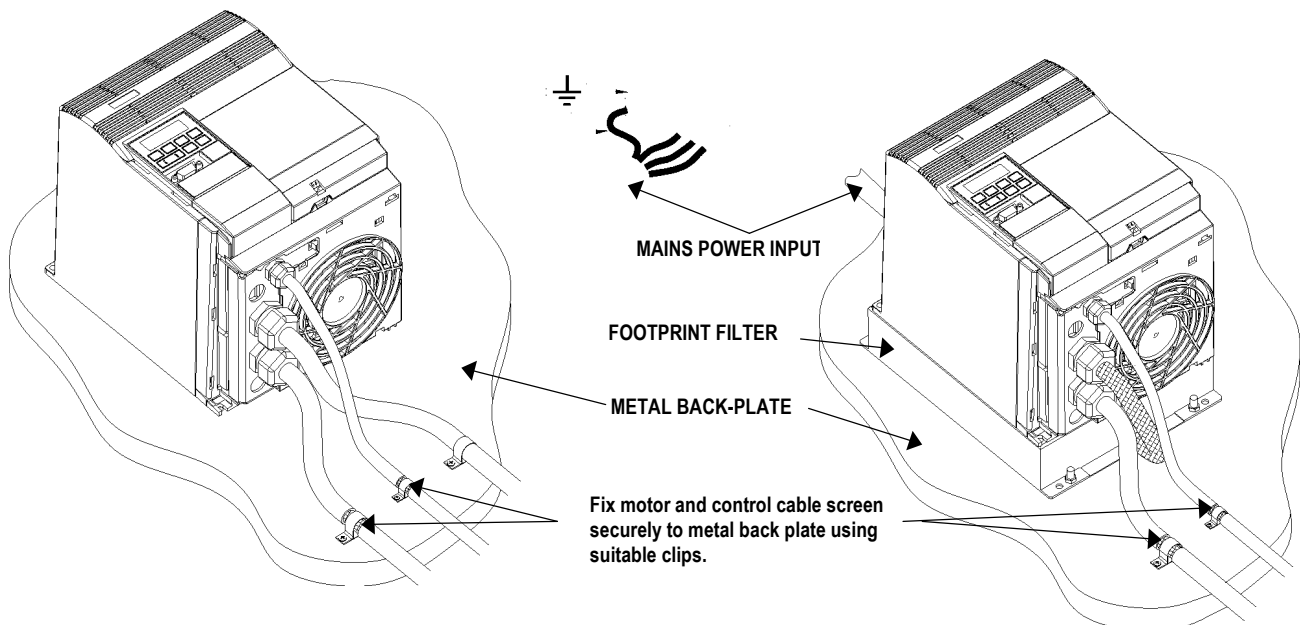

Figure 1.2.3: Wiring guidelines to minimise effects of EMI MICROMASTER Vector Frame Size C

On no account must safety regulations be compromised when installing inverters!

1.3 Electrical Installation - General Notes

1.3.1 Operation with Unearthed (IT) Supplies

MICROMASTER / MIDIMASTER Vector were developed for operation on grounded line supplies. These drive units can also be operated on non-grounded line supplies. However, we do not recommend this. However, if the drive units are operated on non-grounded line supplies, then the following points must be carefully observed:

- It is mandatory that line reactors are used.
- They are used to adapt line impedances and to minimize voltage peaks.
- It is also mandatory to use output reactors.
- The max. line supply voltage is 500V (the $\pm 10\%$ specified only refers to the range which is used to absorb voltage peaks)
- The drive unit is not shut down when ground faults occur on the incoming side.
- The drive unit is shutdown with fault F002 (overcurrent) if one or several output conductors develop a ground fault.
- Every drive unit has electronics which are grounded and which result in a $\sim 20\text{mA}$ ground fault current.
- The maximum clock cycle frequency is 2kHz.
- Only non-filtered drive units may be used.
- When operated at more than 40 Hz or briefly before full-load operation, the MIDIMASTER can be shut down with an overcurrent message.
- We recommend that ground fault monitoring devices are used at the incoming supply which can detect ground faults at the drive converter output
 - If necessary, an insulating transformer should be used

1.3.2 The use of residual-current protective devices

Drive inverters can be operated with residual-current protective devices under the following conditions:

- 1-phase:
Residual-current protective devices with 300mA (type A) are permissible
- 3-phase:
Universal residual-current protective device with 300mA (type B) must be used.
- Only one drive inverter may be connected to a residual-current protective device.
- The neutral conductor of the line supply must be grounded.
- The motor cables may not be longer than 50m when shielded or 100m when non-shielded
- The pulse frequency (P076) may not exceed max. 4kHz

1.3.3 Installation after a Period of Storage

It is necessary to reform the capacitors in the inverter if the unit has been stored for a prolonged period:

- Period of storage 1 year old or less:
No reforming is required.
- 1 - 2 years old:
Apply power to the inverter one hour before giving the run command (preparation time 1 hour).
- 2 - 3 years old:
Use a variable AC supply. Apply 25% of input voltage for 30 minutes. Increase volts to 50% for a further 30 minutes. Increase volts to 75% for further 30 minutes. Increase volts to 100% for a further 30 minutes. Now ready for run signal (preparation time 2 hours).
- 3 years and over:
As with 2 - 3 years, but the steps should be 2 hours (preparation time 8 hours).

1.3.4 Operation with Long Cables

Motor cable lengths vary depending on type of cable, power rating and voltage rating - and in some cases can be as long as 200m without the need for additional chokes. Refer to DA64 catalogue for further details.

In any case, all inverters will operate at full specification with cable lengths up to 25m for screened cable or 50m for unscreened cables.

2. INSTALLATION - MICROMASTER Vector

2.1 Mechanical Installation



WARNING

THIS EQUIPMENT MUST BE EARTHED.

To guarantee safe operation of the equipment it must be installed and commissioned properly by qualified personnel in compliance with the warnings laid down in these operating instructions.

Take particular note of general and regional installation safety regulations regarding work on dangerous voltage installations (e.g. VDE), as well as the relevant regulations regarding the correct use of tools and personal protective gear.

The mains input and motor terminals carry dangerous voltages even if the inverter is not operating. Use insulated screwdrivers on these terminal blocks.

MICROMASTER Vector inverters must be secured to a suitable vertical surface by bolts, washers and nuts. Frame size A units need two bolts or can be DIN rail mounted. Frame size B and C units require four bolts.

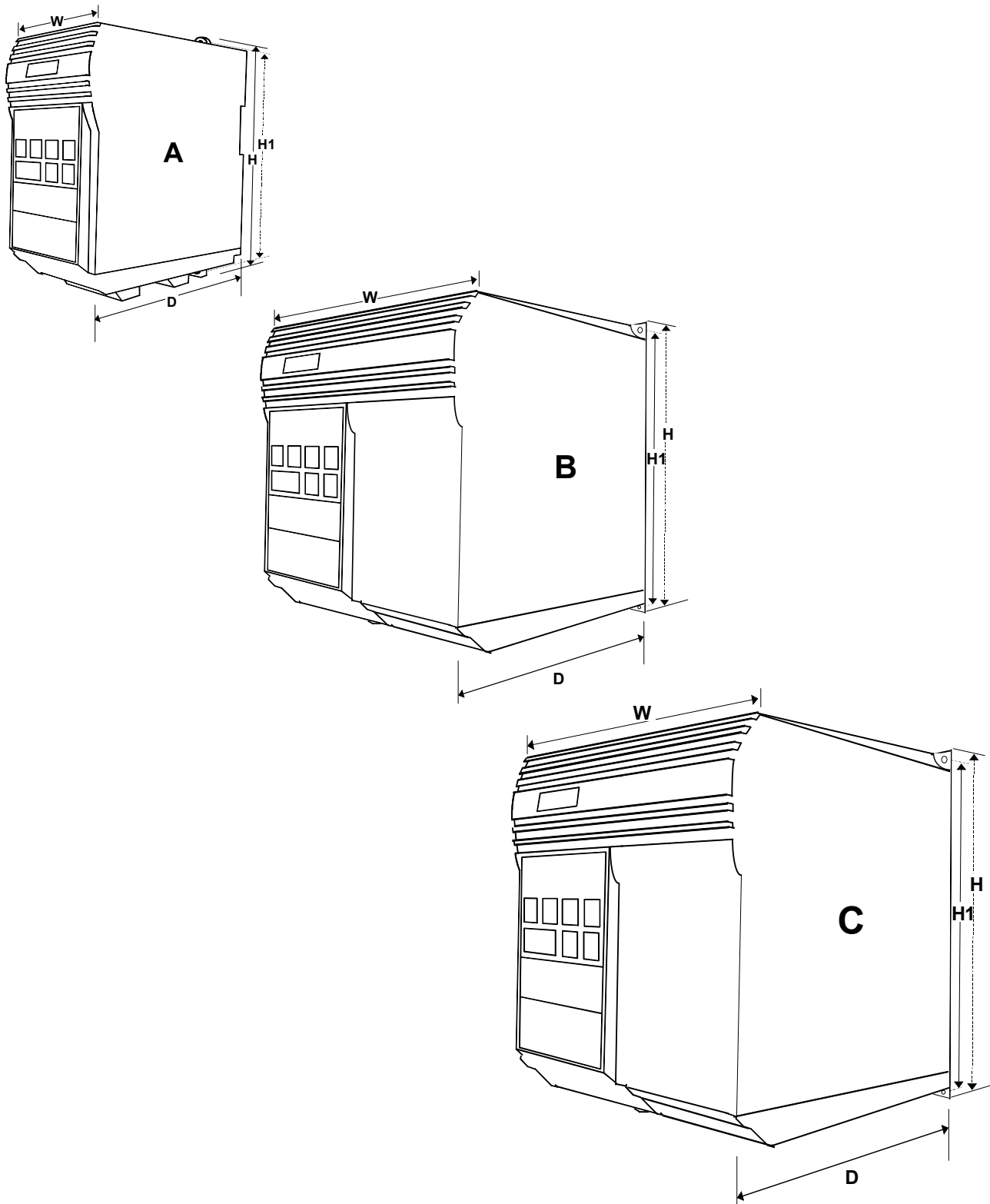
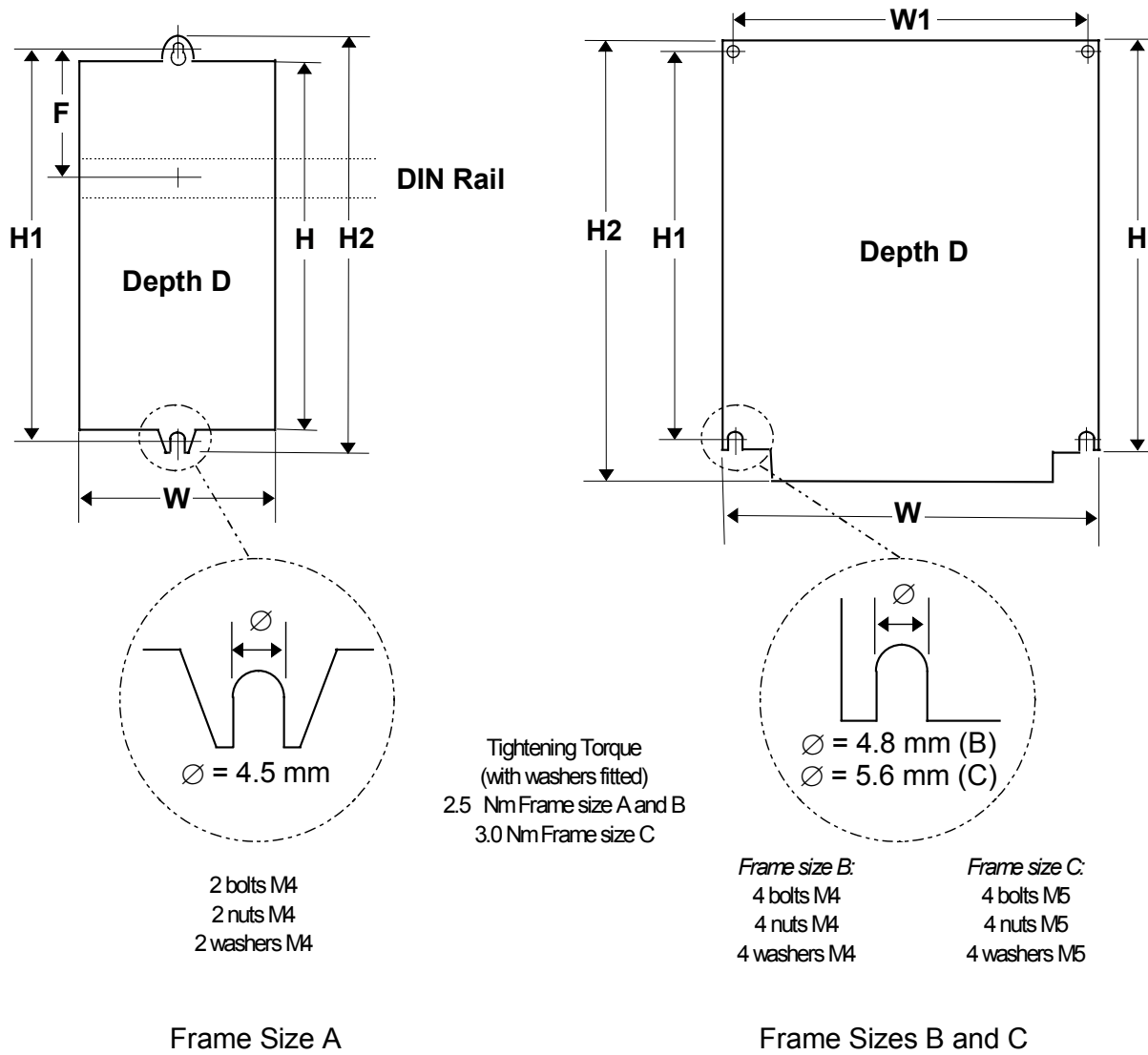

Figure 2.1.1: MICROMASTER Vector - Frame Size A, B and C



Model	MMVxxx	MMVxxx/2	MMVxxx/3	Frame Sizes (all measurements in mm)						
	1 AC 230V Class A Filter	1/3 AC 230V Without Filter	3 AC 380 - 500V Without Filter	H	W	D	H1	H2	W1	F
MMV12	A	A	-							
MMV25	A	A	-							
MMV37	A	A	A							
MMV55	A	A	A							
MMV75	A	A	A							
MMV110	B	B	A	A = 147	73	141	160	175	-	55
MMV150	B	B	A	B = 184	149	172	174	184	138	-
MMV220	C	C	B*	C = 215	185	195	204	232	174	-
MMV300	C	C	B*							
MMV400	-	C	C*							
MMV550	-	-	C*							
MMV750	-	-	C*							

* These units also available with built in filter e.g. MMV220/3F

Figure 2.1.2: Mechanical Installation Diagram - MICROMASTER Vector

2.2 Electrical Installation

Read the Wiring Guidelines given in section 1.2 before commencing installation.

The electrical connectors on the MICROMASTER Vector are shown in Figure 2.2.1.

Asynchronous and synchronous motors can be connected to the MICROMASTER Vector inverters either individually or in parallel.

Note: If a synchronous motor is connected to the inverter, the motor current may be two and a half to three times greater than that expected, so, the inverter must be de-rated accordingly. Also, the inverter cannot be used in vector mode when connected to a synchronous motor (P077= 0 or 2).

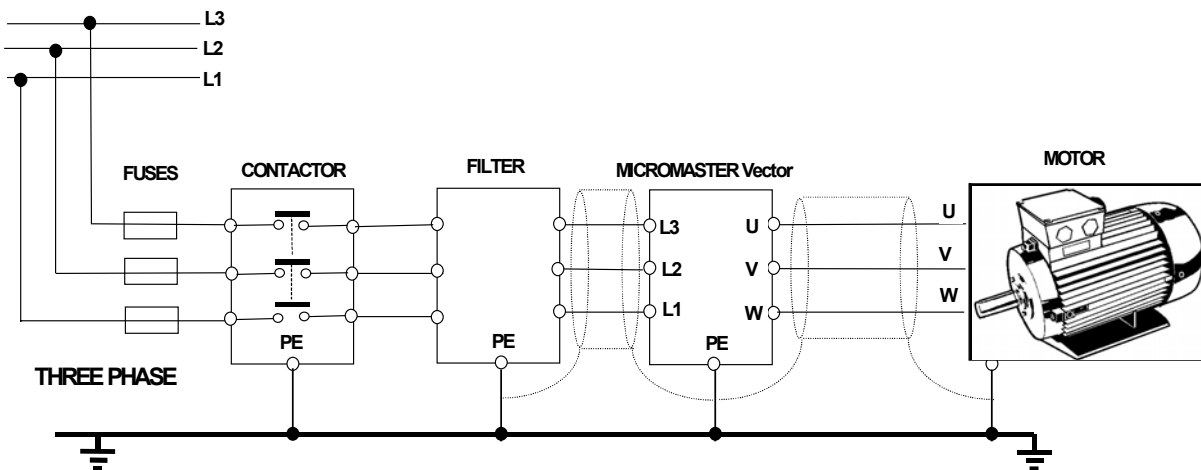
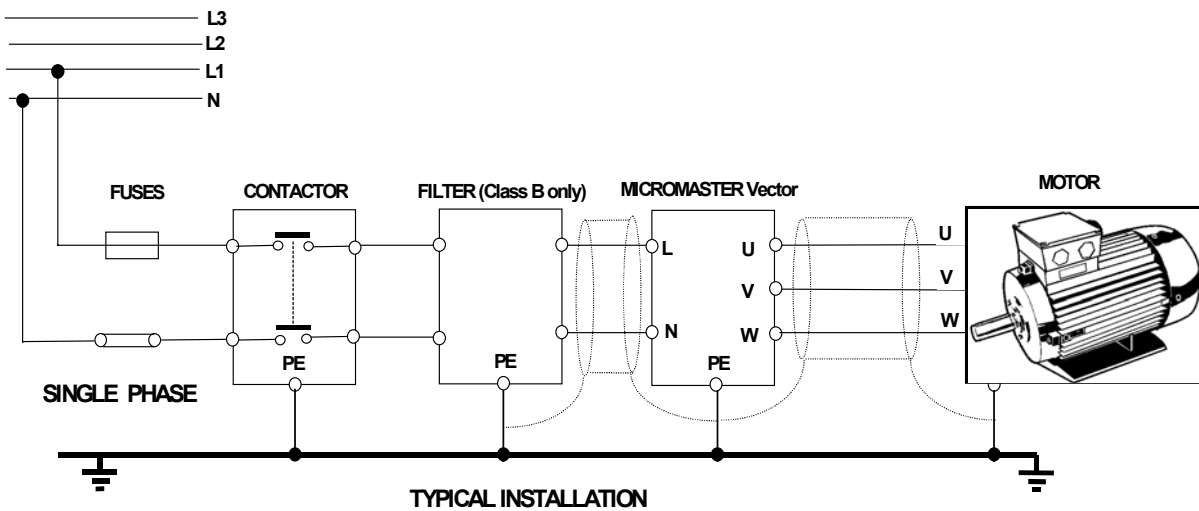
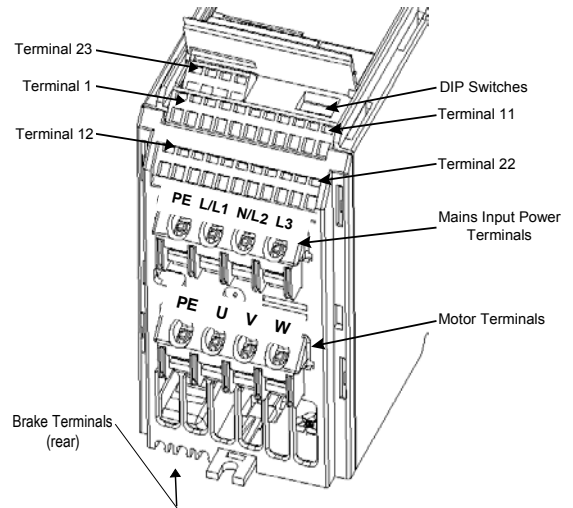

Figure 2.2.1: MICROMASTER Vector Connectors - Frame Size A



WARNING

Make sure that the input power supply is isolated before making or changing any connections to the unit.
 Ensure that the motor is configured for the correct supply voltage. Single/three phase 230 V units must not be connected to a 400 V three phase supply.
 When synchronous machines are connected or when coupling several motors in parallel, the inverter must be operated with voltage/frequency control characteristic (P077= 0 or 2) and slip compensation must be disabled (P071 = 0).
Note: This equipment is suitable for use in a circuit capable of delivering not more than 100,000 symmetrical amperes (rms), for a maximum voltage of 230 / 460 V * when protected by a time delay fuse *.
 * As detailed in section 8.

- *Frame size A:* the power terminals are directly available beneath the inverter. For the control terminals lift the flap in the front cover of the inverter. (As shown in Figure 2.2.1)
- *Frame size B:* use a small bladed screwdriver (as shown in Figure 2.2.2) to release the terminal cover of the inverter and allow it to swing down to hang beneath the inverter.
- *Frame size C:* use a small bladed screwdriver (as shown in Figure 2.2.3) to release the gland plate and the fan housing; allow them both to swing down to hang beneath the inverter.

Connect the cables to the power and control terminals in accordance with the information supplied in this section. Ensure that the leads are connected correctly and the equipment is properly earthed.



CAUTION

The control, power supply and motor leads must be laid separately. They must not be fed through the same cable conduit/trunking.
 High voltage insulation test equipment must not be used on cables connected to the inverter.

Use screened cable for the control cable, Class 1 60/75°C copper wire only. Tightening torque for the field wiring terminals is 1.1 Nm.

A small bladed screwdriver, max. 3.5 mm will be required to operate the control terminal WAGO cable clamp connectors as shown in Figure 2.2.4.

To tighten up the power and motor terminal screws use a 4 - 5 mm cross-tip screwdriver.

When all power and control connections are complete:

- *Frame size A:* lower the flap in the front cover of the inverter.
- *Frame size B:* lift and secure the terminal cover to the inverter.
- *Frame size C:* lift and secure the gland plate and the fan housing to the inverter.

2.2.1 Power and Motor Connections - MICROMASTER Vector - Frame Size A

1. Ensure that the power source supplies the correct voltage and is designed for the necessary current (see section 8). Ensure that the appropriate circuit breakers with the specified current rating are connected between the power supply and inverter (see section 8).

2. Fit the earth braid strap, supplied with the unit, between the PE faston connector and the mounting surface. Ensure there is a good electrical connection between the mounting surface and the earth strap.
3. Connect the power input directly to the power terminals L/L1 - N/L2 (1 phase) or L/L1, N/L2, L3 (3 phase), and earth (PE) as shown in Figure 2.2.1, using a 3-core cable for single phase units or a 4-core cable for three phase units. For the cross-section of each core see section 8.
4. Use a 4-core screened cable to connect the motor. The cable is connected to the motor terminals U, V, W and the earth (PE) shown in Figure 2.2.1.

Note: For operation with cables longer than 25m see section 1.3.4

5. If required, secure Faston connectors to the braking resistor leads and fit the connectors to the B+/DC+ and B- terminals at the rear of the inverter.

Note: These connections have to be made with the inverter dismounted from the mounting surface. Care must be taken routing the leads through the moulded clips to prevent trapping and chafing when the unit is mounted and secured to the selected surface. Connect the control leads as shown in Figures 2.2.4 and 2.2.6.

2.2.2 Power and Motor Connections - MICROMASTER Vector - Frame Size B

The terminal arrangement for frame size B is similar to frame size A
 Refer to Figures 2.2.1 and 2.2.2 and proceed as follows:

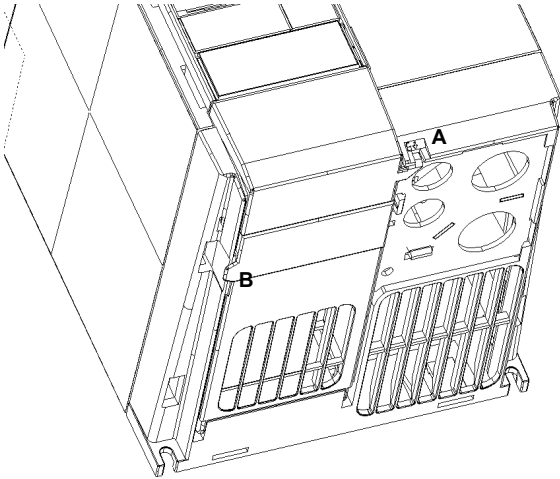

1. Insert the blade of a small screwdriver into slot A in the front of the inverter and press in the direction of the arrow. At the same time, press down on tab B at the side of the access panel.

Power Connections Access Diagram - Frame Size B

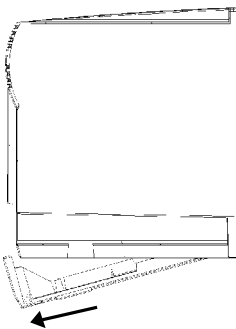

2. This will release the access panel, which will then swing down on its rear-mounted hinges.
Note: The access panel can be removed from the inverter when at an angle of approximately 30° to the horizontal. If allowed to swing lower, the panel will remain attached to the inverter.

Removal of Terminal Cover- Frame Size B

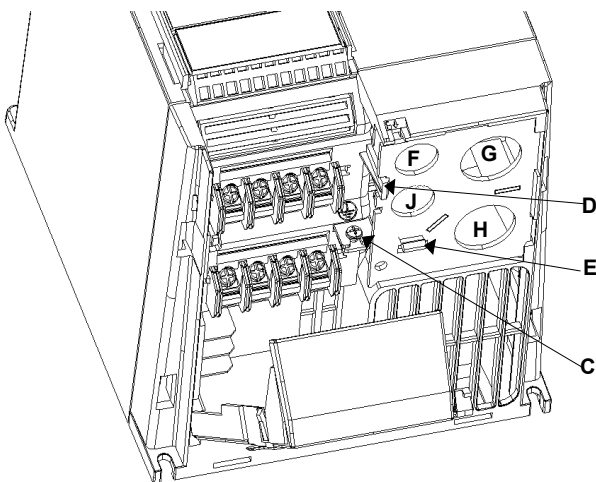

3. Remove the earthing screw C from the gland plate.
4. Press both release catches D and E to release the gland plate and then remove the metal gland plate from the inverter.

- F: Control cable input
- G: Mains cable input
- H: Motor cable output
- J: Braking resistor/ DC link cable input

Figure 2.2.2 : Power and Motor Connectors MICROMASTER Vector Frame Size B

5. Ensure that the power source supplies the correct voltage and is designed for the necessary current. Ensure that the appropriate circuit-breakers with the specified current rating are connected between the power supply and inverter see section 8.
6. For the power input, use a 3-core cable for single phase units or a 4-core cable for three phase units. For the cross-section of each core see section 8.
7. Use a 4-core screened cable to connect the motor.
8. Carefully measure and cut the cable leads for power connections, motor connections and braking resistor connections (if required) before feeding the screened cables through the glands in the metal gland plate provided (see Figure 2.2.2) and securing the glands.
9. Carefully measure and cut the cable leads for the control connections (if required). Feed the control cable through the correct gland (see Figure 2.2.2) and secure the gland to the metal gland-plate.
10. Carefully feed the power and control leads through the correct holes in the inverter housing.
11. Secure the metal gland plate to the underside of the inverter. Fit and tighten the earth securing screw.
12. Connect the power input leads to the power terminals L/L1 - N/L2 (1 phase) or L/L1, N/L2, L3 (3 phase), and earth (PE) shown in Figure 2.2.1 and torque down the screws.
13. Connect the motor leads to the motor terminals U, V, W and the earth (PE) (*shown in Figure 2.2.1*) and torque down the screws.
Note: For operation with cables longer than 25m see section 1.3.4
14. If required, secure Faston connectors to the braking resistor leads and fit the connectors to the B+/DC+ and B- terminals under the inverter.
15. Connect the control leads as shown in Figures 2.2.4 and 2.2.6.

2.2.3 Power and Motor Connections - MICROMASTER Vector - Frame Size C

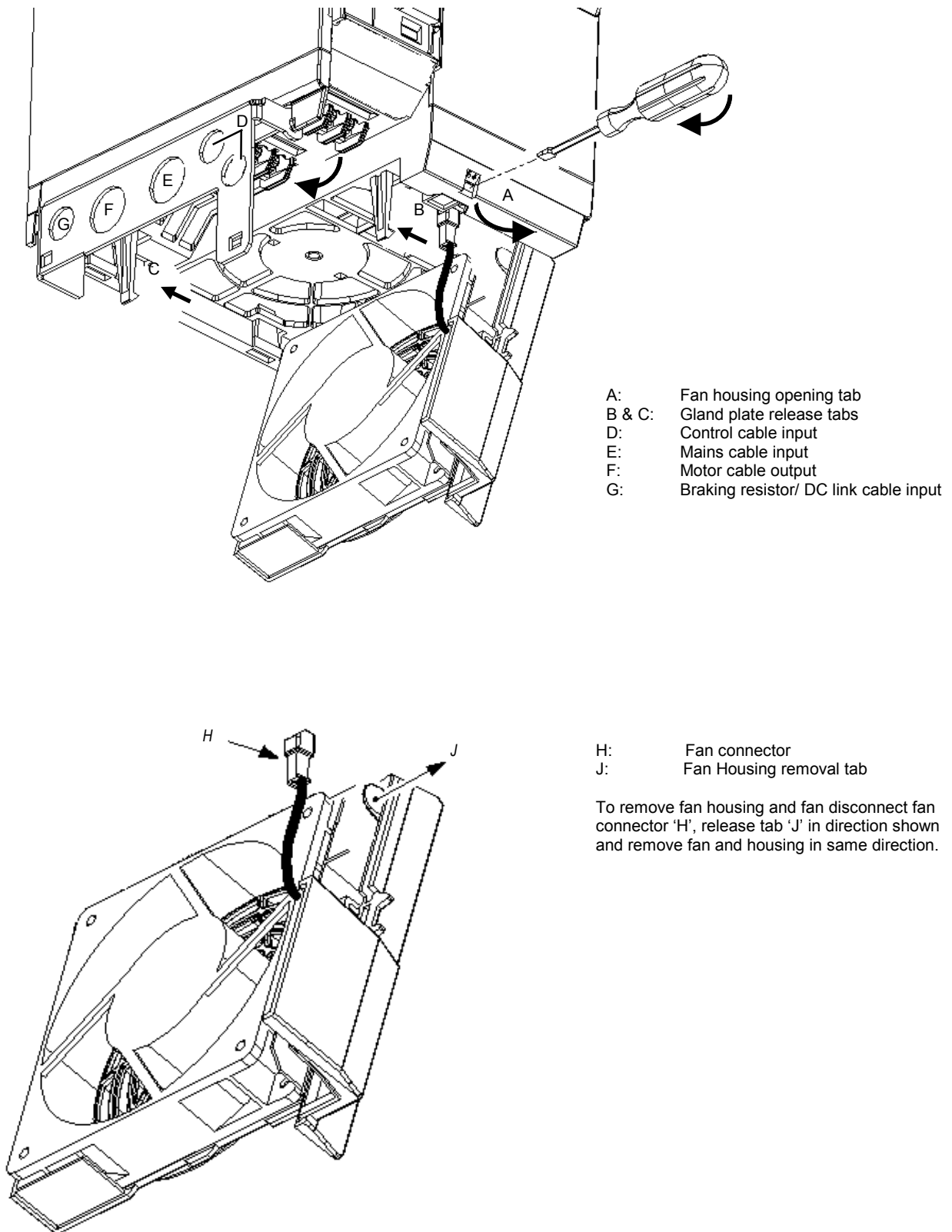

Figure 2.2.3: Power Connections Access Diagram - Frame Size C

The terminal arrangement for frame size C is similar to frame size A.

Refer to Figures 2.2.1 and 2.2.3 and proceed as follows:

1. While supporting the fan housing with one hand, insert the blade of a screwdriver into slot A on the underside of the inverter and press upwards to release the securing tab. Lower the fan housing, allowing it to swing out to the right on its side-mounted hinges.
2. Applying pressure to the gland plate release clips B and C in the direction of the arrows. Swing the plate out to the left on its side-mounted hinges.
3. Ensure that the power source supplies the correct voltage and is designed for the necessary current (*see section 8*). Ensure that the appropriate circuit-breakers with the specified current rating are connected between the power supply and inverter (*see section 8*).
4. For the power input, use a 3-core cable for single phase units or a 4-core cable for three phase units. For the cross-section of each core see section 8.
5. Use a 4-core screened cable to connect the motor.
6. Carefully measure and cut the cable leads for power connections, motor connections and braking resistor connections (if required) before feeding the screened cables through the glands in the metal gland plate and securing the glands.
7. Carefully measure and cut the cable leads for the control connections (if required). Feed the control cable through the correct gland and secure the gland to the metal gland-plate.
8. Connect the power input leads to the power terminals L/L1 - N/L2 (1 phase) or L/L1, N/L2, L3 (3 phase), and earth (PE) (*shown in Figure 2.2.1*) and torque down the screws.
9. Connect the motor leads to the motor terminals U, V, W and the earth (PE) (*shown in Figure 2.2.1*) and torque down the screws.
Note: For operation with cables longer than 25m see section 1.3.4
10. If required, secure Faston connectors to the braking resistor leads and fit the connectors to the B+/DC+ and B- terminals under the inverter.
11. Connect the control leads as shown in Figures 2.2.4 and 2.2.6

2.2.4 Control Connections

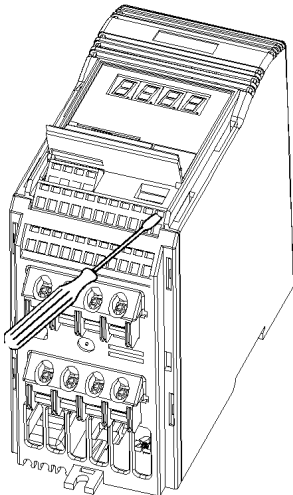

Insert small blade screwdriver (max. 3.5 mm) as shown, while inserting control wire from below. Withdraw the screwdriver to secure the wire.

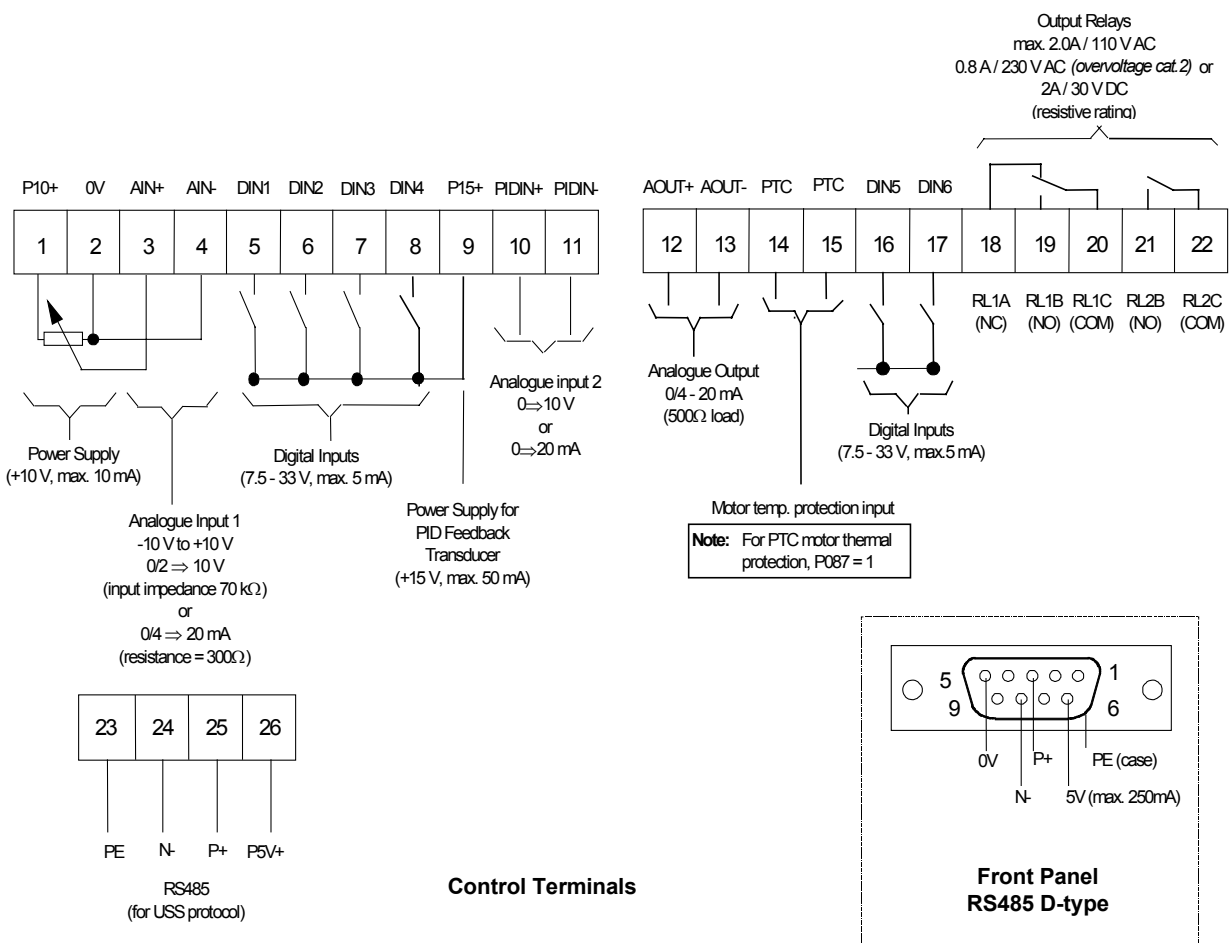

Figure 2.2.4: Control Connections - MICROMASTER Vector

Note: Do not use the internal RS485 connections (terminals 24 and 25) if you intend using the external RS485 connection on the front panel e.g. to connect a Clear Text Display (OPM2).

DIP switches select between voltage (V) and current (I) analogue inputs and also select either a voltage or current feedback signal (see Figure 4.1.2: DIP Selector Switches). These switches can only be accessed when the flap in the the front cover is raised (see Figure 2.2.1).

2.2.5 External Motor Thermal Overload Protection

When operated below rated speed, the cooling effect of fans fitted to the motor shaft is reduced. so that most motors require de-rating for continuous operation at low frequencies. To ensure that motors are protected against overheating under these conditions it is strongly recommended that a PTC temperature sensor is fitted to the motor and connected to the inverter control terminals as shown in Figure 2.2.5.

Note: To enable the motor overload protection trip function, set parameter P087=1

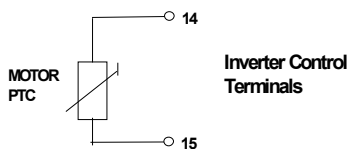

Figure 2.2.5: Motor Overload PTC Connection.

2.2.6 Block Diagram - MICROMASTER Vector

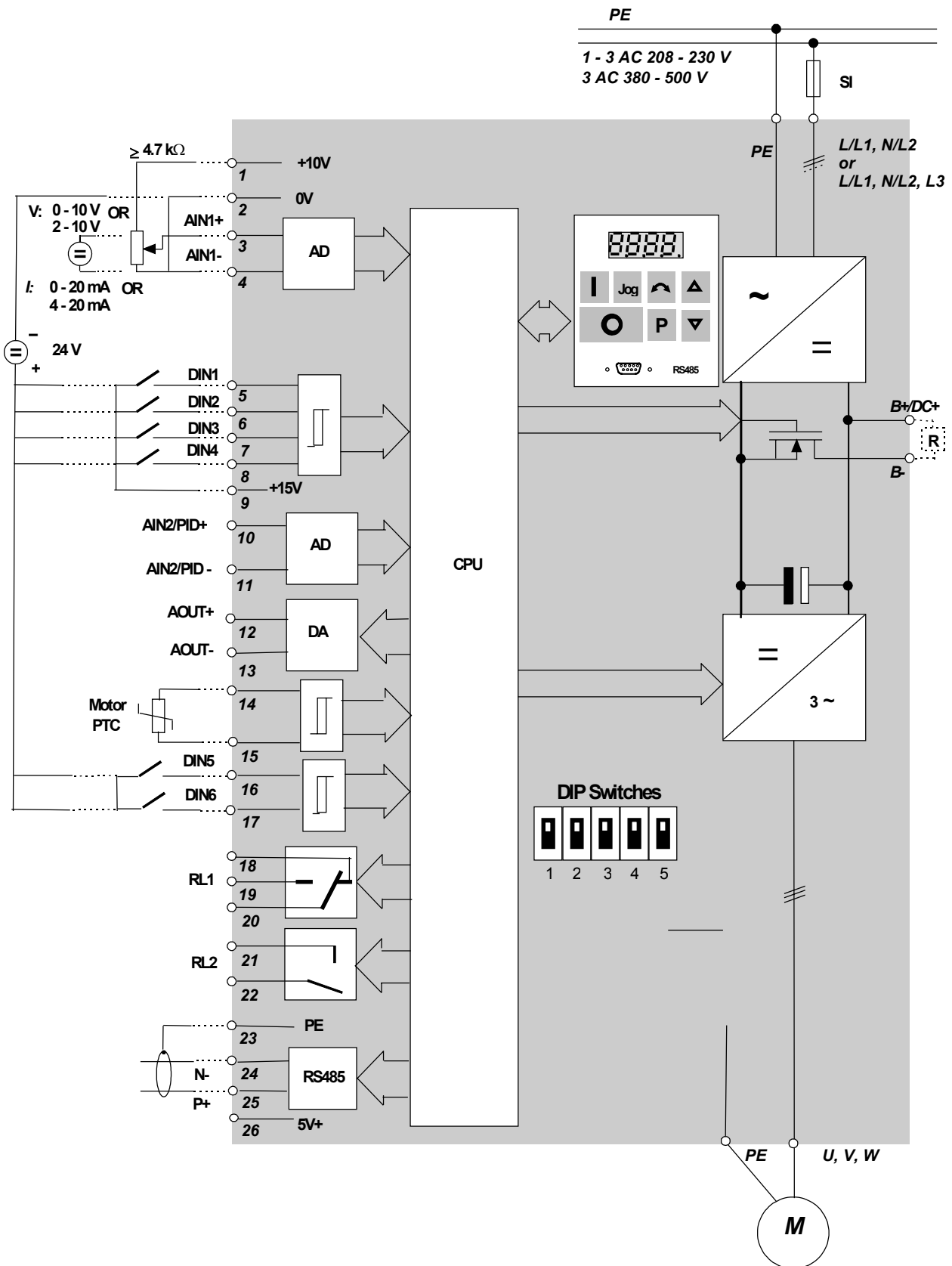



Figure 2.2.6 Block Diagram - MICROMASTER Vector

3. INSTALLATION - MIDIMASTER Vector

3.1 Mechanical Installation

 	<p>WARNING</p> <p>THIS EQUIPMENT MUST BE EARTHED.</p> <p>This equipment must not be energised with the cover removed.</p> <p>To guarantee the safe operation of the equipment it must be installed and commissioned properly by qualified personnel in compliance with the warnings laid down in these operating instructions.</p> <p>Take particular note of the general and regional installation and safety regulations regarding work on high voltage installations (e.g. VDE), as well as the relevant regulations regarding the correct use of tools and personal protective gear.</p> <p>Mount the inverter vertically to a flat, non combustible surface. Make sure that the unobstructed clearance for each of the cooling inlets and outlets above and below the inverter is at least 100 mm.</p>
--	---

Environmental requirements are described in section 1.1

The MIDIMASTER Vector must be secured to a suitable load-bearing wall by M8 bolts, washers and nuts. Frame size 4, 5 and 6 units need four bolts. Frame size 7 units should be lifted using the two lifting holes and secured by six bolts.

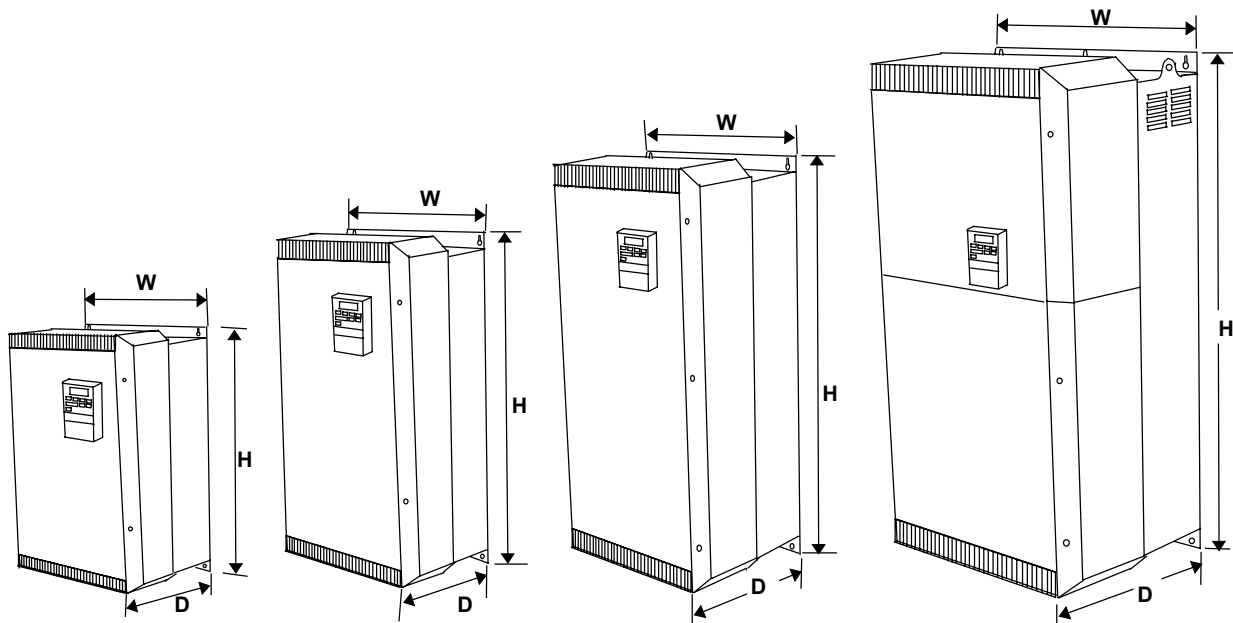

Figure 3.1.1: MIDIMASTER Vector - Frame Size 4, 5, 6 and 7

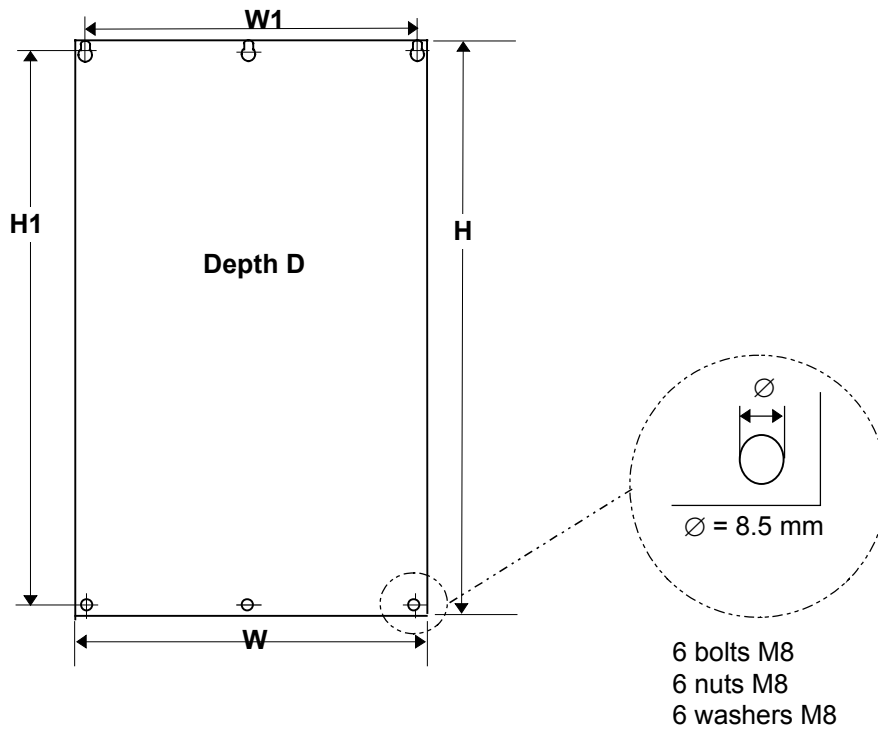
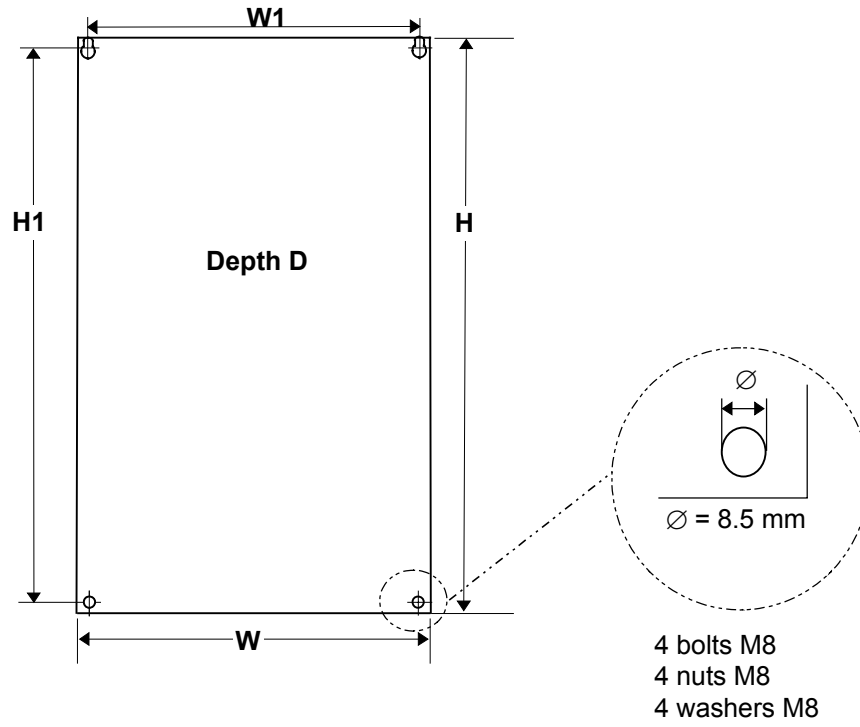

Figure 3.1.2: Mechanical Installation Diagram - MIDIMASTER Vector

Model	3 AC 208 - 240 V	3AC 380 -500 V	3 AC 525 - 575 V	Frame Sizes (mm)					Notes
				W	H	D	W1	H1	
MDV220/4	-	-	4						
MDV400/4	-	-	4	IP21 / NEMA 1					
MDV550/2	4	-	-						Note: Dimension D includes the front control panel.
MDV550/4	-	-	4	4 =	275 x 450	x 210	235	430	
MDV750/2	4	-	-						If a Clear Text Display (OPM2) is to be included, an additional 30mm will be required.
MDV750/3	-	4	-	5 =	275 x 550	x 210	235	530	
MDV750/4	-	-	4						Filtered MIDIMASTER Vector versions are available up to 460V mains supply only.
MDV1100/2	5	-	-	6 =	275 x 650	x 285	235	630	
MDV1100/3	-	4	-						IP20/NEMA 1 with integrated EMC class A filter
MDV1100/4	-	-	4						
MDV1500/2	6	-	-						
MDV1500/3	-	5	-						
MDV1500/4	-	-	5						
MDV1850/2	6	-	-	4 =	275 x 700	x 210	235	680	
MDV1850/3	-	5	-						
MDV1850/4	-	-	5	5 =	275 x 800	x 210	235	780	
MDV2200/2	6	-	-						
MDV2200/3	-	6	-	6 =	275 x 920	x 285	235	900	
MDV2200/4	-	-	6						
MDV3000/2	7	-	-	7 =	420 x 1150	x 310	374	1130	
MDV3000/3	-	6	-						
MDV3000/4	-	-	6						
MDV3700/2	7	-	-						IP56 / NEMA 4/12
MDV3700/3	-	6	-						
MDV3700/4	-	-	6						
MDV4500/2	7	-	-	4 =	360 x 675	x 376	313	649	
MDV4500/3	-	7	-						Note: Dimension D includes the front panel access door.
MDV4500/4	-	-	6	5 =	360 x 775	x 445	313	749	
MDV5500/3	-	7	-						
MDV7500/3	-	7	-	6 =	360 x 875	x 505	313	849	
				7 =	500 x 1150	x 595	451	1122	

Figure: 3.1.2 (continued)

3.2 Electrical Installation

Read the Wiring Guidelines given in section 1.2 before commencing installation.
The electrical connectors on the MIDIMASTER Vector are shown in Figure 3.2.1.

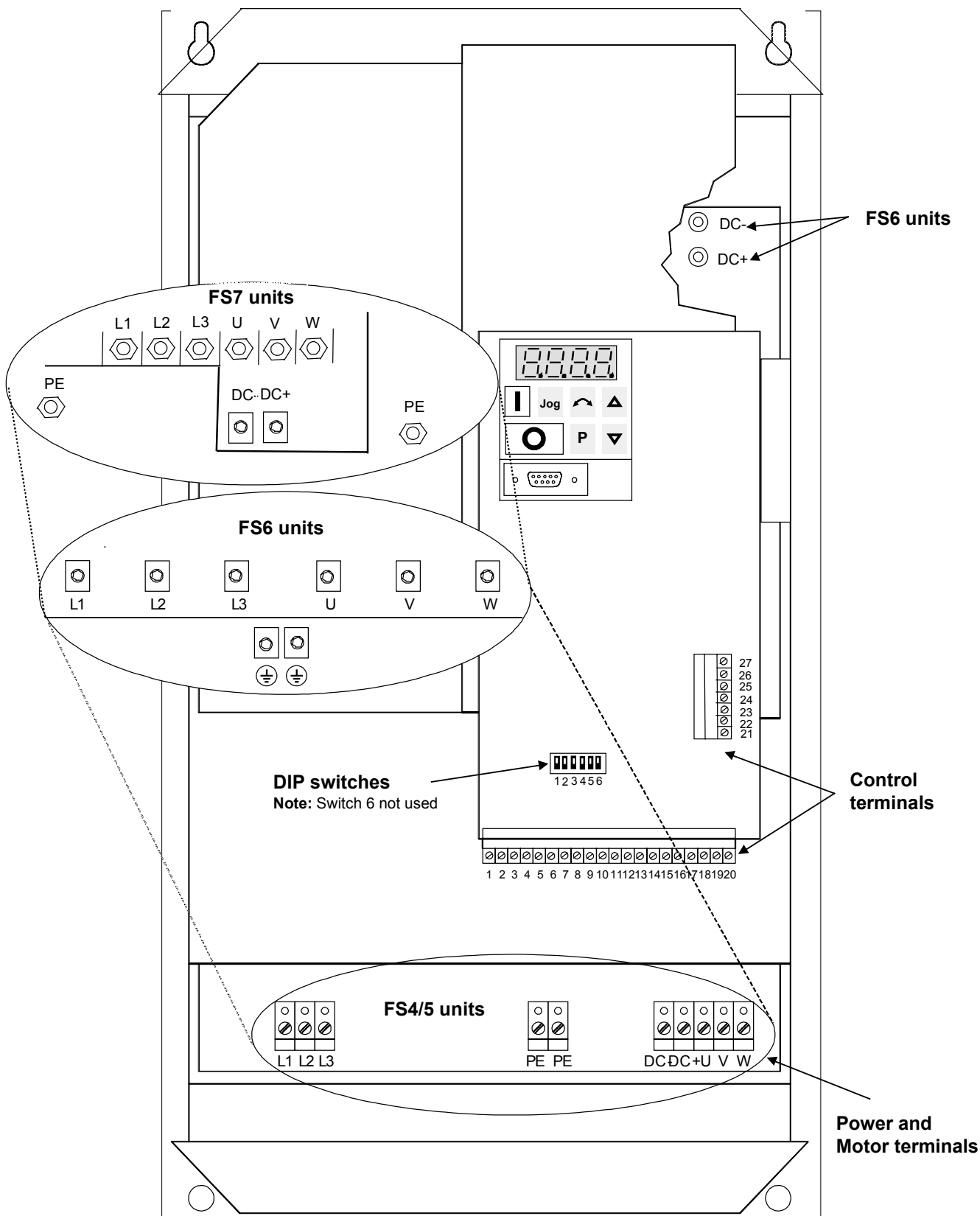

Figure 3.2.1: MIDIMASTER Vector Connectors

To gain access to the power and control terminals:

- *Frame size 4, 5* : remove the four M4 screws from the front cover and remove the cover from the inverter.
- *Frame size 6*: remove the six M4 screws from the front cover and remove the cover from the inverter.
- *Frame size 7*: remove the four M4 screws from the lower front cover and remove the lower front cover from the inverter.



WARNING

Ensure that the motor is configured for the correct supply voltage.

Make sure that the input power supply is isolated before making or changing any connections.

When synchronous machines are connected or when coupling several motors in parallel, the inverter must be operated with voltage/frequency control characteristic (P077= 0 or 2) and slip compensation must be disabled (P071 = 0).



CAUTION

The control, power supply and motor leads **must** be laid separately. They must **not** be fed through the same cable conduit/trunking.

High voltage insulation test equipment must **not** be used on cables connected to the inverter.

Use screened cable for the control cable, Class 1 60/75°C copper wire only.

Feed the cables through the correct glands in the base of the inverter. Secure the cable glands to the inverter and connect the leads to the power, motor and control terminals in accordance with the information supplied in sections 3.2.1 and 3.2.2. Ensure that the leads are connected correctly and the equipment is properly earthed.

Frame size 4 and 5: Tighten up each of the power and motor terminal screws to 1.1 Nm.

Frame size 6: Tighten up each of the power and motor terminal Allen-screws to 3.0 Nm.

Frame size 7: Tighten up each of the M12 power and motor terminal nuts to 30 Nm.

Secure the front cover to the inverter when all connections are complete.

3.2.1 Power and Motor Connections

1. Ensure that the power source supplies the correct voltage and the necessary current. Ensure that the appropriate circuit-breaker or fuses with the specified current rating are connected between the power supply and inverter (*see section 8*).
2. Connect the power input to the power terminals L1, L2, L3 (3 phase) and earth (PE) (*shown in Figure 3.2.1*) using a 4-core cable and lugs to suit the cable size. For the cross-section of each core, see section 8.
3. Use a 4-core screened cable and suitable lugs to connect the motor leads to the motor terminals U, V, W and earth (PE) (*shown in Figure 3.2.1*).

Note: For operation with cables longer than 25m see section 1.3.4

4. If required, connect the braking unit leads to the DC- and DC+ terminals.
5. Tighten all the power and motor terminals.

Asynchronous and synchronous motors can be connected to the MIDIMASTER Vector inverters either individually or in parallel.

Note : If a synchronous motor is connected to the inverter, the motor current may be two and a half to three times greater than that expected so the inverter must be de-rated accordingly.

3.2.2 Control Connections

Control connections to the MIDIMASTER Vector are made via two terminal blocks located as shown in Figure 3.2.1. The terminal blocks are of a two-part design. The part containing the screw terminals can be unplugged from it's housing before wires are connected. When all connections to the terminals have been made (as shown in Figures 3.2.1 and 3.2.2) and secured, the terminal block must be plugged firmly back into it's housing.

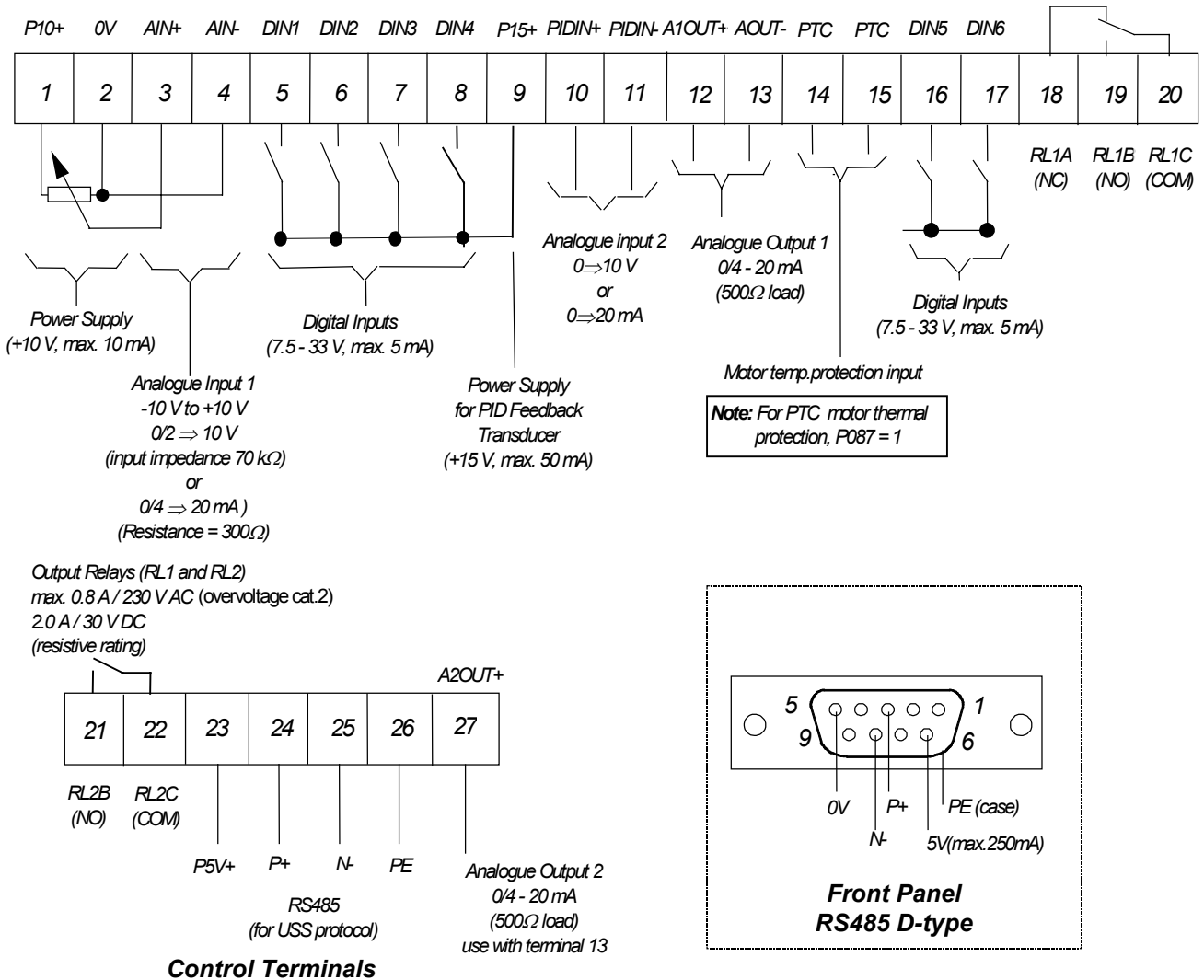

Figure 3.2.2: Control Connections - MIDIMASTER Vector

Note: Do not use the internal RS485 connections (terminals 24 and 25) if you intend using the external RS485 connection on the front panel e.g. to connect an Clear Text Display (OPM2).

DIP switches select between voltage (V) and current (I) analogue inputs. They also select between either a voltage or current PID feedback signal (see Figure 4.1.2: DIP Selector Switches). These switches can only be accessed when:

- for Frame size 4, 5 and 6 the front cover is removed (see Figure 3.2.1).
- for Frame size 7 the lower front cover is removed (see Figure 3.2.1).

3.2.3 Motor Overload Protection

When operated below rated speed, the cooling effect of fans fitted to the motor shaft is reduced. so that most motors require de-rating for continuous operation at low frequencies. For protection measures using a PTC see section 2.2.5.

3.2.4 Block Diagram – MIDIMASTER Vector

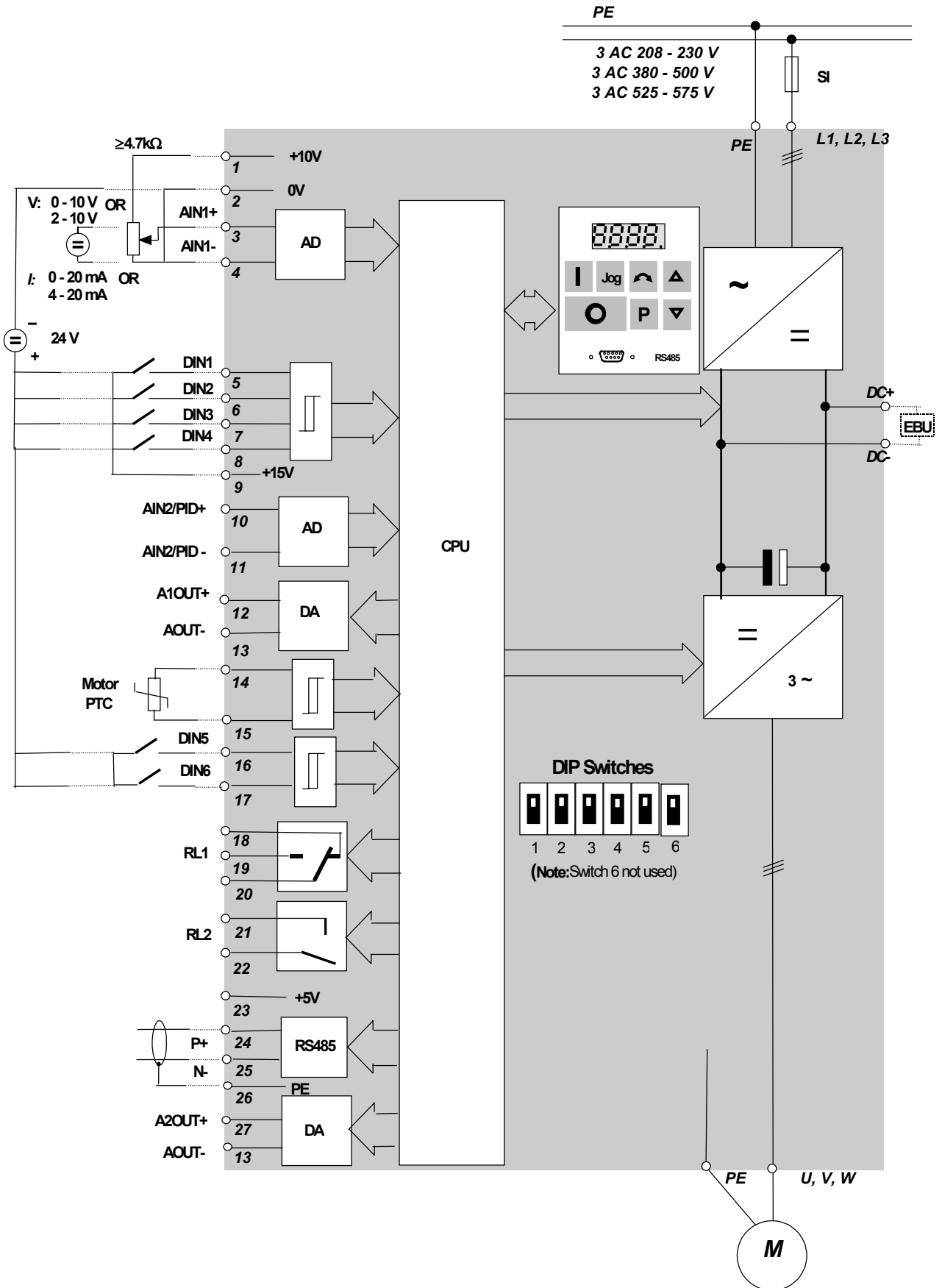

4. CONTROLS & BASIC OPERATION

4.1 Controls



CAUTION

The digital frequency setpoint has been set at 5.00 Hz in the factory. It is not necessary to enter a frequency setpoint via the Δ button or parameter P005 in order to test that the motor turns following a RUN command.

All settings must be entered by qualified personnel, paying particular attention to the safety precautions and warnings.

The parameter settings required can be entered using the three parameterisation buttons (P, Δ and ∇) on the front panel of the inverter. The parameter numbers and values are indicated on the four digit LED display.

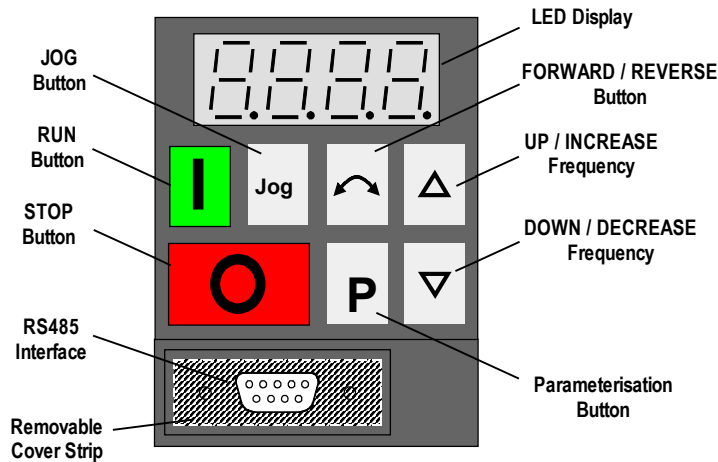









	Pressing this button while the inverter is stopped causes it to start and run at the preset jog frequency. The inverter stops as soon as the button is released. Pressing this button while the inverter is running has no effect. Disabled if P123 = 0.
	Press to start the inverter. Disabled if P121 = 0.
	Press to stop the inverter. Press once for an OFF1 (see section 5.4). Press twice (or hold down) for an OFF2 (see section 5.4) to immediately remove voltage from the motor allowing the motor to coast to a halt without ramp-down.
	Displays frequency (default), parameter numbers or parameter values (when P is pressed) or fault codes.
	Press to change the direction of rotation of the motor. REVERSE is indicated by a minus sign (values <100) or the left decimal point flashing(values > 100). Disabled if P122 = 0
	Press to INCREASE frequency. Used to change parameter numbers or values to higher settings during the parameterisation procedure. Disabled if P124 = 0.
	Press to DECREASE frequency. Used to change parameter numbers or values to lower settings during the parameterisation procedure. Disabled if P124 = 0.
	Press to access parameters. Disabled if P051 - P055 or P356 = 14 when using digital inputs. Press and hold to access higher resolution for some parameters. See section 6

Figure 4.1.1: Front Panel

4.1.2 DIP Selector Switches

The five DIP selector switches have to be set in agreement with P023 or P323 according to the operation of the inverter. Figure 4.1.2 below, shows the settings of the switches for the different modes of operation.

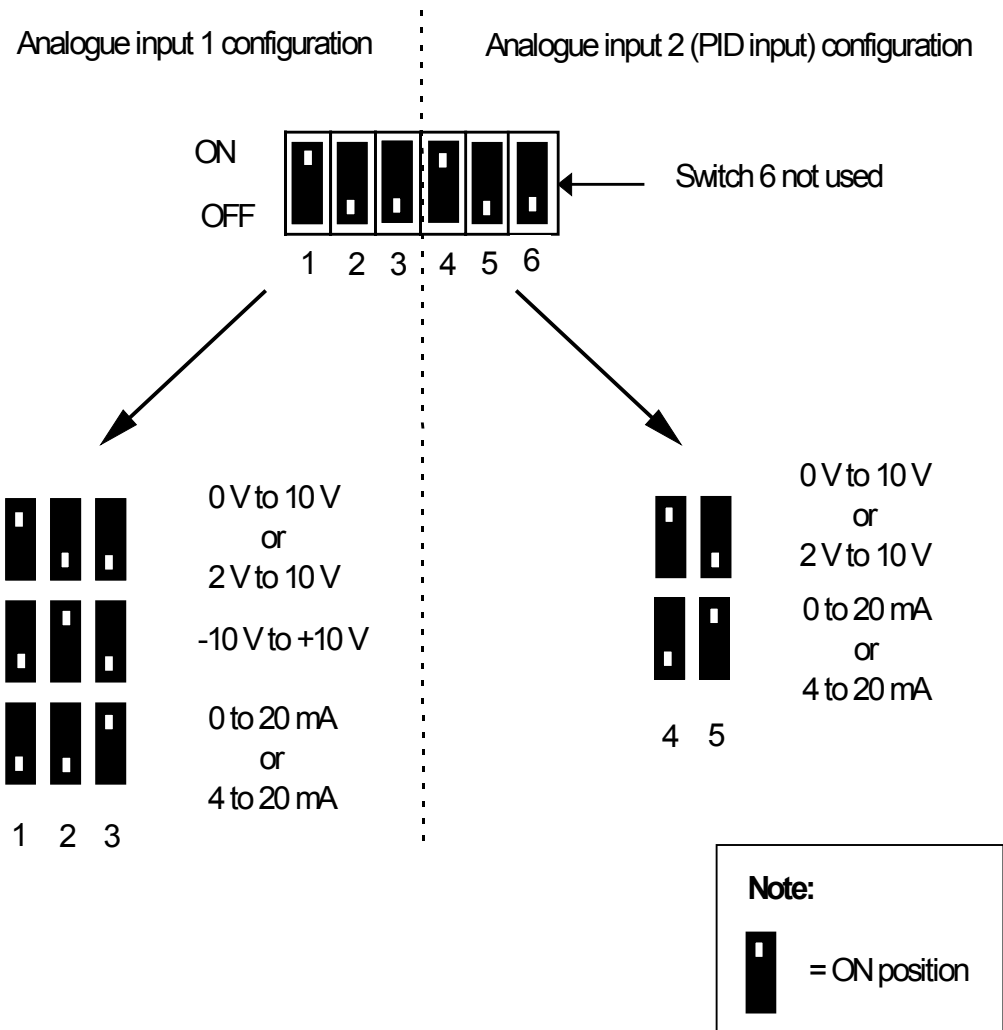

Figure 4.1.2. DIP Selector Switches

4.2 Basic Operation

Refer to section 6 for a full description of each parameter.

4.2.1 General

- (1) The inverter does not have a main power switch and is therefore live when the mains supply is connected. It waits with the output disabled until the RUN button is pressed or for the presence of a digital ON signal via terminal 5 (rotate right- default) or terminal 6 (rotate left- default) - see parameters P051 to P055 and P356.
- (2) If output frequency (P001 = 0) is selected as the display, the corresponding setpoint is flashed on the display approximately every 1.5 seconds while the inverter is stopped.
- (3) The inverter is programmed at the factory for standard applications on Siemens standard motors. When using other motors it is necessary to enter the specifications from the motor's rating plate into parameters P080 to P085 (see Figure 4.2.1). **Note: Access to these parameters is not possible unless P009 = 002 or 003.**
- (4) A separately-driven fan and/or a temperature sensor must be provided in the motor to protect it if the drive is operated continuously below approx. 15 Hz drive inverter frequency

Figure 4.2.1: Typical Motor Rating Plate Example

Note: Ensure that the inverter is configured correctly to the motor, i.e. in the above example delta terminal connection is for 220 V.

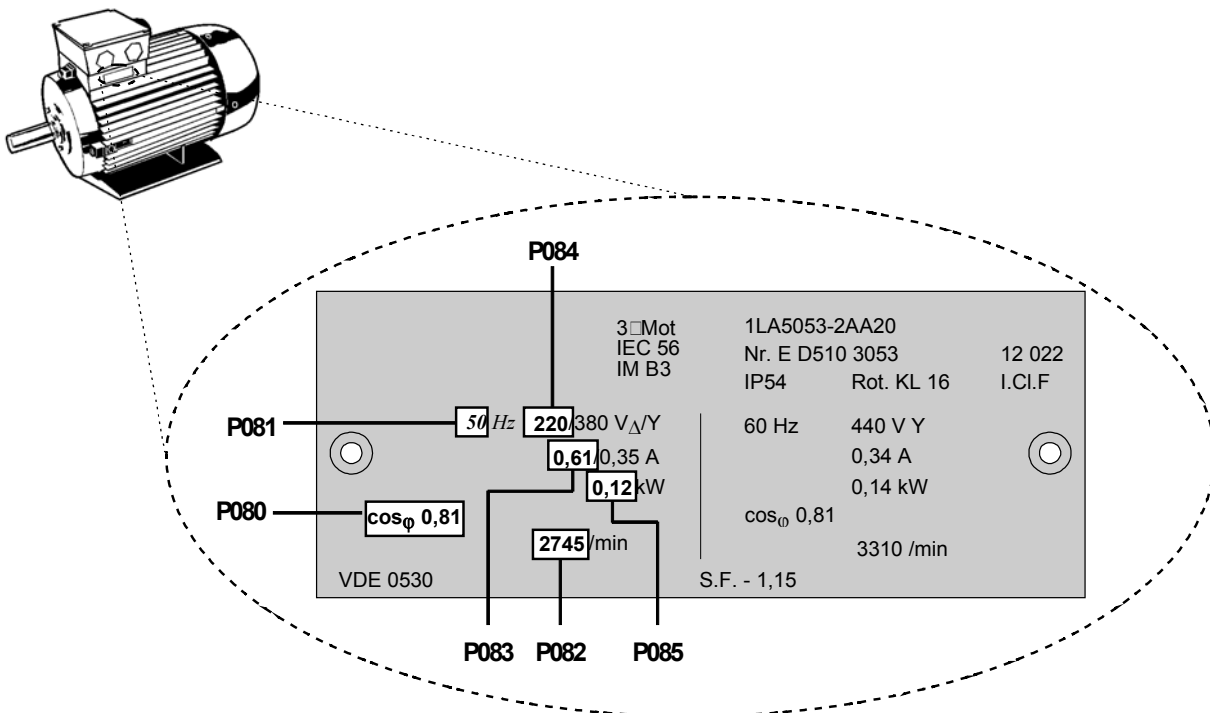

4.2.2 Initial Testing

1. Check that all cables have been connected correctly (see section 2 or 3) and that all relevant product and plant/location safety precautions have been complied with.
2. Apply mains power to the inverter.
3. Ensure that it is safe to start the motor. Press the RUN button on the inverter. The display will change to **5.0** and the motor shaft will begin to turn. It will take 1 second for the inverter to ramp-up to 5 Hz.
4. Check that the motor rotates in the direction required. Press the FORWARD / REVERSE button if necessary.
5. Press the Stop button. The display will change to **0.0** and the motor will slow down, achieving a complete stop after 1 second.

4.2.3 Basic Operation - 10 Step Guide

The basic method of setting up the inverter for use is described below. This method uses a digital frequency setpoint and requires only the minimum number of parameters to be changed from their default settings. It assumes that a standard Siemens four-pole motor is connected to the inverter (see section 4.2.1 if another motor type is being used).

Step/Action	Button	Display
1. Apply mains power to the inverter. The display will alternate between the actual frequency (0.0 Hz) and the requested frequency setpoint (5.0 Hz default).		
2. Press the parameterisation button.		
3. Press the Δ button until parameter P005 is displayed.		
4. Press P to display the present frequency setpoint (5 Hz is the factory default setting).		
5. Press the Δ button to set the desired frequency setpoint (e.g. 35 Hz).		
6. Press P to lock the setting into memory.		
7. Press the ∇ button to return to P000.		
8. Press P to exit the parameterisation procedure. The display will alternate between the present output frequency and the frequency setpoint.		
9. Start the inverter by pressing the RUN button. The motor shaft will start to turn and the display will show that the inverter is ramping up to the setpoint of 35 Hz. Note The setpoint will be achieved after 7 seconds (default ramp-up time, defined by P002 is 10s to reach 50 Hz, the default maximum motor frequency, P013). If required, the motor's speed (i.e. frequency) can be varied directly by using the Δ ∇ buttons. (Set P011 to 001 to enable the new frequency setting to be retained in memory during periods when the inverter is not running.)		
10. Switch the inverter off by pressing the STOP button. (see section 5.4) The motor will slow down and come to a controlled stop. Note Full stop will be achieved after 7 seconds (default ramp-down time, defined by P003 is 10 s from 50 Hz, the default value P013).		

5. OPERATING MODES

5.1 Digital Control

For a basic start-up configuration using digital control, proceed as follows:

- (1) Connect control terminal 9 to terminal 5 via a simple on/off switch. This sets up the inverter for clockwise rotation of the motor shaft (default).
- (2) Secure all covers to the unit and then apply mains power to the inverter. Set parameter P009 to 002 or 003 to enable all parameters to be adjusted.
- (3) Check that parameter P006 is set to 000 to specify digital setpoint.
- (4) Set parameter P007 to 000 to specify digital input (i.e. DIN1, terminal 5 in this case) and disable the front panel controls.
- (5) Set parameter P005 to the desired frequency setpoint.
- (6) Set parameters P080 to P085 in accordance with the rating plate on the motor (see *Figure 4.2.1*).
- (7) Set the external on/off switch to ON. The inverter will now drive the motor at the frequency set by P005.

5.2 Analogue Control

For a basic start-up configuration using analogue voltage control, proceed as follows:

- (1) Connect control terminal 9 to terminal 5 via a simple on/off switch. This sets up the motor for clockwise rotation (default).
- (2) Connect a 4.7 k Ω potentiometer to the control terminals as shown in Figures 2.2.4 and 2.2.6 (MMV) (Figures 3.2.2 and 3.2.4 (MDV)) or connect pin 2 (0V) to pin 4 and a 0 - 10 V signal between pin 2 (0V) and pin 3 (AIN+).
- (3) Set the Analogue Input 1 Configuration DIP selector switches 1, 2 and 3 for voltage (V) input. (see *Figure 3.2.2-3.2.4, Section 4.1.2*)
- (4) Secure all covers to the unit and then apply mains power to the inverter. Set parameter P009 to 002 or 003 to enable all parameters to be adjusted.
- (5) Set parameter P006 to 001 to specify analogue setpoint.
- (6) Set parameter P007 to 000 to specify digital input and disable the front panel controls.
- (7) Set parameters P021 and P022 to specify the minimum and maximum output frequency settings.
- (8) Set parameters P080 to P085 in accordance with the rating plate on the motor (see *Figure 4.2.1*).
- (9) Set the external on/off switch to ON. Turn the potentiometer (or adjust the analogue input control voltage) until the desired frequency is displayed on the inverter.

5.3 Motor Control Modes

The MICROMASTER Vector and MIDIMASTER Vector inverters have four different modes of operation which control the relationship between the voltage supplied by the inverter and the speed of the motor. The motor control mode of operation is selected at P077:

- Linear voltage/frequency Operation.
- Flux Current Control (FCC) which is used to maintain full flux conditions in the motor.
- Quadratic voltage/frequency relationship which is used for pumps and fans.
- Sensorless Vector. The inverter calculates the changes required in output voltage to maintain the desired motor speed.

These modes are described in more detail below.

5.3.1 Linear Voltage to Frequency (V/f) (P077 = 0 or 2)

This mode is used for synchronous motors or motors connected in parallel. Each motor should be installed with a thermal overload relay if two or more motors are driven simultaneously by the inverter.

In many cases, when default factory parameters are used, the default stator resistance set in P089 will generally suit the default power rating set in P085. Should the inverter and motor ratings differ, an automatic Stator Resistance calibration should be performed by setting P088 =1. Continuous Boost (P078) and Starting Boost (P079) are dependent on the value of Stator Resistance - too high a value may cause overcurrent trips or motor overheating.

5.3.2 Flux Current Control (FCC) Operation (P077 = 1)

Flux Current Control operates by monitoring and maintaining the motor flux current continuously. This ensures that the best performance and efficiency are obtained. FCC is not as complex as SVC, and therefore is easier to set up and operate.

Note: This mode can result in reduced power consumption.

5.3.3 Sensorless Vector Control (SVC) Operation (P077 = 3)

When SVC operating mode is selected (P077=3), the inverter uses an internal mathematical model of the motor, together with accurate current sensing, to calculate the position and speed of the rotor. It is therefore able to optimise the applied voltage and frequency to the motor to give improved performance.

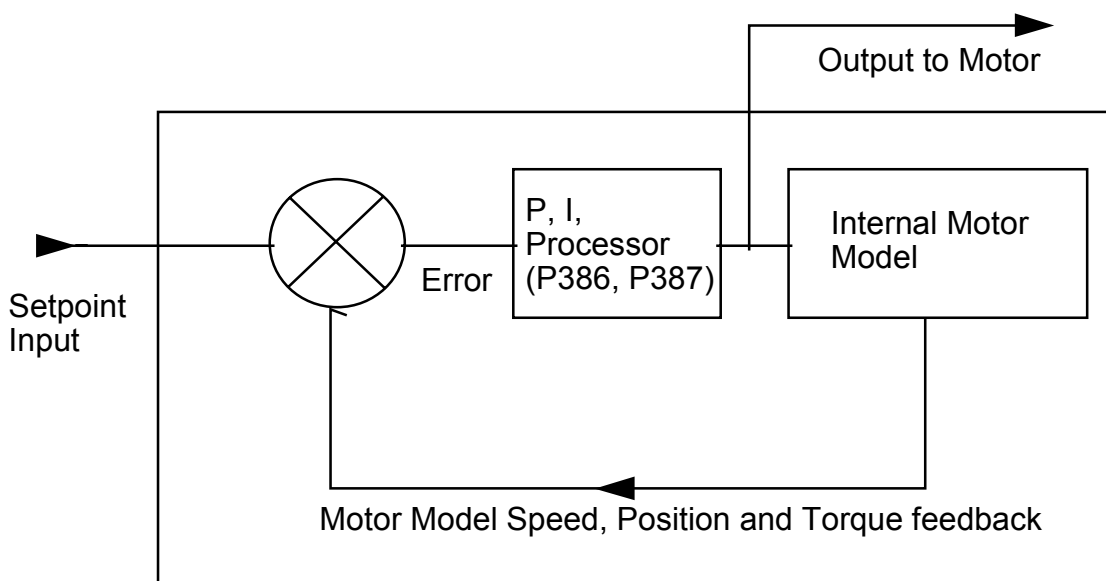

Figure 5.3.3 : MICROMASTER Vector sensorless Vector operation

Although there is no position or speed feedback from the motor, the control system is a closed loop system because it compares the internal motor model performance with the desired performance. The system must therefore be carefully set up and stabilised for best performance.

Setting up SVC Operation

1. Set the correct Motor parameter settings in Parameters P080 to P085.
2. Select Sensorless Vector Operating mode P077 = 3
3. Ensure that the motor is cold and apply a run command. The display will show CAL to indicate that it is measuring the motor stator resistance. After a few seconds the motor will run. Calibration only occurs the first time that a run command is given following P077 being set to 3. It can be forced by changing P077 from SVC operation and back again, or by selecting P088 =1 (Stator Resistance Calibration). Interrupting the calibration process by disconnecting the power or removing the run command may give erroneous results and calibration should be repeated. If motor parameters are changed recalibration is also recommended.
4. Like any control system, SVC must be stabilised by setting the Gain (P386) and Integral (P387) terms. Actual values and setting up is determined by testing, but the following procedure is suggested:

Whilst the inverter is operating under typical conditions, increase the value of P386, the loop gain, until the first signs of speed instability occur. The setting should then be reduced slightly (approx. 10%) until stability is restored. As a guide, the optimum setting required will be proportional to the load inertia.

For example: $P386 = \frac{\text{Load inertia} + \text{motor shaft inertia}}{\text{motor shaft inertia}}$

P387, the integral term, may now be adjusted. Again, whilst operating the inverter under typical conditions, increment this parameter until the first signs of speed instability occur. The setting should then be reduced slightly (approx. 30%) until stability is restored.

If fault code F016 occurs, this indicates that SVC is unstable and further adjustment or recalibration is needed. F001, DC link overvoltage can also be caused by instability in SVC operating mode.

For further information concerning SVC operation refer to Application Note "Sensorless Vector Control", which may be obtained from <http://www.siemens.com/micromaster> or a Siemens Sales Office.

Note: This mode gives the best flux control and higher torque.

5.4 Stopping the Motor

Stopping can be achieved in several ways:

- Cancelling the ON command on the terminals or pressing the OFF button (O) on the front panel causes the inverter to Ramp-down at the selected Ramp-down rate (see P003).
- OFF2 - operation causes the motor to coast to a standstill (parameters P051 to P055 or P356 set to 4).
- OFF3 - operation causes rapid braking (parameters P051 to P055 or P356 set to 5).
- DC injection braking up to 250% produces more effective braking to provide a quicker stop after cancellation of the ON command (see P073).
- Resistive braking for MMV (see parameter P075).
- Compound braking (see P066)

5.5 If the Motor Does Not Start Up

If the display shows a fault code, refer to section 7.

If the motor does not start up when the ON command has been given, check that the ON command is valid, check if a frequency setpoint has been entered in P005 and check that the motor specifications have been entered correctly under parameters P080 to P085.

If the inverter is configured for operation via the front panel (P007 = 001) and the motor does not start when the RUN button is pressed, check that P121 = 001 (RUN button enabled).

If the motor does not run after parameters have been changed accidentally, reset the inverter to the factory default parameter values by setting parameter **P944** to **1** and then pressing **P**.

5.6 Local and Remote Control

The inverter can be controlled either locally (default), or remotely via a USS data line connected to the internal interface terminals (24 and 25) or to the RS485 D-type connector on the front panel. (Refer to parameter P910 in section 6 for the available remote control options.)

When local control is used, the inverter can only be controlled via the front panel or the control terminals. Control commands, setpoints or parameter changes received via the RS485 interface have no effect.

For remote control, the serial interface is designed as a 2-wire connection for bi-directional data transmission. Refer to parameter P910 in section 6 for the available remote control options.

Note: Only one RS485 connection is allowed. Use either the front panel D-type interface [e.g. to connect an Clear Text Display(OPM2)] or terminals 24 and 25, **but not both**.

When operating via remote control the inverter will not accept control commands from the terminals. *Exception: OFF2 or OFF3 can be activated via parameters P051 to P055 and P356 (see section 6).*

Several inverters can be connected to an external control unit at the same time. The inverters can be addressed individually.

Note: If the inverter has been set up to operate via the serial link but does not run when an ON command is received, try reversing the connections to terminals 24 and 25 .

For further information, refer to the following documents:

- E20125-B0001-S302-A1 Application of the USS Protocol in SIMOVERT Units 6SE21 and MICROMASTER (German)
- E20125-B0001-S302-A1-7600 Application of the USS Protocol in SIMOVERT Units 6SE21 and MICROMASTER (English)

5.7 Closed Loop Control

5.7.1 General Description

The MICROMASTER provides a PID control function for closed loop control (see Figure 5.7.1). PID control is ideal for temperature or pressure control, or other applications where the controlled variable changes slowly or where transient errors are not critical. This control loop is **not** suitable for use in systems where fast response times are required. When closed loop process control is enabled (P201 = 001), all setpoints are calibrated between zero and 100%, i.e. a setpoint of 50.0 = 50%.

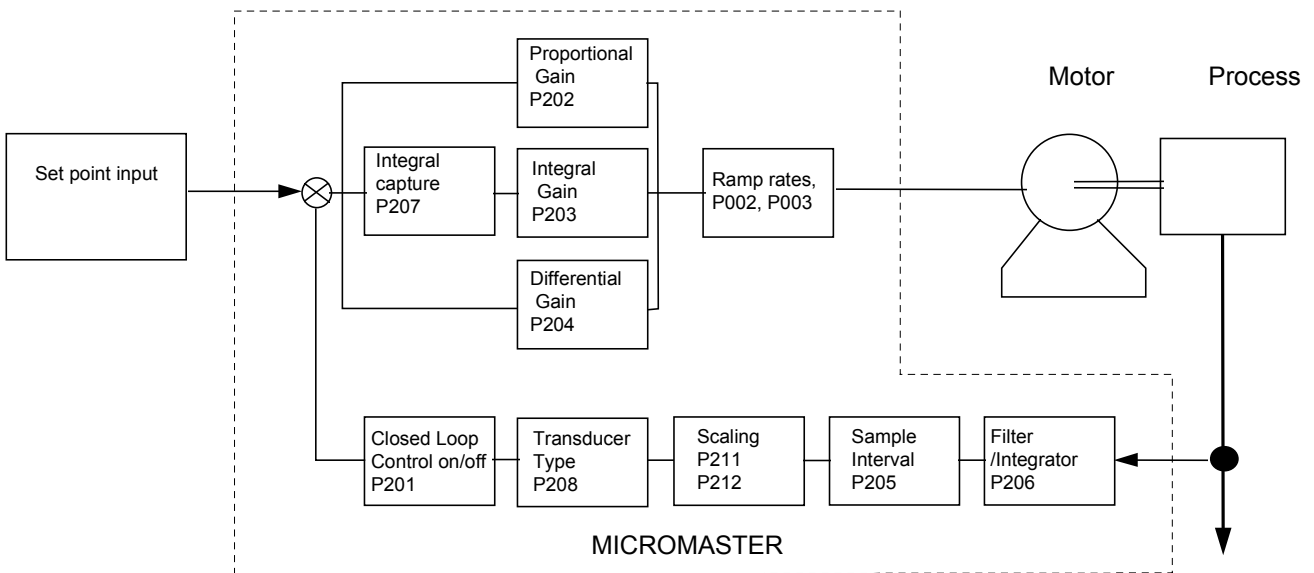

MICROMASTER Closed loop PID control - Block Diagram

Figure : 5.7.1 – MICROMASTER / MIDIMASTER VECTOR Closed loop PID control

5.7.2 Hardware Set-up

Make sure that the DIP selector switches 4 and 5 are correctly set (see Figure 4.1.2) and in agreement with P323 for unipolar voltage or current feedback signal inputs. Connect the external feedback transducer between control terminals 10 and 11 (analogue input 2). This analogue input accepts a 0/2 - 10 V or a 0/4 - 20 mA input signal (determined by the setting of the DIP selector switches 4 and 5 and P323), has 10-bit resolution and permits a differential (floating) input. 15 V dc power for the feedback transducer can be supplied from terminal 9 on the control block.

5.7.3 Parameter Settings

Closed loop process control cannot be used unless P201 is first set to 001. Most of the parameters associated with closed loop process control are shown in Figure 5.7.1. Other parameters which are also associated with closed loop process control are as follows:

P010 (only if P001 = 1, 4, 5, 7 or 9)

P061 (value = 012 or 013)

P220

Descriptions of all closed loop process control parameters are provided in section 6. For detailed information about PID operation, refer to the application note "Closed Loop Control", which may be obtained from <http://www.siemens.com/micromaster> or a Siemens sales office.

6. SYSTEM PARAMETERS

Parameters can be changed and set using the keypad on the front panel (see Figure 4.1.1) to adjust the desired properties of the inverter, such as ramp times, minimum and maximum frequencies, etc. The parameter numbers selected and the setting of the parameter values are indicated on the four digit LED display.

Note: If the Δ or ∇ button is pressed momentarily, the values change step by step. If the button is pressed for a longer time, the values scroll through rapidly.

Access to parameters is determined by the value set in P009. Make sure that the key parameters necessary for the application have been programmed.

Note: In the following parameter table:

- '•' Indicates parameters that can be changed during operation.
- '☆☆☆☆' Indicates that the value of this factory setting depends on the rating of the inverter.

Increased Parameter Resolution

To increase the resolution to 0.01 when changing frequency parameters, instead of pressing P momentarily to return to the parameter display, keep the button pressed until the display changes to '-.n0' (n = the current tenths value, e.g. if the parameter value = '055.8' then n = 8). Press Δ or ∇ to change the value (all values between .00 and .99 are valid) and then press P twice to return to the parameter display.

Resetting to Factory Defaults

If parameters are changed accidentally, all parameters can be reset to their default values by setting parameter **P944** to **1** and then pressing **P**.

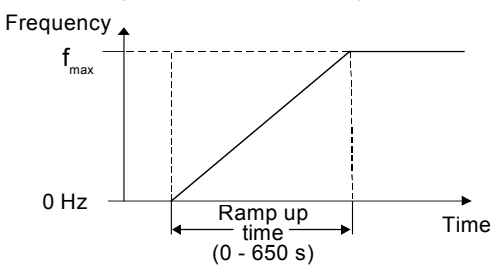
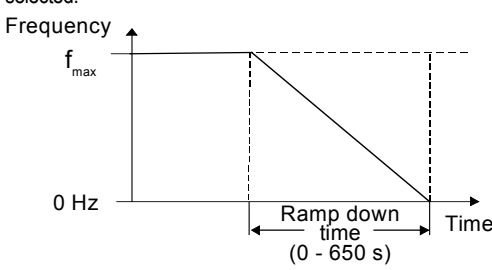
Parameter	Function	Range [Default]	Description / Notes
P000	Operating display	-	<p>This displays the output selected in P001.</p> <p>In the event of a failure, the relevant fault code (Fnnn) is displayed (see section 7) or the display flashes in the event of a warning (see P931) or If output frequency has been selected (P001 = 0) and the inverter is in stand-by mode, the display alternates between the setpoint frequency and the actual output frequency which is zero Hz.</p>
P001 ●	Display mode	0 - 9 [0]	<p>Display selection:</p> <ul style="list-style-type: none"> 0 = Output frequency (Hz) 1 = Frequency setpoint (i.e. speed at which inverter is set to run) (Hz) 2 = Motor current (A) 3 = DC-link voltage (V) 4 = Motor torque (% nominal) 5 = Motor speed (rpm) 6 = USS serial bus status (see section 9.2) 7 = PID Feedback signal (%) 8 = Output voltage (V) 9 = Instantaneous rotor / shaft frequency (Hz). Note: Applicable only for Sensorless Vector control mode. <p>Notes: 1. The display can be scaled via P010. 2. When the inverter is operating in Sensorless Vector Control mode (P077 = 3) the display shows actual rotor / shaft speed in Hz. When the inverter is operating in V/f or FCC modes (P077 = 0, 1 or 2) the display shows inverter output frequency in Hz.</p> <p>WARNING: In Sensorless Vector Control mode (P077 = 3) the display shows 50Hz when a 4-pole motor is rotating at 1500rpm which may be slightly higher than the nominal speed shown on the motor rating plate.</p>
P002 ●	Ramp-up time (seconds) MMV MDV550/2, 750/2, 750/3, 1100/3, 220/4, 400/4, 550/4, 750/4, 1100/4. MDV1100/2, 1500/2, 1850/2, 2200/2, 1500/3, 1850/3, 2200/3, 3000/3, 3700/3, 1500/4, 1850/4, 2200/4, 3000/4, 3700/4. MDV3000/2, 3700/2, 4500/2, 4500/3, 5500/3, 7500/3.	0 - 650.0 [10.0] [10.0] [20.0] [40.0]	<p>This is the time taken for the motor to accelerate from standstill to the maximum frequency as set in P013. Setting the Ramp-up time too short can cause the inverter to trip (fault code F002 - overcurrent).</p> <p>Frequency</p>  <p>0 Hz</p> <p>f_{max}</p> <p>Time</p> <p>Ramp up time (0 - 650 s)</p>
P003 ●	Ramp-down time (seconds) MMV MDV550/2, 750/2, 750/3, 1100/3, 220/4, 400/4, 550/4, 750/4, 1100/4. MDV1100/2, 1500/2, 1850/2, 2200/2, 1500/3, 1850/3, 2200/3, 3000/3, 3700/3, 1500/4, 1850/4, 2200/4, 3000/4, 3700/4. MDV3000/2, 3700/2, 4500/2, 4500/3, 5500/3, 7500/3.	0 - 650.00 [10.0] [10.0] [20.0] [40.0]	<p>This is the time taken for the motor to decelerate from maximum frequency (P013) to standstill. Setting the Ramp-down time too short can cause the inverter to trip (fault code F001 -DC Link overvoltage).</p> <p>This is also the period for which DC injection braking is applied when P073 is selected.</p> <p>Frequency</p>  <p>0 Hz</p> <p>f_{max}</p> <p>Time</p> <p>Ramp down time (0 - 650 s)</p>

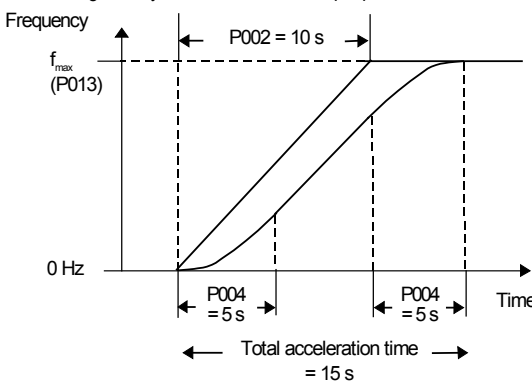
Parameter	Function	Range [Default]	Description / Notes
P004	Smoothing Time (seconds)	0 - 40.0 [0.0]	<p>Used to smooth the acceleration/deceleration of the motor (useful in applications where it is important to avoid 'jerking', e.g. conveyor systems, textiles, etc.).</p> <p>Smoothing is only effective if the Ramp-up and/or down time exceeds 0.3 s.</p>  <p>Note: The smoothing curve for deceleration is also affected by the Ramp-up gradient (P002). Therefore, the Ramp-down time is also affected by changes to P002.</p>
P005	Digital frequency setpoint (Hz)	0 - 650.00 [5.00]	Sets the frequency that the inverter will run at when operated in digital mode. Only effective if P006 = 0 or 3.
P006	Frequency setpoint source selection	0 - 3 [0]	<p>Selects the mode of control of the frequency setpoint for the inverter.</p> <ul style="list-style-type: none"> 0 = Digital motorised potentiometer. The inverter runs at the frequency set in P005 and can be controlled with the Δ and ∇ pushbuttons (motorised potentiometer). Alternatively, if P007 is set to zero, the frequency may be increased or decreased by setting any two of the digital inputs (P051 to P055 or P356) to values of 11 and 12. 1 = Analogue. Control via analogue input signal. 2 = Fixed frequency. Fixed frequency is only selected if the value of at least one of the digital inputs (P051 to P055 or P356) = 6 17 or 18. 3 = Digital setpoint addition. Requested frequency = digital frequency (P005) + fixed frequencies (P041 to P044, P046 to P049) as selected. <p>Notes: (1) If P006 = 1 and the inverter is set up for operation via the serial link, the analogue inputs remain active. (2) Motorised potentiometer setpoints via digital inputs are stored upon power-down when P011 = 1.</p>
P007	Keypad control	0 - 1 [1]	<ul style="list-style-type: none"> 0 = RUN, JOG and REVERSE are disabled. Control is via digital inputs (see parameters P051 - P055 and P356). Δ and ∇ may still be used to control frequency provided that P124 = 1 and a digital input has not been selected to perform this function. 1 = Front panel buttons can be selectively enabled or disabled depending on the setting of parameters P121 - P124. <p>Note: The digital inputs for RUN, JOG and increase/decrease frequency are disabled.</p>
P009	Parameter protection setting	0 - 3 [0]	<p>Determines which parameters can be adjusted:</p> <ul style="list-style-type: none"> 0 = Only parameters from P001 to P009 can be read/set. 1 = Parameters from P001 to P009 can be set and all other parameters can only be read. 2 = All parameters can be read/set but P009 automatically resets to 0 when power is removed. 3 = All parameters can be read/set.
P010	Display scaling	0 - 500.0 [1.00]	<p>Scale factor for display when P001 = 0, 1, 4, 5, 7 or 9.</p> <p>Four digit resolution.</p>

Parameter	Function	Range [Default]	Description / Notes
P011	Frequency setpoint memory	0 - 1 [0]	<p>0 = Disabled</p> <p>1 = Enabled after switch-off. i.e. the setpoint alterations made with the Δ / ∇ buttons are stored even when power has been removed from the inverter.</p>
P012 ●	Minimum motor frequency (Hz)	0 - 650.00 [0.00]	Sets the minimum motor frequency (must be less than the value of P013).
P013 ●	Maximum motor frequency (Hz)	0.01-650.00 [50.00]	<p>Sets the maximum motor frequency.</p> <p>CAUTION: To maintain stable operation when in sensorless vector control mode (P077=3), the maximum motor frequency (P013), should not exceed 3x nominal rating plate motor frequency (P081).</p>
P014 ●	Skip frequency 1 (Hz)	0 - 650.00 [0.00]	A skip frequency can be set with this parameter to avoid the effects of resonance of the inverter. Frequencies within +/- (the value of P019) of this setting are suppressed. Stationary operation is not possible within this suppressed frequency range - the range is just passed through. Setting P014=0 disables this function.
P015 ●	Automatic restart after mains failure.	0 - 1 [0]	<p>Setting this parameter to '1' enables the inverter to restart automatically after a mains break or 'brownout', provided the external run/stop switch, connected to a digital input, is still closed, P007 = 0 and P910 = 0, 2 or 4.</p> <p>0 = Disabled</p> <p>1 = Automatic restart</p>
P016 ●	Start on the fly	0 - 4 [0]	<p>Allows the inverter to start onto a spinning motor.</p> <p>Under normal circumstances the inverter runs the motor up from 0 Hz. However, if the motor is still spinning or is being driven by the load, it will undergo braking before running back up to the setpoint - this can cause an overcurrent trip. By using a flying restart, the inverter 'homes in' on the motor's speed and runs it up from that speed to the setpoint. (Note: If the motor has stopped or is rotating slowly, some 'rocking' may occur as the inverter senses the direction of rotation prior to restarting.)</p> <p>0 = Normal restart</p> <p>1 = Flying restart after power up, fault or OFF2 (if P018 = 1).</p> <p>2 = Flying restart every time (useful in circumstances where the motor can be driven by the load).</p> <p>3 = As P016 = 1 except that the inverter will only attempt to restart the motor in the direction of the requested setpoint. The motor is prevented from 'rocking' backwards and forwards during the initial frequency scan.</p> <p>4 = As P016 = 2 except that the inverter will only attempt to restart the motor in the direction of the requested setpoint. The motor is prevented from 'rocking' backwards and forwards during the initial frequency scan.</p> <p>Note: For MIDIMASTER Vector units, it is recommended that if P016 > 0 then P018 should be set to '1'. This will ensure correct re-starting if the inverter fails to re-synchronise on the initial attempt.</p> <p>IMPORTANT:</p> <p>When P016 > 0, care must be taken to set up the motor nameplate data (parameters P080 to P085) and to perform an auto stator resistance calibration (P088=1) on a cold motor. Recommended maximum operating frequency should be less than 120 Hz.</p>
P017 ●	Smoothing type	1 - 2 [1]	<p>1 = Continuous smoothing (as defined by P004).</p> <p>2 = Discontinuous smoothing. This provides a fast unsmoothed response to STOP commands and requests to reduce frequency.</p> <p>Note: P004 must be set to a value > 0.0 for this parameter to have any effect.</p>

Parameter	Function	Range [Default]	Description / Notes
P018	● Automatic restart after fault	0 - 1 [0]	Automatic restart after fault: 0 = Disabled 1 = The inverter will attempt to restart up to 5 times after a fault. If the fault is not cleared after the 5th attempt, the inverter will remain in the fault state. The display flashes during this condition. WARNING: While waiting to re-start, the display will flash. This means that a start is pending and may happen at any time. Fault codes can be observed in P140 and P930.
P019	● Skip frequency bandwidth (Hz)	0.00 - 10.00 [2.00]	Frequencies set by P014, P027, P028 and P029 that are within +/- the value of P019 of all skip frequencies are suppressed.
P021	● Minimum analogue frequency (Hz)	0 - 650.00 [0.00]	Frequency corresponding to the lowest analogue input value, i.e. 0 V/0 mA or 2 V/4 mA, determined by P023 and the settings of the DIP selector switches 1, 2 and 3 (see Figure 4.1.2). This can be set to a higher value than P022 to give an inverse relationship between analogue input and frequency output (see diagram in P022).
P022	● Maximum analogue frequency (Hz)	0 - 650.00 [50.00]	Frequency corresponding to the highest analogue input value, i.e. 10 V or 20 mA, determined by P023 and the setting of the DIP selector switches 1, 2 and 3 (see Figure 4.1.2). This can be set to a lower value than P021 to give an inverse relationship between analogue input and frequency output. i.e.

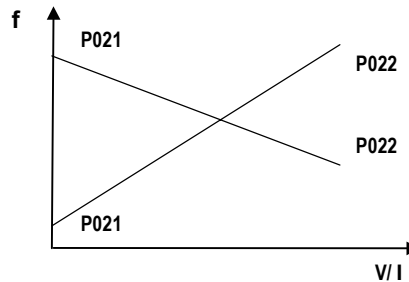

Note: The output frequency is limited by values entered for P012/P013.

Parameter	Function	Range [Default]	Description / Notes
-----------	----------	-----------------	---------------------

P023 ● Analogue input 1 type

Range: 0 - 3 [0]

Sets analogue input type for analogue input 1, in conjunction with the settings of the DIP selector switches 1, 2 and 3 (see Figure 4.1.2) :

0 = 0 V to 10 V / 0 to 20 mA Unipolar input
 1 = 2 V to 10 V / 4 to 20 mA Unipolar input
 2 = 2 V to 10 V / 4 to 20 mA Unipolar input with controlled start / stop when using analogue input control.
 3 = -10V to +10V Bipolar input. -10V corresponds to left rotation at speed set in P021, +10V corresponds to right rotation at speed set in P022

Note: Setting P023 = 2 will not work unless the inverter is under full local control (i.e. P910 = 0 or 4) and $V \geq 1$ V or 2mA.

WARNING: The inverter will automatically start when voltage goes above 1V. This equally applies to both analogue and digital control (i.e. P006 = 0 or 1)

Bi-polar Input Operation

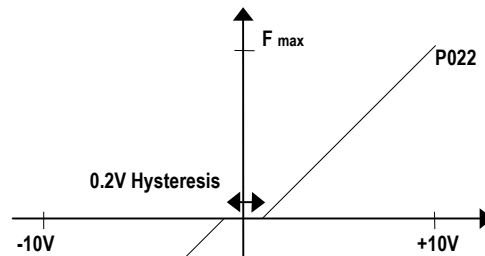

P024 ● Analogue setpoint addition

Range: 0 - 2 [0]

If the inverter is not in analogue mode (P006 = 0 or 2), setting this parameter to:

0 = No addition to basic setpoint frequency as defined in P006.
 1 = Addition of analogue input 1 to the basic setpoint frequency as defined in P006
 2 = Scaling of basic setpoint (P006) by analogue input 1 in the range 0 -100%.

P025 ● Analogue output 1

Range: 0 - 105 [0]

This provides a method of scaling the analogue output 1 in accordance with the following table:
 Use range 0 - 5 if minimum output value = 0 mA.
 Use range 100 - 105 if minimum output value = 4 mA

P025 =	Selection	Analogue Output Range Limits	
		0/4 mA	20 mA
0/100	Output frequency	0 Hz	Output frequency (P013)
1/101	Frequency setpoint	0 Hz	Frequency setpoint (P013)
2/102	Motor current	0 A	Max. overload current (P083 x P086 / 100)
3/103	DC-link voltage	0 V	1023 Vdc
4/104	Motor torque	-250%	+250% (100% = P085 x 9.55 / P082 Nm)
5/105	Motor RPM	0	Nominal motor RPM (P082)
6/106	Motor magnetising current	0 A	Max. overload current (P083 x P186 / 100)
7/107	Motor torque producing current (centre zero)	0 A Max regenerative torque	Max. overload current i.e. accelerating torque (P083 x P186 / 100)

Parameter	Function	Range [Default]	Description / Notes
P026	● Analogue output 2 (MDV only)	0 - 105 [0]	This provides a method of scaling the analogue output 2 in accordance with the table shown in P025.
P027	● Skip frequency 2 (Hz)	0 - 650.00 [0.00]	See P014.
P028	● Skip frequency 3 (Hz)	0 - 650.00 [0.00]	See P014.
P029	● Skip frequency 4 (Hz)	0 - 650.00 [0.00]	See P014.
P031	● Jog frequency right (Hz)	0 - 650.00 [5.00]	Jogging is used to advance the motor by small amounts. It is controlled via the JOG button or with a non-latching switch on one of the digital inputs (P051 to P055 and P356). If jog right is enabled for one of these digital inputs (e.g. P051-55 or P356 =7) or if the Job Button is pressed this parameter controls the frequency at which the inverter will run when the switch is closed. Unlike other setpoints, it can be set lower than the minimum frequency.
P032	● Jog frequency left (Hz)	0 - 650.00 [5.00]	If jog left is enabled (e.g. P051-55 or P356 = 8), this parameter controls the frequency at which the inverter will run when the switch is closed. Unlike other setpoints, it can be set lower than the minimum frequency.
P033	● Jog Ramp-up time (seconds)	0 - 650.0 [10.0]	This is the time taken to accelerate from 0 Hz to maximum frequency (P013) for jog functions. It is not the time taken to accelerate from 0 Hz to the jog frequency. If one of the digital inputs is programmed to select jog ramp times, the corresponding digital input can be used to select the ramp time set by this parameter instead of the normal Ramp-up time set by P002.
P034	● Jog Ramp-down time (seconds)	0 - 650.0 [10.0]	This is the time taken to decelerate from maximum frequency (P013) to 0 Hz for jog functions. It is not the time taken to decelerate from the jog frequency to 0 Hz. If one of the digital inputs is programmed to select jog ramp times, the corresponding digital input can be used to select the ramp time set by this parameter, instead of the normal Ramp-down time set by P003.

Parameter	Function	Range [Default]	Description / Notes
-----------	----------	-----------------	---------------------

P040 ● Positioning function

0 - 1
[0]

0 - Disabled
1 - Under normal operation the ramp-down time is defined as the time taken to ramp-down from the value set in P013 to 0. Setting P040 to 1 will automatically re-scale the ramp down time so that the motor will always stop in the same position regardless of operating frequency.

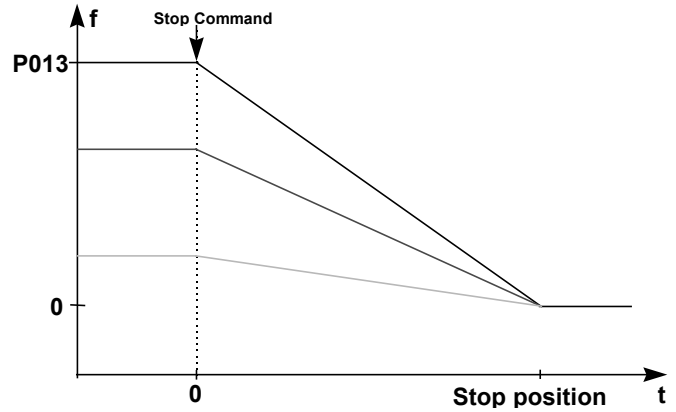

e.g. P003 = 1s, P013 = 50Hz, P012 = 0Hz.

If the motor is running at 50Hz and a stop command applied, the motor will stop in 1second. If the motor is running at 25Hz, the motor will stop in 2 seconds and if the motor is running at 5Hz, the motor will stop in 10 seconds. In each case, the motor will stop at the same position.

P041 ●	Fixed frequency 1 (Hz)	0 - 650.00 [5.00]	Valid if P006 = 2 and P055 = 6 or 18, or P053-55=17
P042 ●	Fixed frequency 2 (Hz)	0 - 650.00 [10.00]	Valid if P006 = 2 and P054 = 6 or 18, or P053-55=17
P043 ●	Fixed frequency 3 (Hz)	0 - 650.00 [15.00]	Valid if P006 = 2 and P053 = 6 or 18, or P053-55=17
P044 ●	Fixed frequency 4 (Hz)	0 - 650.00 [20.00]	Valid if P006 = 2 and P052 = 6 or 18 , or P053-55=17

Parameter	Function	Range [Default]	Description / Notes
-----------	----------	--------------------	---------------------

P045 Inversion fixed setpoints for fixed frequencies 1 - 4 0 - 7
[0] Sets the direction of rotation for the fixed frequency:

	FF 1	FF 2	FF3	FF 4
P045 = 0	⇒	⇒	⇒	⇒
P045 = 1	⇐	⇒	⇒	⇒
P045 = 2	⇒	⇐	⇒	⇒
P045 = 3	⇒	⇒	⇐	⇒
P045 = 4	⇒	⇒	⇒	⇐
P045 = 5	⇐	⇐	⇒	⇒
P045 = 6	⇐	⇐	⇐	⇒
P045 = 7	⇐	⇐	⇐	⇐

⇒ Fixed setpoints not inverted.
⇐ Fixed setpoints inverted.

P046 ● Fixed frequency 5 (Hz) 0 - 650.00 Valid if P006 = 2 and P051 = 6 or 18. , or P053-55=17
[25.0]

P047 ● Fixed frequency 6 (Hz) 0 - 650.00 Valid if P006 = 2 and P356 = 6 or 18, or P053-55=17
[30.0]

P048 ● Fixed frequency 7 (Hz) 0 - 650.00 Valid if P006 = 2, and P053-55=17
[35.0]

P049 ● Fixed frequency 8 (Hz) 0 - 650.00 Valid if P006 = 2, and P053-55=17
[40.0]

P050 Inversion fixed setpoints for fixed frequencies 5 - 8 0 - 7
[0] Sets the direction of rotation for the fixed frequency:

	FF 5	FF 6	FF7	FF8
P050 = 0	⇒	⇒	⇒	⇒
P050 = 1	⇐	⇒	⇒	⇒
P050 = 2	⇒	⇐	⇒	⇒
P050 = 3	⇒	⇒	⇐	⇒
P050 = 4	⇒	⇒	⇒	⇐
P050 = 5	⇐	⇐	⇒	⇒
P050 = 6	⇐	⇐	⇐	⇒
P050 = 7	⇐	⇐	⇐	⇐

⇒ Fixed setpoints not inverted
⇐ Fixed setpoints inverted

Parameter	Function	Range [Default]	Description / Notes			
P051	Selection control function, DIN1 (terminal 5), fixed frequency 5.	0 - 24 [1]	Value	Function of P051 to P055 and P356	Function, low state	Function, high state
P052	Selection control function, DIN2 (terminal 6), fixed frequency 4.	0 - 24 [2]	0	Input disabled	-	-
P053	Selection control function, DIN3 (terminal 7), fixed frequency 3. If set to 17, this enables the most significant bit of the 3-bit Binary code (see table).	0 - 24 [6]	1	ON right	Off	On right
			2	ON left	Off	On left
			3	Reverse	Normal	Reverse
			4	OFF2(see section 5.4)	OFF2	On
			5	OFF3(see section 5.4)	OFF3	On
			6	Fixed frequencies 1 - 6	Off	On
P054	Selection control function, DIN4 (terminal 8), fixed frequency 2. If set to 17, this enables the middle bit of the 3-bit Binary code (see table).	0 - 24 [6]	7	Jog right	Off	Jog right
			8	Jog left	Off	Jog left
			9	USS operation (P910 = 1 or 3)	Local	(USS, Profi- and CANbus)
			10	Fault reset	Off	Reset on rising edge
P055	Selection control function, DIN5 (terminal 16), fixed frequency 1. If set to 17, this enables the least significant bit of the 3-bit Binary code (see table).	0 - 24 [6]	11	Increase frequency *	Off	Increase
			12	Decrease frequency *	Off	Decrease
			13	Disable analogue input (setpoint is 0.0Hz)	Analogue on 'P' enabled	Analogue disabled
			14	Disable the ability to change parameters	Off	'P' disabled
P356	Selection control function, DIN6 (terminal 17), fixed frequency 6.	0 - 24 [6]	15	Enable dc brake	Normal	Brake on
			16	Use jog ramp times instead of normal ramp times	Off	Jog ramp times
			17	Binary fixed frequency control (fixed frequencies 1 - 8) **	Off	On
			18	Fixed frequencies 1-6, but input high will also request RUN when P007 = 0.	Yes (F012)	On
			19	External trip		No
			20	Watchdog trip (see P057), (minimum pulse width = 20 ms)		Low to High transition re-sets
			21	Note: The first Low-to-High transition initiates the Watchdog timer.	Off	Watchdog timer
			22	Download parameter set 0 from OPM2***	Off	Download
			23	Download parameter set 1 from OPM2***		Download
			24	Switch analogue setpoint	Analogue input 1 active.	Analogue **** input 2 active.

* Only effective when P007 = 0.

** Not available on P051, P052 or P356.

*** The motor must be stopped before downloading begins.
Downloading takes approx. 30 seconds.

**** Top left hand segment in display flashes

Parameter	Function	Range [Default]	Description / Notes
-----------	----------	--------------------	---------------------

Binary Coded Fixed Frequency Mapping			
	DIN3 (P053)	DIN4 (P054)	DIN5 (P055)
FF5 (P046)	0	0	0
FF6 (P047)	0	0	1
FF7 (P048)	0	1	0
FF8 (P049)	0	1	1
FF1 (P041)	1	0	0
FF2 (P042)	1	0	1
FF3 (P043)	1	1	0
FF4 (P044)	1	1	1

Note: If P051 or P052 = 6 or 18 while P053 or P054 or P055 = 17 then the setpoints are added.

Examples: (1) P053 = 17, P054 = 17, P055 = 17:
All 8 fixed frequencies are available
e.g. DIN3 = 1, DIN4 = 1, DIN5 = 0 ⇒ FF3 (P043)
(2) P053 ≠ 17, P054 = 17, P055 = 17:
DIN3 is fixed at zero (only FF5 to FF8 available)
e.g. DIN4 = 1, DIN5 = 0 ⇒ FF7 (P048)

P056	Digital input debounce time	0 - 2 [0]	0 = 12.5 ms 1 = 7.5 ms 2 = 2.5 ms
-------------	-----------------------------	--------------	--

P057	Digital Input Watchdog Trip (seconds)	0.0-650.0 [1.0]	Time interval between expected 'Watchdog kicks' or if this time interval should lapse without a pulse on one of the digital inputs, an F057 trip will occur. (See P051 to P055 and P356)
-------------	---------------------------------------	--------------------	---

P061	Selection relay output RL1	0 - 13 [6]	Sets the relay function, output RL1 (terminals 18,19 and 20)
-------------	----------------------------	---------------	--

Value	Relay function	Active ³
0	No function assigned (relay not active)	Low
1	Inverter is running	High
2	Inverter frequency 0.0 Hz	Low
3	Motor running direction right	High
4	External brake on (see parameters P063/P064)	Low
5	Inverter frequency greater than minimum frequency	High
6	Fault indication ¹	Low
7	Inverter frequency greater than or equal to setpoint	High
8	Warning active ²	Low
9	Output current greater than or equal to P065	High
10	Motor current limit (warning) ²	Low
11	Motor over temperature (warning) ²	Low
12	PID closed loop motor LOW speed limit	High
13	PID closed loop motor HIGH speed limit	High

¹ Inverter switches off (see parameter P930 and P140 to P143 and section 7).

² Inverter does not trip(see parameter P931).

³ 'Active low' = relay OFF/ de-energised or 'Active high' = relay ON/ energised

Note: If the external brake function is used (P061 or P062 = 4) and additional slip compensation is used (P071 ≠ 0), minimum frequency **must be less than 5 Hz** (P012 < 5.00), otherwise the inverter may not switch off.

Warning:Relay operation is not defined during parameter changes and may change unpredictably.

Ensure any equipment connected to the relays will remain safe if the relays change state during parameterisation.

P062	Selection relay output RL2.	0 - 13 [8]	Sets the relay function, output RL2 (terminals 21and 22) (refer to the table in P061).
-------------	-----------------------------	---------------	--

Parameter	Function	Range [Default]	Description / Notes
P063	External brake release delay (seconds)	0 - 20.0 [1.0]	Only effective if the relay output is set to control an external brake (P061 or P062 = 4). In this case when the inverter is switched on, it will run at the minimum frequency for the time set by this parameter before releasing the brake control relay and ramping up (see illustration in P064).
P064	External brake stopping time (seconds)	0 - 20.0 [1.0]	As P063, only effective if the relay output is set to control an external brake. This defines the period for which the inverter continues to run at the minimum frequency after ramping down and while the external brake is applied.

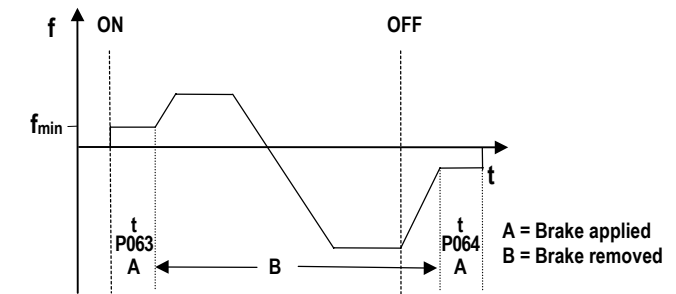

- Notes:
- (1) Settings for P063 and P064 should be slightly longer than the actual time taken for the external brake to apply and release respectively
 - (2) Setting P063 or P064 to too high a value, especially with P012 set to a high value, can cause an overcurrent warning or trip as the inverter attempts to turn a locked motor shaft.

P065	Current threshold for relay (A)	0.0-300.0 [1.0]	This parameter is used when P061 or P062 = 9. The relay switches on when the motor current is greater than the value of P065 and switches off when the current falls to 90% of the value of P065 (hysteresis).
P066	Compound braking	0 - 250 [0]	<p>0 = Off</p> <p>1 to 250 = Defines the level of DC superimposed on the AC waveform, expressed as a percentage of P083. Generally, increasing this value improves braking performance, however, with 400V inverters, a high value in this parameter could cause F001 trips.</p> <p>Note: Compound braking does not operate in Sensorless Vector control mode (P077=3).</p>
P069	Ramp extension disable	0 - 1 [1]	<p>0 - Ramp extension disabled.</p> <p>1 - Ramp extension enabled. Ramp time is increased during current limit, overvoltage limit and slip limit to prevent tripping.</p> <p>Note: Ramp extension does not occur when in vector control (P077=3).</p>
P070	Braking Resistor Duty Cycle (MMV only)	0 - 4 [0]	<p>0 = 5%</p> <p>1 = 10%</p> <p>2 = 20%</p> <p>3 = 50%</p> <p>4 = 100% (i.e. continuous)</p> <p>WARNING: Standard braking resistors for the MICROMASTER Vector are designed for the 5% duty cycle only. Do not select higher duty cycles unless suitably rated resistors are being used to handle the increased power dissipation. The maximum on time for values 0 to 3 is limited according to the brake resistor thermal capacity. Limit is 12 seconds for 5%, increasing to 25 seconds for 50%.</p>

Parameter	Function	Range [Default]	Description / Notes
P071 •	Slip compensation (%)	0 - 200 [0]	<p>The inverter can estimate the amount of slip in an asynchronous motor at varying loads and increase its output frequency to compensate. This parameter 'fine tunes' the compensation for different motors in the range 0 - 200% of the calculated slip.</p> <p>Note: This feature is not active and is not necessary when in Sensorless Vector Control (P077=3).</p> <p>WARNING: This parameter must be set to zero when using synchronous motors or motors that are connected in parallel or over-compensation can cause instability.</p>
P072 •	Slip limit (%)	0 - 500 [250]	<p>0 - 499 - This limits the slip of the motor to prevent 'pull-out' (stalling), which can occur if slip is allowed to increase indefinitely. When the slip limit is reached, the inverter reduces frequency to keep the level of slip below this limit.</p> <p>500 - Disables slip limit warning</p>
P073 •	DC injection braking (%)	0 - 200 [0]	<p>This rapidly stops the motor by applying a DC braking current and holds the shaft stationary until the end of the braking period. Additional heat is generated within the motor. Braking is effective for the period of time set by P003. The DC brake can be activated using DIN1 to DIN6 (see P051 to P055 and P356).</p> <p>WARNING: Frequent use of long periods of dc injection braking can cause the motor to overheat. If DC injection braking is enabled via a digital input then DC current is applied for as long as the digital input is high. This causes heating of the motor.</p>

Parameter	Function	Range [Default]	Description / Notes
-----------	----------	-----------------	---------------------

P074 • I²t motor protection
 Range: 0 - 7 [1]
 Description: Selects the most appropriate curve for the motor derating at low frequencies due to the reduced cooling effect of the shaft mounted cooling fan.

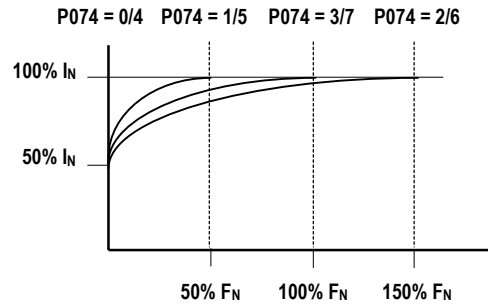

I_N = Nominal motor current (P083)

- 0 = No derating. Suitable for motor with self-cooled or fan powered cooling or no fan cooling which dissipate the same amount of heat regardless of speed.
- 1 = For 2 or 4-pole motors which generally have better cooling due to their higher speeds. The inverter assumes that the motor can dissipate full power at 50% nominal frequency.
- 2 = Suitable for special motors not continuously rated at nominal current at nominal frequency..
- 3 = For 6 or 8-pole motors. The inverter assumes that the motor can dissipate full power at nominal frequency.
- 4 = As P074 = 0 but the inverter trips (F074) instead of reducing the motor torque / speed.
- 5 = As P074 = 1 but the inverter trips (F074) instead of reducing the motor torque / speed.
- 6 = As P074 = 2 but the inverter trips (F074) instead of reducing the motor torque / speed.
- 7 = As P074 = 3 but the inverter trips (F074) instead of reducing the motor torque / speed.

Note: I²t motor protection is not recommended where the motor is less than half the power rating of the inverter.

P075 • Braking chopper enable (MMV only)
 Range: 0 - 1 [0]

- 0 = An external braking resistor is not connected.
- 1 = An external braking resistor is connected.

An external braking resistor can be used to 'dump' the power generated by the motor, thus giving greatly improved braking and deceleration capabilities. It **MUST** be greater than 40Ω (80Ω for 3 AC 400 V inverters) or the inverter will be damaged. Purpose made resistors are available to cater for all MICROMASTER Vector variants.

WARNING: Take care if an alternative resistor is to be used as the pulsed voltage applied by the inverter can destroy ordinary resistors.

Parameter	Function	Range [Default]	Description / Notes
-----------	----------	-----------------	---------------------

P076 • Pulse frequency

0 - 7
[0 or 4]

Sets the pulse frequency (from 2 to 16 kHz) and the PWM mode. If silent operation is not absolutely necessary, the losses in the inverter as well as the RFI emissions can be reduced by selecting lower pulse frequencies.

0/1 = 16 kHz (230 V default)
2/3 = 8 kHz
4/5 = 4 kHz (400 V default)
6/7 = 2 kHz

Even numbers = normal modulation technique.
Odd numbers = lower loss modulation technique used when operating mainly at speeds above 5 Hz.

As a result of the higher losses at higher pulse frequencies than those set in the factory, the maximum continuous output current is reduced as a function of the pulse frequency. If values 4, 5, 6 or 7 are selected for P076, then the drive inverters are not de-rated. The power de-rating is also valid for MMVXXX/3F with integrated filter. For MIDIMASTER Vector drive converters with 230V from 30kW upwards, 400V from 45kW upwards, and 575V from 22kW upwards, P076 can only be set to values 4, 5, 6 or 7 (4kHz or 2kHz). The pulse frequency is automatically reduced if the internal drive inverter monitoring functions determine an excessive heatsink temperature. The frequency is automatically increased again when the temperature has returned to a normal value.

Table to reduce the rated output current for higher pulse frequencies

Model	% of full load de-rating	
	P076 =0 or 1	P076 =2 or 3
MMV75/3	80	100
MMV110/3	50	80
MMV150/3	50	80
MMV220/3	80	100
MMV300/3	50	80
MMV400/3	50	80
MMV550/3	50	80
MMV750/3	50	80

Model	% of full load de-rating	
	P076 =0 or 1	P076 =2 or 3
MDV550/2	55	90
MDV750/2	64	90
MDV1100/2	55	75
MDV1500/2	47	80
MDV1850/2	43	79
MDV2200/2	38	68
MDV750/3	57	90
MDV1100/3	50	83
MDV1500/3	64	90
MDV1850/3	55	75
MDV2200/3	50	90
MDV3000/3	47	88
MDV3700/3	40	75
MDV550/4	75	100
MDV750/4	55	100
MDV1100/4	39	75
MDV1500/4	64	90
MDV1850/4	55	75

Parameter	Function	Range [Default]	Description / Notes
P077	Control mode	0 - 3 (1)	<p>Controls the relationship between the speed of the motor and the voltage supplied by the inverter. One of four modes can be selected:</p> <p>0 = V/f curve hp x 746 1 = FCC control 1.732 x efficiency x nom. volts x nom. amps 2 = Quadratic V/f 3 = Vector Control</p> <p>Note: When Sensorless Vector Control is selected (P077 = 3), P088 will automatically be set to 1, so that on first run-up, the inverter will measure the stator resistance of the motor and calculate motor constants from the rating plate data in P080 to P085.</p>
P078	<ul style="list-style-type: none"> Continuous boost (%) MMV MDV (P077=3) MDV (P077=0, 1 or 2) 	0 - 250 [100] [100] [50]	<p>For many applications it is necessary to increase low frequency torque. This parameter sets the start-up current at 0 Hz to adjust the available torque for low frequency operation. 100% setting will produce rated motor current (P083) at low frequencies.</p> <p>WARNING: If P078 is set too high, overheating of the motor and/or an overcurrent trip (F002) can occur.</p>
P079	Starting boost (%)	0 - 250 [0]	<p>For drives which require a high initial starting torque, it is possible to set an additional current (added to the setting in P078) during ramp duration (P002). This is only effective during initial start up and until the frequency setpoint is reached.</p> <p>WARNING: This increase is in addition to P078, but the total is limited to 250%.</p>
P080	Nominal rating plate motor power factor (cosφ)	0.00-1.00 [☆☆☆]	<p>If efficiency is shown on the motor rating plate, calculate the power factor as follows: pf =</p> <p>If neither power factor nor efficiency are shown on the motor rating plate - set P080 = 0.</p> <p>Notes:</p> <ol style="list-style-type: none"> These parameters P080 to P085 must be set for the particular motor used. Read the figures from the motor rating plate (see Figure 4.2..1). It will be necessary to perform an automatic calibration (P088 = 1) if P080 to P085 are changed from their factory default settings. When the inverter is set-up for North American operation (P101=1); P081 will default to 60Hz and P085 will indicate hp (0.16 - 250)
P081	Nominal rating plate frequency for motor (Hz)	0 - 650.00 [50.00]	
P082	Nominal rating plate speed for motor (RPM)	0 - 9999 [☆☆☆]	
P083	Nominal rating plate current for motor (A)	0.1-300.0 [☆☆☆]	
P084	Nominal rating plate voltage for motor (V)	0 - 1000 [☆☆☆]	
P085	Nominal rating plate power for motor (kW)	0.12-250.00 [☆☆☆]	
P086	Motor current limit (%)	0 - 250 [150]	<p>Defines the motor overload current as a % of the Nominal motor current (P083) allowed for up to one minute.</p> <p>With this parameter and P186, the motor current can be limited and overheating of the motor prevented. If the value set in P083 is exceeded for one minute, (or longer if the overload is small), the output frequency is reduced until the current falls to that set in P083. The inverter display flashes as a warning indication but the inverter does not trip. The inverter can be made to trip using P074.</p> <p>Note: The maximum value that P086 can be set to is automatically limited by the rating of the inverter. Further, the power can be automatically reduced for pulse frequencies which differ from the factory setting (refer to P076)</p>
P087	Motor PTC enable	0 - 1 [0]	<p>0 = Disabled 1 = External PTC enabled</p> <p>Note: If motor thermal protection is required, then an external PTC must be used and P087 = 1. If P087 = 1 and the PTC input goes high then the inverter will trip (fault code F004 displayed).</p>

Parameter	Function	Range [Default]	Description / Notes
P088	Automatic calibration	0 - 1 [0]	The motor stator resistance is used in the inverter's internal current monitoring calculations. When P088 is set to '1' and the RUN button is pressed, the inverter performs an automatic measurement of motor stator resistance; stores it in P089 and then resets P088 to '0'. If the measured resistance is too high for the size of inverter (e.g. motor not connected or unusually small motor connected), the inverter will trip (fault code F188) and will leave P088 set to '1'. If this happens, set P089 manually and then set P088 to '0'.
P089	● Stator resistance (Ω)	0.01-199.99 [☆☆☆☆]	Can be used instead of P088 to set the motor stator resistance manually. The value entered should be the resistance measured across any two motor phases. WARNING: The measurement should be made at the inverter terminals with power off and cold motor. Note: If the value of P089 is too high then an overcurrent trip(F002) may occur.
P091	● Serial link slave address	0 - 30 [0]	Up to 31 inverters can be connected via the serial link and controlled by a computer or PLC using the USS serial bus protocol. This parameter sets a unique address for the inverter.
P092	● Serial link baud rate	3 - 7 [6]	Sets the baud rate of the RS485 serial interface (USS protocol): 3 = 1200 baud 4 = 2400 baud 5 = 4800 baud 6 = 9600 baud 7 = 19200 baud Note: Some RS232 to RS485 converters are not capable of baud rates higher than 4800.
P093	● Serial line time-out (seconds)	0 - 240. [0]	This is the maximum permissible period between two incoming data telegrams. This feature is used to turn off the inverter in the event of a communications failure. Timing starts after a valid data telegram has been received and if a further data telegram is not received within the specified time period, the inverter will trip and display fault code F008. Setting the value to zero switches off the control.
P094	● Serial link nominal system setpoint (Hz)	0 - 650.00 [50.00]	Setpoints are transmitted to the inverter via the serial link as percentages. The value entered in this parameter represents 100% (HSW = 4000H).
P095	● USS compatibility	0 - 2 [0]	0 = Compatible with 0.1 Hz resolution 1 = Enable 0.01 Hz resolution 2 = HSW is not scaled but represents the actual frequency value to a resolution of 0.01 Hz (e.g. 5000 = 50 Hz).
P099	● Option module type	0 - 2 [0]	0 = Option module not present 1 = PROFIBUS module (enables parameters relating to PROFIBUS) 2 = CANbus module (enables parameters relating to CANbus)
P101	● Operation for Europe or North America	0 - 1 [0]	This sets the inverter for European or North America supply and nominal rating plate frequency for the motor to: 0 = Europe (50 Hz and power ratings to kW) 1 = North America (60 Hz and power ratings to hp) Note: After setting P101 =1 the inverter must be re-set to factory defaults, i.e. P944 = 1 to automatically set P013 = 60Hz, P081= 60Hz, P082 = 1680rpm P085 will be displayed in hp.
P111	Inverter power rating (kW/hp)	0.12- 75.00 [☆☆☆☆]	Read-only parameter that indicates the power rating of the inverter in kW. e.g. 0.55 = 550 W Note: If P101 = 1 then the rating is displayed in hp.

Parameter	Function	Range [Default]	Description / Notes																																																																																																
P112	Inverter type	1 - 8 [☆☆☆]	Read-only parameter. 1 = MICROMASTER 2nd Generation (MM2) 2 = COMBI MASTER 3 = MIDIMASTER 4 = MICROMASTER Junior (MMJ) 5 = MICROMASTER 3rd Generation (MM3) 6 = MICROMASTER Vector (MMV) 7 = MIDIMASTER Vector (MDV) 8 = COMBIMASTER 2nd Generation.																																																																																																
P113	Drive model	0 - 29 [☆☆☆]	Read-only parameter; indicates the Vector model number according to the type range indicated by P112.																																																																																																
			<table border="1"> <thead> <tr> <th>P113</th> <th>P112 = 6</th> <th>P112 = 7</th> <th>P113</th> <th>P112 = 6</th> <th>P112 = 7</th> </tr> </thead> <tbody> <tr><td>0</td><td>MMV12</td><td>MDV550/2</td><td>15</td><td>MMV110/2</td><td>MDV3000/3</td></tr> <tr><td>1</td><td>MMV25</td><td>MDV750/2</td><td>16</td><td>MMV150/2</td><td>MDV3700/3</td></tr> <tr><td>2</td><td>MMV37</td><td>MDV1100/2</td><td>17</td><td>MMV220/2</td><td>MDV4500/3</td></tr> <tr><td>3</td><td>MMV55</td><td>MDV1500/2</td><td>18</td><td>MMV300/2</td><td>MDV5500/3</td></tr> <tr><td>4</td><td>MMV75</td><td>MDV1850/2</td><td>19</td><td>MMV400/2</td><td>MDV7500/3</td></tr> <tr><td>5</td><td>MMV110</td><td>MDV2200/2</td><td>20</td><td>MMV37/3</td><td>MDV220/4</td></tr> <tr><td>6</td><td>MMV150</td><td>MDV3000/2</td><td>21</td><td>MMV55/3</td><td>MDV400/4</td></tr> <tr><td>7</td><td>MMV220</td><td>MDV3700/2</td><td>22</td><td>MMV75/3</td><td>MDV550/4</td></tr> <tr><td>8</td><td>MMV300</td><td>MDV4500/2</td><td>23</td><td>MMV110/3</td><td>MDV750/4</td></tr> <tr><td></td><td></td><td></td><td>24</td><td>MMV150/3</td><td>MDV1100/4</td></tr> <tr><td>10</td><td>MMV12/2</td><td>MDV750/3</td><td>25</td><td>MMV220/3</td><td>MDV1500/4</td></tr> <tr><td>11</td><td>MMV25/2</td><td>MDV1100/3</td><td>26</td><td>MMV300/3</td><td>MDV1850/4</td></tr> <tr><td>12</td><td>MMV37/2</td><td>MDV1500/3</td><td>27</td><td>MMV400/3</td><td>MDV2200/4</td></tr> <tr><td>13</td><td>MMV55/2</td><td>MDV1850/3</td><td>28</td><td>MMV550/3</td><td>MDV3000/4</td></tr> <tr><td>14</td><td>MMV75/2</td><td>MDV2200/3</td><td>29</td><td>MMV750/3</td><td>MDV3700/4</td></tr> </tbody> </table>	P113	P112 = 6	P112 = 7	P113	P112 = 6	P112 = 7	0	MMV12	MDV550/2	15	MMV110/2	MDV3000/3	1	MMV25	MDV750/2	16	MMV150/2	MDV3700/3	2	MMV37	MDV1100/2	17	MMV220/2	MDV4500/3	3	MMV55	MDV1500/2	18	MMV300/2	MDV5500/3	4	MMV75	MDV1850/2	19	MMV400/2	MDV7500/3	5	MMV110	MDV2200/2	20	MMV37/3	MDV220/4	6	MMV150	MDV3000/2	21	MMV55/3	MDV400/4	7	MMV220	MDV3700/2	22	MMV75/3	MDV550/4	8	MMV300	MDV4500/2	23	MMV110/3	MDV750/4				24	MMV150/3	MDV1100/4	10	MMV12/2	MDV750/3	25	MMV220/3	MDV1500/4	11	MMV25/2	MDV1100/3	26	MMV300/3	MDV1850/4	12	MMV37/2	MDV1500/3	27	MMV400/3	MDV2200/4	13	MMV55/2	MDV1850/3	28	MMV550/3	MDV3000/4	14	MMV75/2	MDV2200/3	29	MMV750/3	MDV3700/4
P113	P112 = 6	P112 = 7	P113	P112 = 6	P112 = 7																																																																																														
0	MMV12	MDV550/2	15	MMV110/2	MDV3000/3																																																																																														
1	MMV25	MDV750/2	16	MMV150/2	MDV3700/3																																																																																														
2	MMV37	MDV1100/2	17	MMV220/2	MDV4500/3																																																																																														
3	MMV55	MDV1500/2	18	MMV300/2	MDV5500/3																																																																																														
4	MMV75	MDV1850/2	19	MMV400/2	MDV7500/3																																																																																														
5	MMV110	MDV2200/2	20	MMV37/3	MDV220/4																																																																																														
6	MMV150	MDV3000/2	21	MMV55/3	MDV400/4																																																																																														
7	MMV220	MDV3700/2	22	MMV75/3	MDV550/4																																																																																														
8	MMV300	MDV4500/2	23	MMV110/3	MDV750/4																																																																																														
			24	MMV150/3	MDV1100/4																																																																																														
10	MMV12/2	MDV750/3	25	MMV220/3	MDV1500/4																																																																																														
11	MMV25/2	MDV1100/3	26	MMV300/3	MDV1850/4																																																																																														
12	MMV37/2	MDV1500/3	27	MMV400/3	MDV2200/4																																																																																														
13	MMV55/2	MDV1850/3	28	MMV550/3	MDV3000/4																																																																																														
14	MMV75/2	MDV2200/3	29	MMV750/3	MDV3700/4																																																																																														
P121	Enable/disable RUN button	0 - 1 [1]	0 = RUN button disabled 1 = RUN button enabled (only possible if P007 = 1)																																																																																																
P122	Enable/disable FORWARD/REVERSE button	0 - 1 [1]	0 = FORWARD/REVERSE button disabled 1 = FORWARD/REVERSE button enabled (only possible if P007 = 1)																																																																																																
P123	Enable/disable JOG button	0 - 1 [1]	0 = JOG button disabled 1 = JOG button enabled (only possible if P007 = 1)																																																																																																
P124	Enable/disable Δ and ∇ buttons	0 - 1 [1]	0 = Δ and ∇ buttons disabled 1 = Δ and ∇ buttons enabled (only possible if P007 = 1) Note: This applies for frequency adjustment only. The buttons can still be used to change parameter values.																																																																																																
P125	Reverse direction inhibit	0 - 1 [1]	This parameter can be used to prevent the inverter from running a motor in the reverse direction. 0 = Reverse direction disabled. Inhibits reverse commands from ALL sources (e.g. front panel, digital, analogue, etc.). All negative RUN commands (e.g. ON left, JOG left, REVERSE, etc.) result in FORWARD rotation. Any negative result of setpoint addition is clipped at 0 Hz. 1 = Normal operation. Forward and reverse direction of rotation allowed.																																																																																																
P128	Fan switch-off delay time (seconds) (MMV only)	0 - 600 [120]	Time taken for the fan to switch off following an OFF command.																																																																																																
P131	Frequency setpoint (Hz)	0.00-650.00 [-]	Read-only parameters. These are copies of the values stored in P001 but can be accessed directly via the serial link.																																																																																																
P132	Motor current (A)	0.0 - 300.0 [-]																																																																																																	
P133	Motor torque (% nominal torque)	0 - 250 [-]																																																																																																	
P134	DC link voltage (V)	0 - 1000 [-]																																																																																																	

Parameter	Function	Range [Default]	Description / Notes
P135	Motor RPM	0 - 9999 [-]	
P137	Output voltage (V)	0 - 1000 [-]	
P138	Instantaneous rotor / shaft frequency (Hz)(Vector mode only)	0 - 650 [-]	
P139	Peak output current detect	0.0 - 99.9 [-]	Stores the peak current seen by the motor. Can be reset using Δ and ∇ buttons.
P140	Most recent fault code	0 - 255 [-]	Read only. The last recorded fault code (see section 7) is stored in this parameter. The stored value can be cleared by using the Δ and ∇ buttons. Or by resetting to factory defaults (P944) This is a copy of the code stored in P930.
P141	Most recent fault code -1	0 - 255 [-]	Read only. This parameter stores the last recorded fault code prior to that stored in P140/P930.
P142	Most recent fault code -2	0 - 255 [-]	Read only. This parameter stores the last recorded fault code prior to that stored in P141.
P143	Most recent fault code -3	0 - 255 [-]	Read only. This parameter stores the last recorded fault code prior to that stored in P142.
P186 ●	Motor instantaneous current limit (%)	0 - 500* (200)	This parameter defines the instantaneous motor current limit as a % of the nominal motor current (P083). If the output current reaches this limit for three seconds, the inverter automatically reduces the current to the limit set in P086. Note: * The maximum value that can be set for P186 is automatically limited by the rating of the inverter. Torque limit operation is available, from 5Hz to 50Hz, when using Vector Control mode (P077=3). The motor torque produced is a function of motor current. If P186 and P086 are equal, the current limit function can effectively be used as a torque limit.
P201	PID closed loop mode	0 - 1 [0]	0 = Normal operation (closed loop process control disabled). 1 = Closed loop process control using analogue input 2 as feedback.
P202 ●	P gain	0.0-999.9 [1.0]	Proportional gain.
P203 ●	I gain	0.00-99.9 [0]	Integral gain. 0.01% corresponds to the longest integral action time.
P204 ●	D gain	0.0-999.9 [0]	Derivative gain.
P205 ●	Sample interval (x 25 ms)	1 - 2400 [1]	Sampling interval of feedback sensor. The integral response rate is slowed down by this factor
P206 ●	Transducer filtering	0 - 255 [0]	0 = Filter off. 1 - 255 = Low pass filtering applied to transducer.
P207 ●	Integral capture range (%)	0 - 100 [100]	Percentage error above which integral term is reset to zero.
P208	Transducer type	0 - 1 [0]	0 = An increase in motor speed causes an increase in transducer voltage/current output. 1 = An increase in motor speed causes a decrease in transducer voltage/current output..
P210	Transducer reading (%)	0.00-100.00 [-]	Read-only. Value is a percentage of full scale of the selected signal input (i.e. 10 V or 20 mA).
P211 ●	0% setpoint	0.0 - 100.00 [0.0]	Value of P210 to be maintained for 0% setpoint.
P212 ●	100% setpoint	0.0 - 100.00 [100.00]	Value of P210 to be maintained for 100% setpoint.

Parameter	Function	Range [Default]	Description / Notes
P220	Frequency cut-off.	0 - 1 [0]	<p>0 = Normal operation. 1 = Switch off inverter output at or below minimum frequency.</p> <p>Note: Active in all modes.</p>
P321	● Minimum analogue frequency for analogue setpoint 2 (Hz)	0 - 650.00 [0.00]	Frequency corresponding to the lowest analogue input value, i.e. 0 V/0 mA or 2 V/4 mA, determined by P323 and the settings of the DIP selector switches 4 and 5 (see Section 4.1.2). This can be set to a higher value than P322 to give an inverse relationship between analogue input and frequency output (see diagram in P322).
P322	● Maximum analogue frequency for analogue setpoint 2 (Hz)	0 - 650.00 [50.00]	Frequency corresponding to the highest analogue input value, i.e. 10 V or 20 mA, determined by P323 and the setting of the DIP selector switches 4 and 5 (see Section 4.1.2).. This can be set to a lower value than P321 to give an inverse relationship between analogue input and frequency output.
P323	● Analogue input 2 type	0 - 2 [0]	<p>Sets analogue input type for analogue input 2, in conjunction with the settings of the DIP selector switches 4 and 5 (see, Section 4.1.2) :</p> <p>0 = 0 V to 10 V/ 0 to 20 mA Unipolar input 1 = 2 V to 10 V/ 4 to 20 mA Unipolar input 2 = 2 V to 10 V/ 4 to 20 mA Unipolar input with controlled start / stop when using analogue input control.</p> <p>Note: Setting P323 = 2 will not work unless the inverter is under full local control (i.e. P910 = 0 or 4) and $V \geq 1$ V or 2mA.</p> <p>WARNING: The inverter will automatically start when voltage goes above 1V or 2mA. This equally applies to both analogue and digital control (i.e. P006 = 0 or 1)</p>
P356	Digital input 6 configuration	0 - 24 [6]	Control function selection, DIN 6 See P051 - P055 for description.
P386	Sensorless vector speed control loop gain - proportional term	0.1 - 20.0 [1.0]	<p>To optimise the dynamic performance of the vector control this parameter should be incremented whilst the inverter is operating under typical conditions until the first signs of speed instability occur. The setting should then be reduced slightly (approx. 10%) until stability is restored. In general, the optimum setting required will be proportional to the load inertia. If this setting is too low or too high, rapid load changes may result in DC link overvoltage trips (F001) and/or unstable vector control.</p> <p>See section 5.3.3 for further information .</p> <p>Note: P386 = $\frac{\text{Load inertia} + \text{motor shaft inertia}}{\text{motor shaft inertia}}$</p>
P387	Sensorless vector speed control loop gain - integral term	0.01- 10.0 [1.0]	<p>P386 must be optimised before adjusting P387. Whilst operating the inverter under typical conditions, increment this parameter until the first signs of speed instability occur. The setting should then be reduced slightly (approx. 30%) until stability is restored.</p> <p>See section 5.3.3 for further information.</p>
P700			Specific to PROFIBUS-DP. See PROFIBUS Handbook for further details. Access only possible with P099 = 1
P701	●		
P702			

Parameter	Function	Range [Default]	Description / Notes
P720 ●	Direct input/output functions	0 - 7 [0]	Allows direct access to the relay outputs and the analogue output via the serial link (USS or PROFIBUS-DP with module): <ul style="list-style-type: none"> 0 = Normal operation 1 = Direct control of relay 1 2 = Direct control of relay 2 3 = Direct control of relay 1 and relay 2 4 = Direct control of analogue output 1 only 5 = Direct control of analogue output 1 and relay 1 6 = Direct control of analogue output 1 and relay 2 7 = Direct control of analogue output 1, relay 1 and relay 2
P721	Analogue input 1 voltage (V)	0.0 - 10.0 [-]	Read only. Displays the analogue input 1 voltage (approximate).
P722 ●	Analogue output 1 current (mA)	0.0 - 20.0 [0.0]	Allows direct control of the output current over the serial link if P720 = 4, 5, 6 or 7.
P723	State of digital inputs	0 - 3F [-]	Read-only. Provides a HEX representation of a 6-digit binary number of which the LSB = DIN1 and the MSB = DIN6 (1 = ON, 0 = OFF). e.g. If P723 = B, this represents '001011' - DIN1, DIN2 and DIN4 = ON, DIN3, DIN5 and DIN6 = OFF.
P724 ●	Relay output control	0 - 3 [0]	Enables control of the output relays. Used in conjunction with P720, e.g. setting P724 = 1 (relay 1 = ON) has no effect unless P720 = 1, 3, 5, or 7. <ul style="list-style-type: none"> 0 = Both relays OFF / de-energised 1 = Relay 1 ON / energised 2 = Relay 2 ON / energised 3 = Both relays ON / energised
P725	Analogue input 2 voltage (V)	0.0-10.0 [-]	Read only. Displays the analogue input 2 voltage (approximate) only when analogue input 2 is active (P051 to P055 or P356 = 24 and the respective digital input is high).
P726	Analogue output 2 current (mA) (MDV only)	0.0-20.0 [0.0]	Allows direct control of the analogue output 2 current over the serial link if P720 = 4, 5, 6 or 7.
P880			Specific to PROFIBUS-DP. See PROFIBUS Handbook for further details. Access only possible with P099 = 1
P900 to P970	(Other than those listed below)		<i>Specific to PROFIBUS-DP and CANbus operation. See PROFIBUS or CANbus Handbook for further details.</i> <i>Access only possible with P099 = 1 or 2</i>
P910 ●	Local / USS mode	0 - 4 [0]	Sets the inverter for local control or USS control over the serial link: <ul style="list-style-type: none"> 0 = Local control 1 = USS control (and setting of parameter values) 2 = Local control (but USS control of frequency) 3 = USS control (but local control of frequency) 4 = Local control (but USS read and write access to parameters and facility to reset trips) <p>Note: When operating the inverter via USS control (P910 = 1 or 2), the analogue input remains active when P006 = 1 and is added to the setpoint.</p>
P922	Software version	0.00 - 99.99 [-]	Contains the software version number and cannot be changed.
P923 ●	Equipment system number	0 - 255 [0]	You can use this parameter to allocate a unique reference number to the inverter. It has no operational effect.
P930	Most recent fault code	0 - 255 [-]	See Parameter 140
P931	Most recent warning type	0 - 99 [-]	Read only. The last recorded warning is stored in this parameter until power is removed from the inverter. This can be cleared by using the Δ and ∇ buttons.

See section 7.2 for explanation of warning codes

Parameter	Function	Range [Default]	Description / Notes
P944	Reset to factory default settings	0 - 1 [0]	Set to '1' and then press P to reset all parameters except P101 to the factory default settings. Previously set parameters will be overwritten including the motor parameters P080 - P085 (See section 4.2)
P971 ●	EEPROM storage control	0 - 1 [1]	<p>0 = Changes to parameter settings (including P971) are lost when power is removed.</p> <p>1 = Changes to parameter settings are retained during periods when power is removed.</p> <p>IMPORTANT: When using the serial link to update the parameter set held in EEPROM, care must be taken not to exceed the maximum number of write cycles to this EEPROM - this is approximately 50,000 write cycles. Exceeding this number of write cycles would result in corruption of the stored data and subsequent data loss. The number of read cycles are unlimited.</p>

7. FAULT AND WARNING CODES

7.1 Fault Codes

In the event of a fault, the inverter switches off and a fault code appears on the display. The last fault that occurred is stored in parameter P140, the preceding faults in P141 - P143.. e.g. '0004' indicates that the last fault was F004

Fault Code	Cause	Corrective Action
F001	Overvoltage	Check whether supply voltage is within the limits indicated on the rating plate. Increase the Ramp-down time (P003) or apply braking resistor (option). Check whether the required braking power is within the specified limits.
F002	Overcurrent	Check whether the motor power corresponds to the inverter power. Check that the cable length limits have not been exceeded. Check motor cable and motor for short-circuits and earth faults. Check whether the motor parameters (P080 - P085) correspond with the motor being used. Check the stator resistance (P089). Increase the ramp-up time (P002). Reduce the boost set in P078 and P079. Check whether the motor is obstructed or overloaded.
F003	Overload	Check whether the motor is overloaded. Increase the maximum motor frequency if a motor with high slip is used.
F004	Overheating of motor (monitoring with PTC)	Check if motor is overloaded. Check the connections to the PTC. Check that P087 has not been set to 1 without a PTC being connected.
F005	Inverter overtemperature (internal heatsink sensor)	Check that the ambient temperature is not too high. Check that the air inlet and outlet are not obstructed. Check that the inverter's integral fan is working
F008	USS protocol time-out	Check the serial interface. Check the settings of the bus master and P091 - P093. Check whether the time-out interval is too short (P093).
F009	Undervoltage	Check whether the supply voltage is within the limits indicated on the rating plate. Check the supply is not subject to temporary failures or voltage reductions.
F010	Initialisation fault	Check the entire parameter set. Set P009 to '0000' before power down.
F011	Internal interface fault ¹	Switch off power and switch on again.
F012	External trip	Source of trip is digital input (configured as an external trip input) going low - check the external source.
F013	Programme fault ¹	Switch off power and switch on again.
F016	Sensorless vector control unstable	Try calibrating the stator resistance (set P088 to 1 and RUN). Alternatively try re-adjusting the sensorless vector control loop gain (see P386).
F030	PROFIBUS link failure	Check the integrity of the link.
F031	PROFIBUS to inverter link failure	Check the integrity of the link.
F033	PROFIBUS configuration error	Check the PROFIBUS configuration.
F036	PROFIBUS module watchdog trip	Replace PROFIBUS module
F057	Delayed Trip (See P057)	P051 to P055 or P356 = 20 and trip input has remained low for longer than the time set in P057
F074	Motor overtemperature by I ² t calculation	Trip occurs only if P074 = 4, 5, 6 or 7. Check that the motor current does not exceed the value set in P083 and P086.
F075	Over current during ramping down	Increase the ramp down time (P003).
F101	Internal interface fault ¹	Switch off power and switch on again.
F105	Inverter overtemperature (internal sensor)	Check that the ambient temperature is not too high. Check that the air inlet and outlet are not obstructed Check that the inverter's integral fan is working

Fault Code	Cause	Corrective Action
F106	Parameter fault P006	Parameterise fixed frequency(ies) on the digital inputs.
F112	Parameter fault P012/P013	Set parameter P012 < P013.
F151- F156	Digital input parameter fault	Change the settings of digital inputs P051 to P055 and P356.
F188	Automatic calibration failure	Motor not connected to inverter - connect motor. If the fault persists, set P088 = 0 and then enter the measured stator resistance of the motor into P089 manually.
F201	P006 = 1 while P201 = 2	Change parameter P006 and / or P201
F212	Parameter fault P211/P212	Set parameter P211 < P212.
F231	Output current measurement imbalance	See F002
F255	Watchdog Trip	Remove prime power and re-apply

¹ Ensure that the wiring guidelines described in section 1.2 have been complied with.

When the fault has been corrected the inverter can be reset. To do this press button **P** twice (once to display P000 and the second time to reset the fault), or clear the fault via a binary input (see parameters P051 - P055 and P356 in section 6).

7.2 Warning Codes

In the event of a warning, the inverter display will flash. The last warning to occur is stored in parameter P931.

Warning Code	Cause	Corrective Action
002	Current limit active	Check whether the motor power corresponds to the inverter power. Check that the cable length limits have not been exceeded. Check motor cable and motor for short-circuits and earth faults. Check whether the motor parameters (P080 - P085) correspond with the motor being used. Check the stator resistance (P089). Increase the ramp-up time (P002). Reduce the boost set in P078 and P079. Check whether the motor is obstructed or overloaded.
003	Voltage limit active	Increase ramp time or fit breaking resistor
004	Slip limit exceeded	Check that motor is not overloaded, check motor parameters
005	Inverter overtemperature (heatsink)	Check that the ambient temperature is not too high. Check that the air inlet and outlet are not obstructed. Check that the inverter's integral fan is working
006	Motor over-temperature	Check if motor is overloaded. Check that P087 has not been set to 1 without a PTC being connected.
010	15V power supply - current limit	Check Connections
018	Auto re-start after fault (P018) is pending	WARNING: The inverter may start at any time.
075	Braking resistor - hot	

8. SPECIFICATIONS

230V Single Phase MICROMASTER Vector Inverters									
Order No.(with built-in filter class A (6SE32)).	10-7BA40	11-5BA40	12-1BA40	12-8BA40	13-6BA40	15-2BB40	16-8BB40	21-0BC40	21-3BC40
Inverter model	MMV12	MMV25	MMV37	MMV55	MMV75	MMV110	MMV150	MMV220	MMV300 ^c
Input voltage range	1 AC 208V - 240 V +/-10%								
Motor output rating ^a (kW/hp)	0.12/ 1/6	0.25/ 1/3	0.37/1/2	0.55/3/4	0.75/ 1	1.1 / 1 1/2	1.5 / 2	2.2 / 3	3.0/ 4
Continuous output @ 230V	350VA	660 VA	880 VA	1.14 kVA	1.5 kVA	2.1 kVA	2.8 kVA	4.0 kVA	5.2kVA
Output current (nom.) (A) ^a	0.75	1.5	2.1	2.6	3.5	4.8	6.6	9.0	11.8
Output current (max. continuous) (A)	0.9	1.7	2.3	3.0	3.9	5.5	7.4	10.4	13.6
Input current (max.) (A)	1.8	3.2	4.6	6.2	8.2	11.0	14.4	20.2	28.3
Recommended mains fuse(A)	10			16		20		25	30
Fuse order code	3NA3803			3NA3805		3NA3807		3NA3810	3NA3814
Recommended lead cross-section (min.)	Input 1.0 mm ²			1.5 mm ²		2.5 mm ²		4.0 mm ²	
	Output 1.0 mm ²			1.5 mm ²		1.5 mm ²		2.5 mm ²	
Dimensions (mm) (w x h x d)	73 x 175 x 141					149 x 184 x 172		185 x 215 x 195	
Weight (kg / lb)	0.85 / 1.9					2.6 / 5.7		5.0 / 11.0	

All 1 AC 230 V MICROMASTER Vector include integrated Class A filters. Optional external Class B filters are available (see section 9.3).

230 V 1/3 AC MICROMASTER Vector Inverters										
Order No. (6SE32..)	10-7CA40	11-5CA40	12-1CA40	12-8CA40	13-6CA40	15-2CB40	16-8CB40	21-0CC40	21-3CC40	21-8CC40
Inverter model	MMV122	MMV252	MMV372	MMV552	MMV752	MMV1102	MMV1502	MMV2202	MMV3002 ^c	MMV4002
Input voltage range	1 - 3 AC 208V - 240 V +/-10%									
Motor output rating ^a (kW/hp)	0.12/ 1/6	0.25/ 1/3	0.37/1/2	0.55/3/4	0.75/ 1	1.1 / 1 1/2	1.5 / 2	2.2 / 3	3.0 / 4	4.0 / 5
Continuous output @ 230V	480VA	660 VA	880 VA	1.14 kVA	1.5 kVA	2.1 kVA	2.8 kVA	4.0 kVA	5.2 kVA	7.0kVA
Output current (nom.) (A) ^a	0.8	1.5	2.1	2.6	3.5	4.8	6.6	9.0	11.8	15.9
Output current (max. continuous) (A)	0.9	1.7	2.3	3.0	3.9	5.5	7.4	10.4	13.6	17.5
Input current (I rms) (1 AC / 3 AC)	1.8/1.1A	3.2/1.9A	4.6/2.7A	6.2/3.6A	8.2/4.7A	11.0/6.4 A	14.4/8.3 A	20.2/11.7A	28.3/16.3 A	-/21.1 A
Recommended mains fuse(A) ^b	10			16		20	25	30	30	25
Fuse order code	3NA3803			3NA3805		3NA3807	3NA3810	3NA3814	3NA3810	
Recommended lead cross-section (min.)	Input 1.0 mm ²			1.5 mm ²		2.5 mm ²		4.0 mm ²		
	Output 1.0 mm ²			1.5 mm ²		2.5 mm ²				
Dimensions (mm) (w x h x d)	73 x 175 x 141					149 x 184 x 172		185 x 215 x 195		
Weight (kg / lb)	0.75 / 1.7					2.4 / 5.3		4.8 / 10.5		

All 1 AC and 3 AC 230 V MICROMASTERS (excluding MMV400/2) are suitable for 208 V operation.

All 3 AC 230 V MICROMASTER Vector can operate on 1 AC 230 V (MMV300/2 requires an external line choke, e.g. 4EM6100-3CB).

380 V - 500 V Three Phase MICROMASTER Vector Inverters										
Order No. (6SE32..)	11-1DA40	11-4DA40	12-0DA40	12-7DA40	14-0DA40	15-8DB40	17-3DB40	21-0DC40	21-3DC40	21-5DC40
Inverter model	MMV37/3	MMV55/3	MMV75/3	MMV110/3	MMV150/3	MMV220/3	MMV300/3	MMV400/3	MMV550/3	MMV750/3
Input voltage range	3 AC 380 V - 500 V +/-10%									
Motor output rating ^a (kW/ hp)	0.37 /1/2	0.55 / 3/4	0.75 / 1	1.1 /1 1/2	1.5 / 2	2.2 / 3	3.0 / 4	4.0 / 5	5.5 / 7 1/2	7.5 / 10
Continuous output @ 400V ^a	930VA	1180VA	1530VA	2150VA	2.8 kVA	4.0 kVA	5.2 kVA	7.0 kVA	9.0 kVA	12.1 kVA
Output current (nom.) (A)	1.2	1.5	2.0	2.8	3.7	5.2	6.8	9.2	11.8	15.8
Output current (max. continuous) (A)*	1.2	1.6	2.1	3.0	4.0	5.9	7.7	10.2	13.2	17.5
Input current (max.) (A)	2.2	2.8	3.7	4.9	5.9	8.8	11.1	13.6	17.1	22.1
Recommended mains fuse(A)	10			16		20		25		
Fuse order code	3NA3803			3NA3805		3NA3807		3NA3810		
Recommended lead cross-section (min.)	Input 1.0 mm ²			1.5 mm ²		2.5 mm ²		4.0 mm ²		
	Output 1.0 mm ²			1.5 mm ²		2.5 mm ²		4.0 mm ²		
Dimensions (mm) (w x h x d)	73 x 175 x 141					149 x 184 x 172		185 x 215 x 195		
Weight (kg / lb)	0.75 / 1.7					2.4 / 5.3		4.8 / 10.5		

Optional external Class A and Class B filters are available (see section 9.3).

Notes:

^a Siemens 4 pole-motor, 1LA5 series or equivalent.

^b Assumes 3-phase supply. If a single phase supply is used, the input current ratings, wire sizes and fuses for single phase MICROMASTERS will apply.

^c MMV300 and MMV300/2 require an external choke (e.g. 4EM6100-3CB) and a 30 A mains fuse to operate on a single phase supply.

* Output current ratings are reduced by 10% when operating on mains supply voltages over 460V.

380 V - 480 V Three Phase MICROMASTER Vector Inverters with built-in Class A filter											
Order No. (6SE32..)						15-8DB50	17-3DB50	21-0DC50	21-3DC50	21-5DC50	
Inverter model						MMV220/3F	MMV300/3F	MMV400/3F	MMV550/3F	MMV750/3F	
Input voltage range	3 AC 380 V - 480 V +/-10%										
Motor output rating ^a (kW/ hp)						2.2 / 3	3.0 / 4	4.0 / 5	5.5 / 7½	7.5 / 10	
Continuous output @ 400V ^a						4.0 kVA	5.2 kVA	7.0 kVA	9.0 kVA	12.1 kVA	
Output current (nom.) (A)						5.2	6.8	9.2	11.8	15.8	
Output current (max. continuous) (A)*						5.9	7.7	10.2	13.2	17.0	
Input current (max.) (A)						8.8	11.1	13.6	17.1	22.1	
Recommended mains fuse(A)						16		20		25	
Fuse order code						3NA3805		3NA3807		3NA3810	
Recommended lead cross-section (min.)	Input					1.5 mm ²		2.5 mm ²			4.0 mm ²
	Output	1.0 mm ²					1.5 mm ²			2.5 mm ²	
Dimensions (mm) (w x h x d)						149 x 184 x 172			185 x 215 x 195		
Weight (kg / lb)						2.4 / 5.3			4.8 / 10.5		

Class B may be achieved by adding a Class B footprint filter to an unfiltered inverter

230 V Three Phase MIDIMASTER Vector Inverters													
Order No. - IP21 / NEMA 1 (6SE32..)	22-3CG40		23-1CG40		24-2CH40		25-4CH40		26-8CJ40		27-5CJ40		
Order No. - IP20 / NEMA 1 with integrated filter	22-3CG50		23-1CG50		24-2CH50		25-4CH50		26-8CJ50		27-5CJ50		
Order No. - IP56 / NEMA 4/12 (6SE32..)	22-3CS45		23-1CS45		24-2CS45		25-4CS45		26-8CS45		27-5CS45		
Inverter model	MDV550/2		MDV750/2		MDV1100/2		MDV1500/2		MDV1850/2		MDV2200/2		
Constant Torque (CT)	CT	VT	CT	VT	CT	VT	CT	VT	CT	VT	CT	VT	
Variable Torque (VT)													
Input voltage range	3 AC 208V - 240 V +/-10%												
Motor output rating (kW/hp)	5.5/ 7.5	7.5/ 10	7.5/ 10	11/ 15	11/ 15	-	15/ 20	18.5/25	18.5/25	22/ 30	22/ 30	30/ 40	
Continuous output (kVA) @230V	8.8	11.2	11.2	16.7	16.7	-	21.5	27.1	27.1	31.9	31.9	35.8	
Output current (max. continuous) (A)	22	28	28	42	42	-	54	68	68	80	80	95	
Input current (max.) (A)	32		45		61		75		87		100		
Recommended mains fuse (A)	50		63				80		100				
Fuse order code	3NA3820		3NA3822				3NA3824		3NA3830				
Recommended lead cross-section (mm ²)	Input (min.)	6		10		16	n/a	25		35			
	Output (min.)	4	6			10		n/a		16		25	35
Dimensions (mm) (w x h x d)	IP21 / NEMA 1	275 x 450 x 210		275 x 550 x 210				275 x 650 x 285					
	IP20 / NEMA 1 with integrated filter	275 x 700 x 210		275 x 800 x 210				275 x 920 x 285					
	IP56 / NEMA 4/12	360 x 675 x 351		360 x 775 x 422				360 x 875 x 483					
Weight (kg)	IP21 / NEMA 1	11.0		14.5		15.5		26.5		27.0		27.5	
	IP20 / NEMA 1 with integrated filter	18		22		23		37		38		38	
	IP56 / NEMA 4/12	30.5		38.0		40.0		50.5		52.5		54.5	

* Output current ratings are reduced by 10% when operating on mains supply voltages over 460V.

230 V Three Phase MIDIMASTER Vector Inverters						
Order No. - IP21 / NEMA 1 (6SE32..)	31-0CK40		31-3CK40		31-5CK40	
Order No. - IP20 / NEMA 1 with integrated filter	31-0CK50		31-3CK50		31-5CK50	
Order No. - IP56 / NEMA 4/12 (6SE32..)	31-0CS45		31-3CS45		31-5CS45	
Inverter model	MDV3000/2		MDV3700/2		MDV4500/2	
Constant Torque (CT)	CT	VT	CT	VT	CT	VT
Variable Torque (VT)						
Input voltage range	3 AC 208V - 240 V +/-10%					
Motor output rating (kW/hp)	30/ 40	37/ 50	37/ 50	45/ 60	45/ 60	-
Continuous output (kVA) @230V	41.4	51.8	51.8	61.3	61.3	-
Output current (max. continuous) (A)	104	130	130	154	154	-
Input current (max.) (A)	143		170		170	
Recommended mains fuse (A)	160		200			
Fuse order code	3NA3036		3NA3140			
Recommended lead	Input (min.)		70			
cross-section (mm ²)	Output (min.)		95			
	50	70	70	95		
Dimensions (mm)	IP21 / NEMA 1		420 x 850 x 310			
(w x h x d)	IP20 / NEMA 1 with integrated filter		420 x 1150 x 310			
	IP56 / NEMA 4/12		500 x 1150 x 570			
Weight (kg)	IP21 / NEMA 1		55.0		56.5	
	IP20 / NEMA 1 with integrated filter		85		87	
	IP56 / NEMA 4/12		80		90	

380 V - 500 V Three Phase MIDIMASTER Vector Inverters														
Order No. - IP21 / NEMA 1 (6SE32..)	21-7DG40		22-4DG40		23-0DH40		23-5DH40		24-2DJ40		25-5DJ40		26-8DJ40	
Order No. - IP20 / NEMA 1 with integrated filter	21-7DG50		22-4DG50		23-0DH50		23-5DH50		24-2DJ50		25-5DJ50		26-8DJ50	
Order No. - IP56 / NEMA 4/12 (6SE32..)	21-7DS45		22-4DS45		23-0DS45		23-5DS45		24-2DS45		25-5DS45		26-8DS45	
Inverter model	MDV750/3		MDV1100/3		MDV1500/3		MDV1850/3		MDV2200/3		MDV3000/3		MDV3700/3	
Constant Torque (CT) Variable Torque (VT)	CT	VT	CT	VT	CT	VT	CT	VT	CT	VT	CT	VT	CT	VT
Input voltage range	3 AC 380 V - 500 V +/-10%													
Motor output rating (kW/hp)	7.5/ 10	11/ 15	11/15	15/20	15/20	185/25	185/25	22/30	22/30	30/40	30/40	37/50	37/50	45/60
Continuous output (kVA) @400V	12. 7	16. 3	18	20.8	22.2	25.6	26.3	30.1	31.2	40.2	40.2	48.8	49.9	50.2
Output current (max. continuous) @ 400 V (A) *	19	23. 5	26	30	32	37	38	43.5	45	58	58	71	72	84
Input current (max.) (A)	30		32		41		49		64		79		96	
Recommended mains fuse (A)	32				50				80				100	
Fuse order code	3NA3814				3NA3820				3NA3824				3NA3830	
Recommended lead cross-section (mm ²)	Input (min.)	6		10		16		25		35				
	Output (min.)	4		6		10		16		25				
Dimensions (mm) (w x h x d)	IP21 / NEMA 1	275 x 450 x 210				275 x 550 x 210				275 x 650 x 285				
	IP20 / NEMA 1 with integrated filter	275 x 700 x 210				275 x 800 x 210				275 x 920 x 285				
	IP56 / NEMA 4/12	360 x 675 x 351				360 x 775 x 422				360 x 875 x 483				
Weight (kg)	IP21 / NEMA 1	11.5	12.0	16.0	17.0	27.5	28.0	28.5						
	IP20 / NEMA 1 with integrated filter	19	19	23	24	38	39	39						
	IP56 / NEMA 4/12	28.5	30.5	38	40	50.5	52.5	54.5						

380 V - 500 V Three Phase MIDIMASTER Vector Inverters						
Order No. - IP21 / NEMA 1 (6SE32..)	28-4DK40		31-0DK40		31-4DK40	
Order No. - IP20 / NEMA 1 with integrated filter	28-4DK50		31-0DK50		31-4DK50	
Order No. - IP56 / NEMA 4/12 (6SE32..)	28-4DS45		31-0DS45		31-4DS45	
Inverter model	MDV4500/3		MDV5500/3		MDV7500/3	
Constant Torque (CT) Variable Torque (VT)	CT	VT	CT	VT	CT	VT
Input voltage range	3 AC 380 V - 500 V +/-10%					
Motor output rating (kW/hp)	45 / 60	55 / 75	55 / 75	75 / 100	75 / 100	90 / 120
Continuous output (kVA) @400V	58.2	70.6	70.6	95.6	95.6	116
Output current (max. continuous) @ 400 V (A) *	84	102	102	138	138	168
Input current (max.) (A)	113		152		185	
Recommended mains fuse (A)	125		160		200	
Fuse order code	3NA3032		3NA3036		3NA3140	
Recommended lead cross-section (mm ²)	Input (min.)	50		70		95
	Output (min.)	50		70		95
Dimensions (mm) (w x h x d)	IP21 / NEMA 1	420 x 850 x 310				
	IP20 / NEMA 1 with integrated filter	420 x 1150 x 310				
	IP56 / NEMA 4/12	500 x 1150 x 570				
Weight (kg)	IP21 / NEMA 1	57.0		58.5		60
	IP20 / NEMA 1 with integrated filter	87		88		90
	IP56 / NEMA 4/12	80		85		90

* Output current ratings are reduced by 10% when operating on mains supply voltages over 460V.

525V - 575 V Three Phase MIDIMASTER Vector Inverters															
Order No. - IP21 / NEMA 1 (6SE32..)	13-8FG40		16-1FG40		18-0FG40		21-1FG40		21-7FG40		22-2FH40		22-7FH40		
Order No. - IP56 / NEMA 4/12 (6SE32..)	13-8FS45		16-1FS45		18-0FS45		21-1FS45		21-7FS45		22-2FS45		22-7FS45		
Inverter model	MDV220/4		MDV400/4		MDV550/4		MDV750/4		MDV1100/4		MDV1500/4		MDV1850/4		
Constant Torque (CT)	CT	VT	CT	VT	CT	VT	CT	VT	CT	VT	CT	VT	CT	VT	
Variable Torque (VT)															
Input voltage range	3 AC 525V - 575 V +/-15%														
Motor output rating (kW/hp)	22/3	4/5	4/5	55/75	55/75	75/10	75/10	11/15	11/15	15/20	15/20	185/25	185/25	22/30	
Continuous output (kVA) @ 575V	3.9	6.1	6.1	9.0	9.0	11	13.9	16.9	19.4	21.9	23.5	26.9	28.4	31.8	
Output current (max. continuous) @ 575 V (A)	3.9	6.1	6.1	9.0	9.0	11	11.0	17.0	17.0	22.0	22.0	27.0	27.0	32.0	
Input current (max.) (A)	7		10		12		18		24		29		34		
Recommended mains fuse (A)	10				16		25		32				40		
Fuse order code	3NA3803 - 6				3NA3805 - 6		3NA3810 - 6		3NA3814 - 6				3NA3820 - 6		
Recommended lead cross-section (mm ²)	Input (min.)	1.5				2.5		4		6		10			
	Output (min.)	1.5				2.5		4		6		10			
Dimensions (mm) (w x h x d)	IP21 / NEMA 1	275 x 450 x 210										275 x 550 x 210			
	IP56 / NEMA 4/12	360 x 675 x 351										360 x 775 x 422			
Weight (kg)	IP21 / NEMA 1	11.0		11.5		11.5		11.5		12.0		16.0		17.0	
	IP56 / NEMA 4/12	22.0		24.0		26.0		29.0		30.0		39.0		40.0	

525V - 575 V Three Phase MIDIMASTER Vector Inverters						
Order No. - IP21 / NEMA 1 (6SE32..)	23-2FJ40		24-1FJ40		25-2FJ40	
Order No. - IP56 / NEMA 4/12 (6SE32..)	23-2FS45		24-1FS45		25-2FS45	
Inverter model	MDV2200/4		MDV3000/4		MDV3700/4	
Constant Torque (CT)	CT	VT	CT	VT	CT	VT
Variable Torque (VT)						
Input voltage range	3 AC 525V - 575 V +/-15%					
Motor output rating (kW/hp)	22 / 30	30 / 40	30 / 40	37 / 50	37 / 50	45 / 60
Continuous output (kVA) @ 575V	33.6	40.8	44.6	51.7	54.4	61.7
Output current (max. continuous) @ 575 V (A)	32.0	41.0	41.0	52.0	52.0	62.0
Input current (max.) (A)	45		55		65	
Recommended mains fuse (A)	50		63		80	
Fuse order code	3NA3820 - 6		3NA3822 - 6		3NA3824 - 6	
Recommended lead cross-section (mm ²)	Input (min.)	10		16		25
	Output (min.)	10				16
Dimensions (mm) (w x h x d)	IP21 / NEMA 1	275 x 650 x 285				
	IP56 / NEMA 4/12	360 x 875 x 483				
Weight (kg)	IP21 / NEMA 1	27.5		28.0		28.5
	IP56 / NEMA 4/12	50.0		52.0		54.0

Input frequency:	47 Hz to 63 Hz
Mains supply impedance:	> 1% (fit input choke if < 1%)
Power factor:	≥ 0.7
Output frequency range:	0 Hz to 650 Hz
Resolution:	0.01 Hz
Overload capability:	200% for 3 s and then 150% for 60 s (related to nominal current)
Protection against:	Inverter overtemperature. Overvoltage and undervoltage
Additional protection:	Against short-circuits and earth/ground faults pull-out protection. Protection against running with no load (open-circuit)
Operating mode:	4 quadrants possible. (Re-generation back into mains not possible).
Regulation and control:	Sensorless vector; FCC (Flux Current Control); voltage/frequency curve;
Analogue input / PID input:	Unipolar: 0 ~ 10 V / 2 ~ 10 V (recommended potentiometer 4.7 kΩ) 0 ~ 20 mA / 4 ~ 20 mA Bipolar: -10 ~ 0 ~ +10V
Analogue setpoint resolution:	10-bit
Analogue output:	0 - 20 mA / 4 - 20 mA @ 0 - 500Ω; stability 5%
Setpoint stability:	Analogue < 1% Digital < 0.02%
Motor temperature monitoring:	PTC input, I ² t control
Ramp times:	0 - 650 s
Control outputs:	2 relays 230 V AC / 0.8 A (overvoltage cat.2); 30 V DC / 2 A WARNING: External inductive loads must be suppressed (see section 1.2)
Interface:	RS485
Inverter efficiency:	97%
Operating temperature:	0°C to +50°C (MMV), 0°C to +40°C (MDV)
Storage/transport temperature:	-40°C to +70°C
Ventilation:	Fan cooling (software controlled)
Humidity:	95% non-condensing
Installation height above sea level:	< 1000 m
Degree of protection:	MMV: IP20 (NEMA 1) (National Electrical Manufacturers' Association) MDV: IP21 (NEMA 1) and IP56 (NEMA 4/12)
Protective separation of circuits:	Double insulation or protective screening.
Electromagnetic compatibility (EMC):	See section 9.3

Comment:

MICROMASTER Vector and MIDIMASTER Vector are designed for use worldwide and therefore for wide line supply voltage ranges (1/3-ph. 208 - 240 V AC ±10%; 3-ph. 380 - 500 V AC ±10%; 3-ph. 525 - 575V AC ±15%)

For the voltage data, it should be noted that:

- the operating range of the drive inverter lies between the two specified voltage values - e.g. 208 - 240V,
- the ±10% does not represent an operating range but only the range which is provided to absorb brief voltage fluctuations.

Options / Accessories

Braking resistor (MMV only)
Braking Unit (MDV only)
RFI suppression filter
IP20 / NEMA 1 Accessory kit (MMV.FSA only)
Clear Text Display (OPM2)
PROFIBUS Module (CB15)
CANbus Module (CB16)
SIMOVIS software for control via PC
Output chokes and line chokes
Output filters

*Please contact your local
Siemens sales office for
further details.*

9. SUPPLEMENTARY INFORMATION

9.1 Application Example

Set-up procedure for a simple application

Motor:	230 V 1.5 kW output power
Application requirements:	Setpoint adjustable via potentiometer 0 - 50 Hz Ramp-up from 0 to 50 Hz in 15 seconds Ramp-down from 50 to 0 Hz in 20 seconds
Inverter used:	MMV150 (6SE3216-8BB40)
Settings:	P009 = 2 (all parameters can be altered) P080 - P085 = values given on motor rating plate P006 = 1 (analogue input) P002 = 15 (Ramp-up time) P003 = 20 (Ramp-down time)

This application is now to be modified as follows:

Operation of motor up to 75 Hz
(voltage/frequency curve is linear up to 50 Hz).
Motor potentiometer setpoint in addition to
analogue setpoint .
Use of analogue setpoint at maximum 10 Hz.

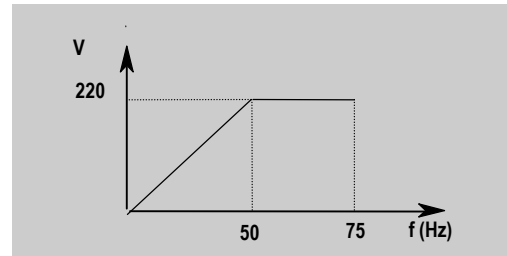

Settings:	P009 = 2 (all parameters can be altered) P013 = 75 (maximum motor frequency in Hz) P006 = 2 (setpoint via motor potentiometer or fixed setpoint) P024 = 1 (analogue setpoint is added) P022 = 10 (maximum analogue setpoint at 10 V = 10 Hz)
-----------	--

9.2 USS Status Codes

The following list gives the meaning of status codes displayed on the front panel of the inverter when the serial link is in use and parameter P001 is set to 006:

001	Message OK
002	Slave address received
100	Invalid start character
101	Time-out
102	Checksum error
103	Incorrect message length
104	Parity fail

Notes

- (1) The display flashes whenever a byte is received, thus giving a basic indication that a serial link connection is established.
- (2) If '100' flashes on the display continuously, this usually indicates a bus termination fault.

9.3 Electro-Magnetic Compatibility (EMC)

All manufacturers / assemblers of electrical apparatus which performs a complete intrinsic function which is placed on the market as a single unit intended for the end user must comply with the EMC directive EEC/89/336 after January 1996. There are three routes by which the manufacturer/assembler can demonstrate compliance:

1. *Self-Certification*

This is a manufacturer's declaration that the European standards applicable to the electrical environment for which the apparatus is intended have been met. Only standards which have been officially published in the Official Journal of the European Community can be cited in the manufacturer's declaration.

2. *Technical Construction File*

A technical construction file can be prepared for the apparatus describing its EMC characteristics. This file must be approved by a 'Competent Body' appointed by the appropriate European government organisation. This approach allows the use of standards which are still in preparation.

3. *EC Type-Examination Certificate*

This approach is only applicable to radio communication transmitting apparatus.

The MICROMASTER Vector and MIDIMASTER Vector units do not have an intrinsic function until connected with other components (e.g. a motor). Therefore, the basic units are not allowed to be CE marked for compliance with the EMC directive. However, full details are provided below of the EMC performance characteristics of the products when they are installed in accordance with the wiring recommendations in section 1.2.

Compliance Table (MMV):

Model No.	EMC Class
MMV12 - MMV300	Class 2
MMV12/2 - MMV400/2	Class 1
MMV12/2 - MM400/2 with external filter (see table) 1 phase input only	Class 2*
MMV37/3 - MMV750/3	Class 1
MMV220/3F - MMV750/3F	Class 2*
MMV37/3 - MMV750/3 with external filter (see table, class A)	Class 2*
MMV37/3 - MMV750/3 with external filter (see table, class B)	Class 3*

Compliance Table (MDV):

Model No.	EMC Class
MDV750/3 - MDV7500/3	Class 1
MDV550/2 - MDV4500/2 with class A external filter (see table)	Class 2*
MDV550/2 - MDV1850/2 with class B external filter (see table)	Class 3*
MDV550/2 - MDV4500/2	Class 1
MDV750/3 - MDV7500/3 with class A external filter (see table)	Class 2*
MDV750/3 - MDV3700/3 with class B external filter (see table)	Class 2*
MDV750/4 - MDV3700/4	Class 1

* If the installation of the inverter reduces the radio frequency field emissions (e.g. by installation in a steel enclosure), Class 3 radiated emission limits will typically be met.

Filter Part Numbers:

Inverter Model No.	Class A Filter Part No.	Class B Filter Part No.	Standard
MMV12 - MMV300	Built-in		EN 55011 / EN 55022
MMV220F - MMV750F	Built-in		EN 55011 / EN 55022
MMV12/2 - MMV25/2		6SE3290-0BA87-0FB0	EN 55011 / EN 55022
MMV37/2 - MMV75/2		6SE3290-0BA87-0FB2	EN 55011 / EN 55022
MMV110/2 - MMV150/2		6SE3290-0BB87-0FB4	EN 55011 / EN 55022
MMV220/2 - MMV300/2		6SE3290-0BC87-0FB4	EN 55011 / EN 55022
MMV37/3 - MMV150/3	6SE3290-0DA87- 0FA1	6SE3290-0DA87-0FB1	EN 55011 / EN 55022
MMV220/3 - MMV300/3	6SE3290-0DB87- 0FA3	6SE3290-0DB87-0FB3	EN 55011 / EN 55022
MMV400/3 - MMV750/3	6SE3290-0DC87- 0FA4	6SE3290-0DC87-0FB4	EN 55011 / EN 55022
MDV550/2	6SE3290-0DG87- 0FA5	6SE2100-1FC20	EN 55011 / EN 55022
MDV750/2	6SE3290-0DH87- 0FA5	6SE2100-1FC20	EN 55011 / EN 55022
MDV1100/2 - MDV1850/2	6SE3290-0DJ87- 0FA6	6SE2100-1FC21	EN 55011 / EN 55022
MDV2200/2	6SE3290-0DJ87- 0FA6		EN 55011 / EN 55022
MDV3000/2 - MDV4500/2	6SE3290-0DK87- 0FA7		EN 55011 / EN 55022
MDV 750/3 - MDV1100/3	6SE3290-0DG87- 0FA5	6SE2100-1FC20	EN 55011 / EN 55022
MDV1500/3 - MDV1850/3	6SE3290-0DH87- 0FA5	6SE2100-1FC20	EN 55011 / EN 55022
MDV2200/3 - MDV3700/3	6SE3290-0DJ87- 0FA6	6SE2100-1FC21	EN 55011 / EN 55022
MDV4500/3 - MDV7500/3	6SE3290-0DK87- 0FA7		EN 55011 / EN 55022

Note: Maximum mains supply voltage when filters are fitted is 460V.

Three classes of EMC performance are available as detailed below. Note that these levels of performance are only achieved when using the default switching frequency (or less) and a maximum motor cable length of 25 m.

Class 1: General Industrial

Compliance with the EMC Product Standard for Power Drive Systems EN 61800-3 for use in **Second Environment (Industrial) and Restricted Distribution**.

EMC Phenomenon	Standard	Level
<i>Emissions:</i>		
Radiated Emissions	EN 55011	Level A1 *
Conducted Emissions	EN 61800 - 3	*
<i>Immunity:</i>		
Electrostatic Discharge	EN 61000-4-2	8 kV air discharge
Burst Interference	EN 61000-4-4	2 kV power cables, 1 kV control
Radio Frequency Electromagnetic Field	IEC 1000-4-3	26-1000 MHz, 10 V/m

* Emission limits not applicable inside a plant where no other consumers are connected to the same electricity supply transformer.

Class 2: Filtered Industrial

This level of performance will allow the manufacturer/assembler to self-certify their apparatus for compliance with the EMC directive for the industrial environment as regards the EMC performance characteristics of the power drive system. Performance limits are as specified in the Generic Industrial Emissions and Immunity standards EN 50081-2 and EN 50082-2.

EMC Phenomenon	Standard	Level
<i>Emissions:</i>		
Radiated Emissions	EN 55011	Level A1
Conducted Emissions	EN 55011	Level A1
<i>Immunity:</i>		
Supply Voltage Distortion	IEC 1000-2-4 (1993)	
Voltage Fluctuations, Dips, Unbalance, Frequency Variations	IEC 1000-2-1	
Magnetic Fields	EN 61000-4-8	50 Hz, 30 A/m
Electrostatic Discharge	EN 61000-4-2	8 kV air discharge
Burst Interference	EN 61000-4-4	2 kV power cables, 2 kV control
Radio Frequency Electromagnetic Field, amplitude modulated	ENV 50 140	80-1000 MHz, 10 V/m, 80% AM, power and signal lines
Radio-frequency Electromagnetic Field, pulse modulated	ENV 50 204	900 MHz, 10 V/m 50% duty cycle, 200 Hz repetition rate

Class 3: Filtered - for residential, commercial and light industry

This level of performance will allow the manufacturer / assembler to self-certify compliance of their apparatus with the EMC directive for the residential, commercial and light industrial environment as regards the EMC performance characteristics of the power drive system. Performance limits are as specified in the generic emission and immunity standards EN 50081-1 and EN 50082-1.

EMC Phenomenon	Standard	Level
<i>Emissions:</i>		
Radiated Emissions	EN 55022	Level B1
Conducted Emissions	EN 55022	Level B1
<i>Immunity:</i>		
Electrostatic Discharge	EN 61000-4-2	8 kV air discharge
Burst Interference	EN 61000-4-4	1 kV power cables, 0.5 kV control

Note:

The MICROMASTER Vector and MIDIMASTER Vector units are intended **exclusively for professional applications**. Therefore, they do not fall within the scope of the harmonics emissions specification EN 61000-3-2.

9.4 Environmental Aspects

Transport and Storage

Protect the inverter against physical shocks and vibration during transport and storage. The unit must also be protected against water (rainfall) and excessive temperatures (see section 8).

The inverter packaging is re-usable. Retain the packaging or return it to the manufacturer for future use.

Dismantling and Disposal

The unit can be broken-down to it's component parts by means of easily released screw and snap connectors.

The component parts can be re-cycled, disposed of in accordance with local requirements or returned to the manufacturer.

Documentation

This handbook is printed on chlorine-free paper which has been produced from managed sustainable forests. No solvents have been used in the printing or binding process.

9.5 User's Parameter

Settings

Record your own parameter settings in the tables below (Note: ☆☆☆ = Value depends on the rating of the inverter):

Parameter	Your setting	Default
P000		-
P001		0
P002		10.0
P003		10.0
P004		0.0
P005		5.00
P006		0
P007		1
P009		0
P010		1.00
P011		0
P012		0.00
P013		50.00
P014		0.00
P015		0
P016		0
P017		1
P018		0
P019		2.00
P021		0.00
P022		50.00
P023		0
P024		0
P025		0
P026		0
P027		0.00
P028		0.00
P029		0.00
P031		5.00
P032		5.00
P033		10.0
P034		10.0
P040		0
P041		5.00
P042		10.00
P043		15.00
P044		20.00
P045		0
P046		25.0
P047		30.0
P048		35.0
P049		40.0
P050		0
P051		1
P052		2
P053		6
P054		6

Parameter	Your setting	Default
P055		6
P056		0
P057		1.0
P061		6
P062		8
P063		1.0
P064		1.0
P065		1.0
P066		0
P069		1
P070		0
P071		0
P072		250
P073		0
P074		3
P075		0
P076		0/4
P077		1
P078		100
P079		0
P080		☆☆☆
P081		50.00
P082		☆☆☆
P083		☆☆☆
P084		☆☆☆
P085		☆☆☆
P086		150
P087		0
P088		0
P089		☆☆☆
P091		0
P092		6
P093		0
P094		50.00
P095		0
P099		0
P101		0
P111		☆☆☆
P112		☆☆☆
P113		☆☆☆
P121		1
P122		1
P123		1
P124		1
P125		1
P128		120
P131		-
P132		-
P133		-
P134		-
P135		-

Parameter	Your setting	Default
P137		-
P138		-
P139		-
P140		-
P141		-
P142		-
P143		-
P186		200
P201		0
P202		1.0
P203		0.00
P204		0.0
P205		1
P206		0
P207		100
P208		0
P210		-
P211		0.0
P212		100.00
P220		0
P321		0.00
P322		50.00
P323		0
P356		6
P386		1.0
P387		1.0
P700		-
P701		-
P702		-
P720		0
P721		-
P722		0.0
P723		-
P724		0
P725		-
P726		0.0
P880		-
P910		0
P918		-
P922		-
P923		0
P927		-
P928		-
P930		-
P931		-
P944		0
P947		-
P958		-
P963		-
P967		-
P968		-
P970		-

P971		1
------	--	---

Herausgegeben vom
Bereich Automatisierungs- und Antriebstechnik (A&D)
Geschäftsgebiet Standard Drives
Postfach 3269, D-91050 Erlangen

Siemens plc
Automation & Drives
Standard Drives Division
Siemens House
Varey Road
Congleton CW12 1PH

~~Bestell-Nr. 6SE3286-4AB66~~

Änderungen vorbehalten
Specification subject to change without prior notice

G85139-H1751-U529-D1

6SE3286-4AB66

H1751-U529-D1

© Siemens plc 1999
Printed in England