

MITSUBISHI

PROGRAMMABLE CONTROLLER

MELSEC-A

User's Manual

D/A converter module type A1S62DA (Hardware)

INTRODUCTION

Thank you for choosing the Mitsubishi MELSEC-A Series of General Purpose Programmable Controllers. Please read this manual carefully so that the equipment is used to its optimum. A copy of this manual should be forwarded to the end User.



IB (NA) 66482-A (9406) ROD

1. GENERAL DESCRIPTION

1 GENERAL DESCRIPTION

This manual describes specifications, handling and wiring of an A1S62DA D/A converter module (hereinafter referred to as the A1S62DA).

1.1 Related Manual

- A1S62DA user's manual (IB-66335)
Describes details of specifications, functions and programming of an A1S62DA.

2. SPECIFICATIONS

2 SPECIFICATIONS

2.1 General Specifications

Item	Specifications					
Operating ambient temperature	0 to 55 °C (See the important notice described below)					
Storage ambient temperature	-20 to 75 °C					
Operating ambient humidity	10 to 90 %RH, non condensing					
Storage ambient humidity	10 to 90 %RH, non condensing					
Vibration resistance	Conforms to *2 JIS C 0911	Frequency	Acceleration	Amplitude	Sweep Count	
		10 to 55 Hz	—	0.075 mm (0.003 inch)		10 times *1 (1 octave/ minute)
		55 to 150 Hz	9.8 m/s ² (1 g)	—		
Shock resistance	Conforms to *2 JIS C 0912 (98 m/s ² (10 g) x 3 times in d directions)					

Item	Specifications
Noise durability	By noise simulator of 1500 Vpp noise voltage, 1 μs noise width and 25 to 60 Hz noise frequency
Dielectric withstand voltage	1500 VAC for 1 minute across AC external terminals and ground 500 VAC for 1 minute across DC external terminals and ground
Insulation resistance	500 MΩ or larger by 500 VDC insulation resistance tester across AC external terminals and ground
Grounding	Class 3 grounding; ground to the panel if proper grounding is not available
Operating ambience	Free of corrosive gases and mist. Dust should be minimal.
Cooling method	Self-cooling

REMARK

- One octave marked *1 indicates a change from the initial frequency to double or half frequency. For example, any of the changes from 10 Hz to 20 Hz, from 20 Hz to 40 Hz, from 40 Hz to 20 Hz, and 20 Hz to 10 Hz are referred to as one octave.
- *2 JIS Japanese Industrial Standard

IMPORTANT

Restriction for UL standard approved products

In order to be recognized as UL listed products, the following restrictions apply;

- Operating ambient temperature is limited from 0 to 50 °C
- A class 2 power supply recognized by the UL standard must be used

The United States	Mitsubishi Electronics America, Inc. (Industrial Automation Division) 800 Biermann Court, Mt. Prospect, IL 60056 Phone: (708)298-9223
Canada	Mitsubishi Electric Sales Canada, Inc. (Industrial Automation Division) 4299 14th Avenue, Markham, Ontario L3R 0J2 Phone: (416)475-7728
United Kingdom	Mitsubishi Electric UK Ltd. (Industrial Automation Division) Travellers Lane, Hatfield, Herts AL10 8XB Phone: (0707)276100
Germany	Mitsubishi Electric Europe GmbH, (Industrial Automation Division) Gothaer Strasse 8, Postfach 1548, D 4030 Ratingen 1 Phone: (02102)4860
Taiwan	Setuyo Enterprise Co., Ltd., (106) 11th Fl. Chung Ling Bldg. 363 Sec 2 Fu Hsing S. Rd. Taipei Taiwan R.O.C. Phone: (02)732-0161
Hongkong (& China)	Ryoden International Ltd. (Industrial & Electrical Controls Division) 10/F. Manulife Tower, 169 Electric Rd. North Point, Hong Kong Phone: 8878870
Singapore (& Malaysia)	MELCO Sales Singapore Pte. Ltd. (Industrial Division) 307 Alexandra Rd. #05-01/02, Mitsubishi Electric Bldg. Singapore 0315 Phone: 4732308
Thailand	F.A. Tech Co. Ltd. 1138/33-34 Rama 3 Rd., Yannawa, Bangkok 10120 Phone: (02)295-2861-4
Australia	Mitsubishi Electric Australia Pty. Ltd. (Industrial Controls Division) 348 Victoria Rd., Rydalmere, N.S.W. 2116 Phone: (02)684-7200
Republic of South Africa	M.S.A. Manufacturing (Pty) Ltd. (Factory Automation Division) P.O. Box 39733, Bramley, Johannesburg 2018 Phone: (011)444-8080

MITSUBISHI ELECTRIC CORPORATION

HEAD OFFICE: MITSUBISHI DENKO BLDG. MARUNOUCHI, TOKYO 100. TELEX: J24532. CABLE: MELCO.
TOKYO NAGOYA WORKS: 1-14 YADA-MURAHI 5, HIGASHI-KU, NAGOYA, JAPAN

When exported from Japan, this manual does not require application to the Ministry of International Trade and Industry for service transaction permission.

Printed in Japan

Specifications subject to change without notice

2.2 Performance Specifications

Item		Specifications							
		Voltage Output			Current Output				
Digital input	1/4000	-4000 to 4000			0 to 4000				
	1/8000	-8000 to 8000			0 to 8000				
	1/12000	-12000 to 12000			0 to 12000				
Analog output		-10 to 0 to 10 VDC (External load resistance 2 K Ω to 1 M Ω)			0 to 20 mADC (External load resistance 0 to 600 Ω)				
I/O characteristics	Resolution	1/4000	1/8000	1/12000	Analog output value *1	1/4000	1/8000	1/12000	Analog output value *2
	Digital input value	4000	8000	12000	10 V	4000	8000	12000	20 mA
		2000	4000	6000	5 V	2000	4000	6000	12 mA
		0	0	0	0 V	0	0	0	4 mA
		-2000	-4000	-6000	-5 V				
		-4000	-8000	-12000	-10 V				
Maximum resolution of analog value	1/4000	2.5 mV (10 V)			5 μ A (20 mA)				
	1/8000	1.25 mV (10 V)			2.5 μ A (20 mA)				
	1/12000	0.83 mV (10 V)			1.7 μ A (20 mA)				
Overall accuracy	$\pm 1.0\%$ (accuracy to the maximum value)								
Maximum conversion time	Maximum 25 msec/2 channels (same for 1 channel)								
Absolute maximum output	Voltage ± 12 V Current 28 mA								
Output short circuit protection	Provided								
Analog output points	2 channels/module								
Isolation method	Photocoupler insulation between output terminals and PC power No insulation between channels								
Number of I/O points	32 points								
Offset/gain adjustment	By the test terminal (without using offset/gain adjusting knobs)								
Internal current consumption (5 VDC)	0.8 A								

- *1 When the offset value is set to 0 V and the gain value is set to 10 V
*2 When the offset value is set to 4 mA and the gain value is set to 20 mA

*3 Overall accuracy

- The overall accuracy is the accuracy of the maximum value of analog output
• Overall accuracy of the voltage (current) output is the accuracy when the output voltage setting is 10 volts (20 mA)

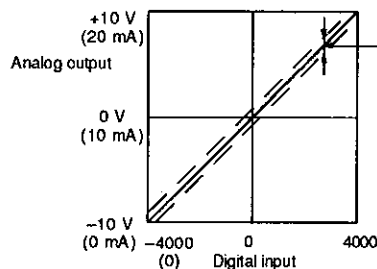

- *4 The maximum conversion speed is the time from inputting the digital value to outputting the analog value

2.3 Input/Output Conversion Characteristics

(1) Input/Output conversion characteristics

Input/Output characteristics are provided to convert a digital value specified within the CPU into an analog value and are indicated by an inclination connected between an offset value and a gain value

(2) Offset/gain values

(a) The offset and gain values are defined as follows

1) Offset value

Voltage output from the A1S62DA when the digital value specified from the PC CPU is "0"

2) Gain value

Voltage output from the A1S62DA when digital value specified from the PC CPU is "4000" (when digital value resolution setting is 1/4000)

(b) Offset/gain values set in the factory are as shown below

Item	Current Output	Voltage Output
Offset value	4mA	0 V
Gain value	20mA	10 V

(c) Offset/gain value can be changed for each channel in the test mode

2.3.1 Voltage/Current output

(1) Input/Output conversion characteristic example

(a) Voltage output

The figure on the right shows the Input/Output conversion characteristics when the offset/gain setting is provided as follows.

No	Offset Value	Gain Value
(1)	0 V	+10 V
(2)	-10 V	+10 V
(3)	+4 V	+8 V

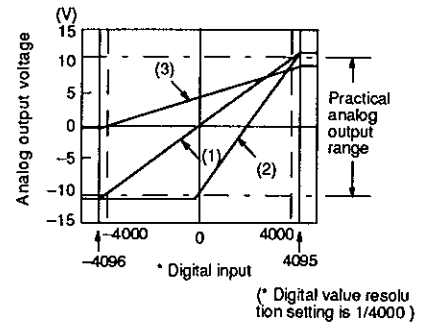

(b) Current output

The figure on the right shows the Input/Output conversion characteristics when the offset/gain setting is provided as follows

No	Offset Value	Gain Value
(1)	0 mA	20 mA
(2)	4 mA	20 mA
(3)	6 mA	16 mA

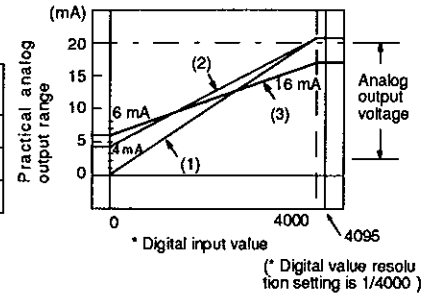

(2) Relation between the offset/gain values and the analog output

Resolution of the A1S62DA can be changed as appropriate by offset/gain setting

However, an offset/gain value less than 0 mA cannot be set. If the value is set incorrectly, an error may not occur, but an incorrect analog output may occur

Resolution and analog output are obtained as shown below

$$\text{(Resolution)} = \frac{(\text{Gain value}) - (\text{Offset value})}{(\text{Resolution of digital value})}$$

$$\text{(Analog output)} = \frac{(\text{Gain value}) - (\text{Offset value})}{(\text{Resolution of digital value})} \times (\text{Digital input}) + (\text{Offset value})$$

$$= (\text{Resolution of analog value}) \times (\text{Digital input}) + (\text{Offset value})$$



As shown in Table Performance Specifications, the maximum of the analog value resolution of the A1S62DA varies with the resolution setting

The variation of the analog output value for a change of 1 in the digital input value may not be calculated as shown above

2.4 Output Control

When the CPU is at RUN or STOP, or when an error occurs in the CPU, analog output values are controlled in accordance with the table below

Setting Combination	HOLD/CLEAR Setting	CLEAR				HOLD	
	D-A Conversion Output Enable Flag	Enable (ON)		Disable (OFF)		Enable (ON) / Disable (OFF)	
	Output Status	Enable (0)	Disable (1)	Enable (0)	Disable (1)	Enable (0)	Disable (1)
Analog output at CPU STOP	Analog value converted from digital value is output	0 V/0 mA	Offset value is output	0 V/0 mA	Analog value converted from digital value is output	0 V/0 mA	
Analog output at CPU STOP	Offset value is output	0 V/0 mA	Offset value is output	0 V/0 mA	Analog value before STOP is held	0 V/0 mA	
Analog output at CPU error occurrence	0 V/0 mA	0 V/0 mA	0 V/0 mA	0 V/0 mA	0 V/0 mA	0 V/0 mA	
Analog output at A1S62DA error occurrence	Analog value of the high or low limit is output	0 V/0 mA	Offset value is output	0 V/0 mA	Analog value of the high or low limit is output	0 V/0 mA	

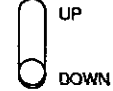
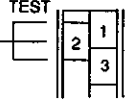
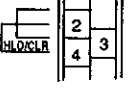
(2) Channel select switch 	Used to specify a channel for the offset/gain adjustment
(3) OFFSET/GAIN select switch 	OFFSET position: Sets the offset value GAIN position: Sets the gain value SET position: The offset/gain value is stored to the A1S62DA internal memory when the switch is moved from "OFFSET"/"GAIN" to "SET"
(4) UP/DOWN switch 	Increases or decreases the offset/gain value of the specified channel
(5) Test mode terminals 	Connected between terminals No 1 and No 3 to set the offset/gain values
(6) Output HOLD/CLEAR setting terminals 	Used to hold or clear the analog output at the time of CPU STOP Disconnected between terminal No 2 and No 4 CLEAR Connected between terminal No 2 and No 4 HOLD The analog output status of the HOLD/CLEAR setting varies with the setting of the D A conversion value output enable flag and the analog output enable/disable state

3. NOMENCLATURE

3.1 NOMENCLATURE

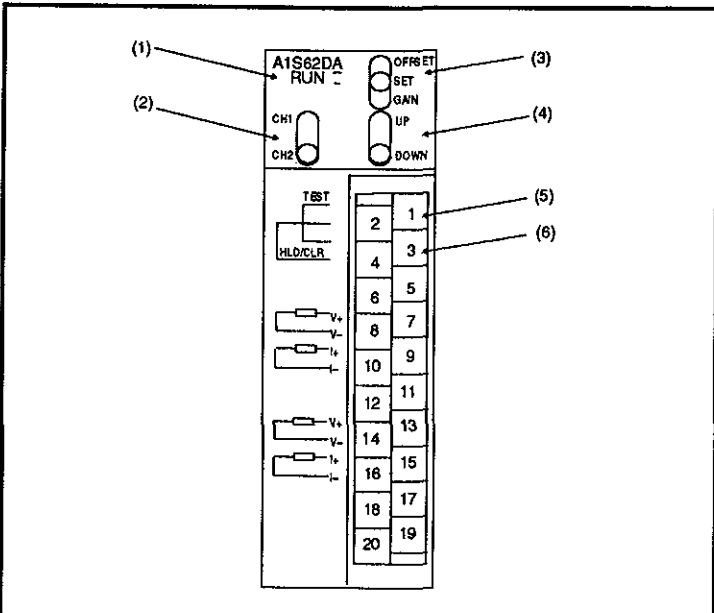

No	Description	Application
(1)	"RUN" LED 	Indicates the operating status of the A1S62DA (Normal mode) On Indicates that the A1S62DA is functional Off The 5 VDC power is not supplied or A1S62DA is faulty Flash When a digital value is written which is outside the high or low limit, this LED flashes every second (Test mode) Off OFFSET/GAIN select switch is in the "SET" position Flash: When the offset/gain select switch is set to either the OFFSET or GAIN position, this LED flashes every half (0.5) second When the offset or gain has reached the upper or lower limit this LED flashes every tenth (0.1) of a second

4. OFFSET/GAIN SETTING

4.1 OFFSET/GAIN SETTING

Factory-set Offset/Gain Values

	Voltage Output	Current Output
Gain value	10 V	20 mA
Offset value	0 V	4 mA

The offset and gain values may be changed and fine tuned in the test mode

4.1.1 Notes on Offset/Gain Setting

- (1) Do not select the test mode during execution of the D-A conversion
- (2) Offset/gain setting is allowed within the following ranges:
 - (a) Voltage -10 V to 0 V to +10 V
 - (b) Current 0mA to 20mA
- (3) The defined value is stored when the OFFSET/GAIN select switch is set to the "SET" position
- (4) Before switching from one channel to another in the test mode, the OFFSET/GAIN select switch should be in the "SET" position
- (5) The "RUN" LED light flashes quickly, at one-tenth (0.1) of a second intervals to indicate that the offset/gain specified has exceeded the allowed range

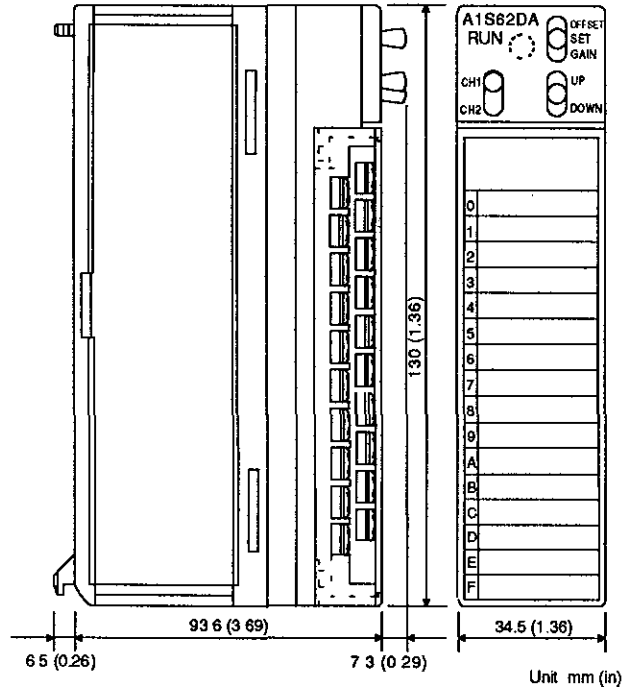
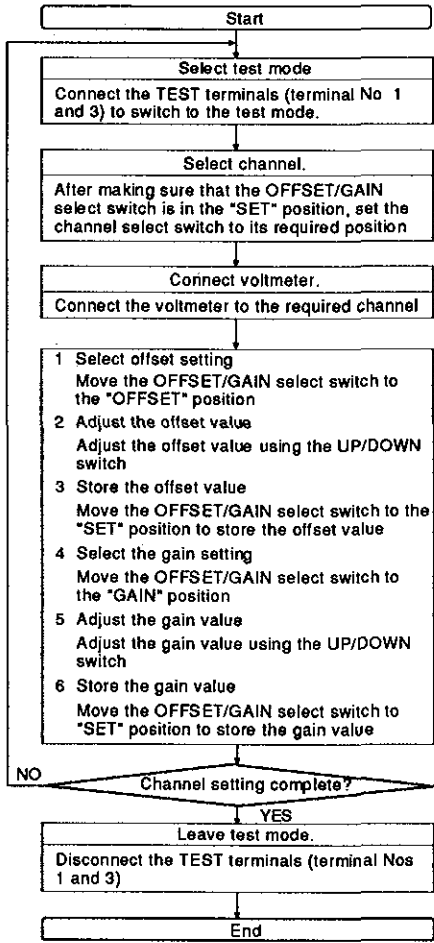

Item	Specifications
Connection terminal	20 point terminal block
Applicable wire size	0.75 to 1.5 mm ²
Applicable solderless terminal	1 25 3, 1 25-Y53A, V1 25-3, V1 25 Y53A
External dimensions mm (inch)	130 (5.12)(H) x 34.5 (1.36)(W) x 93.6 (3.69)(D)
Weight kg (lb)	0.32 Kg (0.70)

5. WIRING

5 WIRING

5.1 Wiring Instructions

- (1) Separate the main power circuit and/or high voltage wiring from the control and signal wiring
- (2) Where applicable, ground the shielding of all wires to a common ground point

5.2 Connection of A1S62DA and External Devices

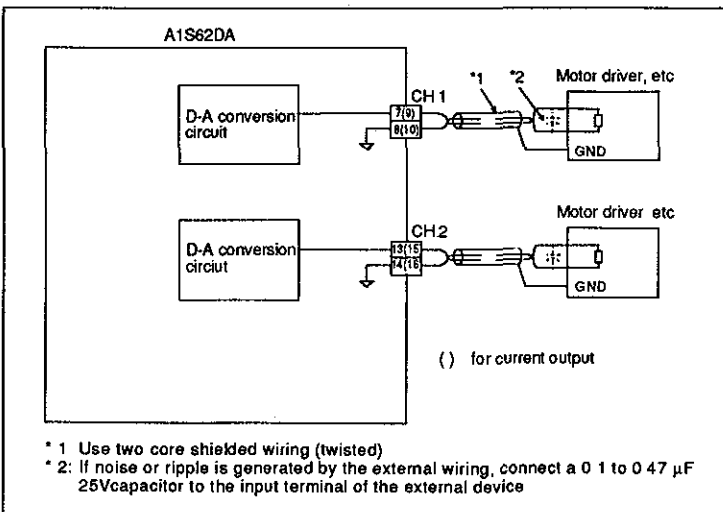

IMPORTANT

One channel cannot be used for both voltage output and current output at the same time

If both are used at the same time, the internal memory may be damaged. Therefore, make sure to disconnect any unused terminals

REVISIONS

Revision	Date	Description
A	Jun, 1994	

IMPORTANT

- (1) Design the configuration of a system to provide an external protective or safety interlocking circuit for the PCs
- (2) The components on the printed circuit boards can be damaged by static electricity, so avoid handling them directly. If it is necessary to handle them take the following precautions:
 - (a) Ground human body and work bench
 - (b) Do not touch the conductive areas of the printed circuit board and its electrical parts with non-grounded tools etc

Under no circumstances will Mitsubishi Electric be liable or responsible for any consequential damage that may arise as a result of the installation or use of this equipment

All examples and diagrams shown in this manual are intended only as an aid to understanding the text, not to guarantee operation. Mitsubishi Electric will accept no responsibility for actual use of the product based on these illustrative examples

Owing to the very great variety in possible applications of this equipment, you must satisfy yourself as to its suitability for your specific application