

cFP-CB-1 and cFP-CB-3

Compact FieldPoint Connector Blocks

These operating instructions describe how to install and use the cFP-CB-1 and cFP-CB-3 (referred to inclusively as the cFP-CB-*x*).

Features

The cFP-CB-1 and cFP-CB-3 are Compact FieldPoint connector blocks with the following features:

- cFP-CB-1 is designed for general-purpose and hazardous voltage¹ operation with all Compact FieldPoint I/O modules
- Isothermal construction of cFP-CB-3 minimizes temperature gradients for use with thermocouples
- Mount on a cFP-BP-*x* Compact FieldPoint backplane
- 36 terminals available (cFP-CB-3 has 18)
- Tie-wrap anchors for wires
- Color-coded V and C terminals for voltage supply and common connections
- -40 to 70 °C operation

¹ Hazardous voltage is voltage greater than 30 V_{rms}/42.4 V peak or 60 VDC.

FieldPoint™, National Instruments™, NI™, and ni.com™ are trademarks of National Instruments Corporation. Product and company names mentioned herein are trademarks or trade names of their respective companies. For patents covering National Instruments products, refer to the appropriate location: **Help»Patents** in your software, the `patents.txt` file on your CD, or `ni.com/patents`.

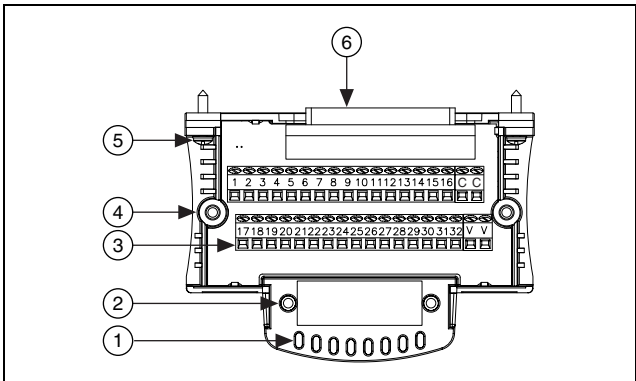

- | | |
|------------------------------------|----------------------------|
| 1 Tie-Wrap Anchors | 4 Screw Hole for Top Cover |
| 2 Screw Hole for Strain-Relief Bar | 5 Mounting Screw |
| 3 Screw Terminals | 6 37-Pin I/O Connector |

Figure 1. cFP-CB-1 Parts Locator Diagram



Note Earlier cFP-CB-1 connector blocks have a different screw-terminal numbering arrangement.

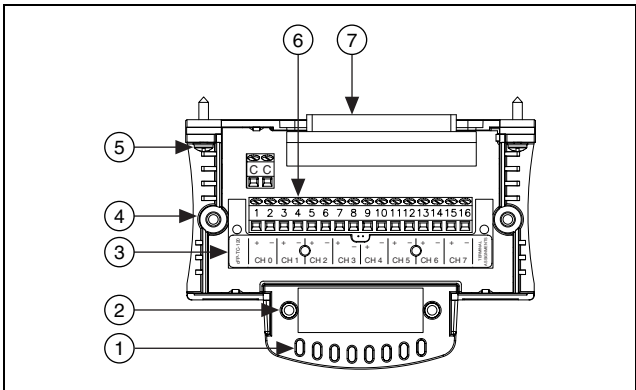

- | | |
|--|----------------------------|
| 1 Tie-Wrap Anchors | 4 Screw Hole for Top Cover |
| 2 Screw Hole for Strain-Relief Bar | 5 Mounting Screw |
| 3 Overlay Showing Channel Assignments of Screw Terminals | 6 Screw Terminals |
| | 7 37-Pin I/O Connector |

Figure 2. cFP-CB-3 Parts Locator Diagram

Wiring to the Connector Block

Refer to the I/O module operating instructions for information about wiring configurations, including detailed wiring diagrams and fuse recommendations.



Note To protect the FieldPoint system and connected devices, install appropriate external fuses on all screw terminals. Refer to the *Specifications* section for the current limits of the cFP-CB-*x* screw terminals.



Note The V terminals are internally connected to each other and the C terminals are internally connected to each other.



Caution Ensure that hazardous voltage wiring is performed only by qualified personnel adhering to local electrical standards.

1. Loosen the top cover screws and remove the cover. Refer to Figure 3.

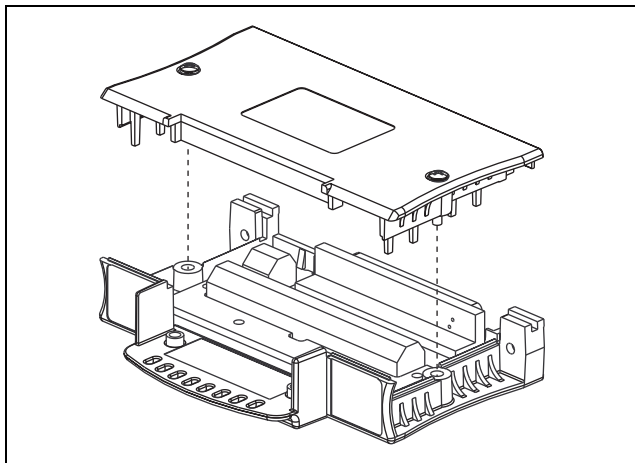

Figure 3. Removing the Top Cover from the cFP-CB-*x*

2. Verify that there are no cuts in the wire insulation that can cause a safety hazard.
3. Strip 6 mm (0.24 in.) of insulation from the ends of the wires.

4. Insert the entire stripped ends of the wires into the appropriate screw terminals. Do not allow any bare wire to show outside the screw terminals.
5. Using a 1/8 in. flathead screwdriver, tighten the screw terminals to 0.5–0.6 N · m (4.4–5.3 lb · in.) of torque.

Installing the Strain-Relief Bar

The cFP-CB-1 is shipped with two strain-relief bars, one with a foam cushion for wires and one with grooves for jacketed cables. The cFP-CB-3 has one foam-cushion strain relief bar. The tie-wrap anchors on the connector block provide additional strain relief. Figure 4 shows the two strain-relief bars.

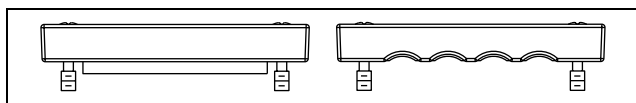

Figure 4. cFP-CB-x Strain-Relief Bars

Choose the strain-relief bar that suits your application and complete the following steps:

1. Using a number 2 Phillips screwdriver, install the strain-relief bar on the connector block as shown in Figure 5.

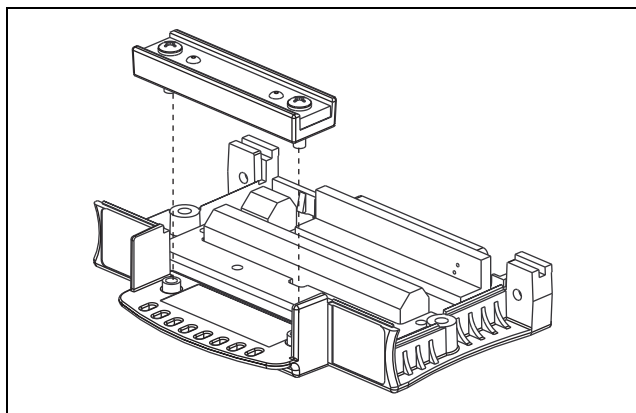

Figure 5. Installing the Strain-Relief Bar

2. Tighten the strain-relief screws. If you are using the cushioned strain-relief bar, make sure all the wires are secure against the cushion and not touching metal parts of the connector block.
3. Reinstall the top cover and tighten the top cover screws.
4. Install tie wraps as shown in Figure 6.

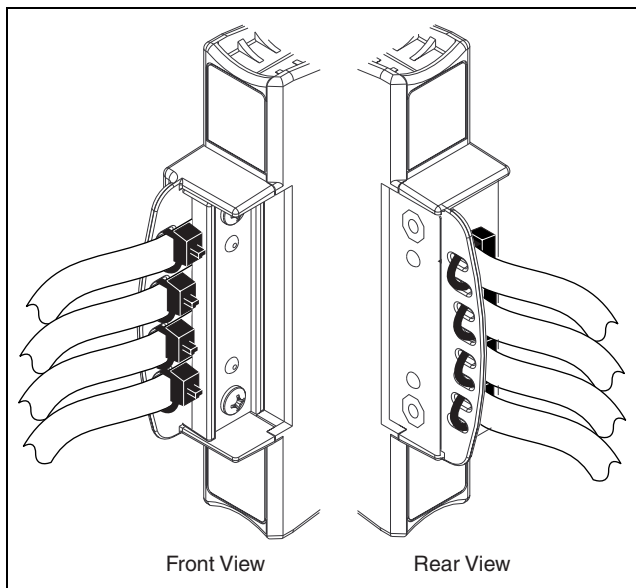

Figure 6. Tie Wraps

Installing the cFP-CB-x

To install the cFP-CB-x, refer to Figure 7 and complete the following steps:

1. Align the captive screws on the cFP-CB-x with the holes on the backplane. The shape of the I/O connector on the cFP-CB-x prevents backward insertion.
2. Press firmly to seat the cFP-CB-x on the backplane.
3. Using a number 2 Phillips screwdriver with a shank of at least 64 mm (2.5 in.) length, tighten the captive screws to 1.1 N · m (10 lb · in.) of torque. The nylon coating on the screws prevents them from loosening.

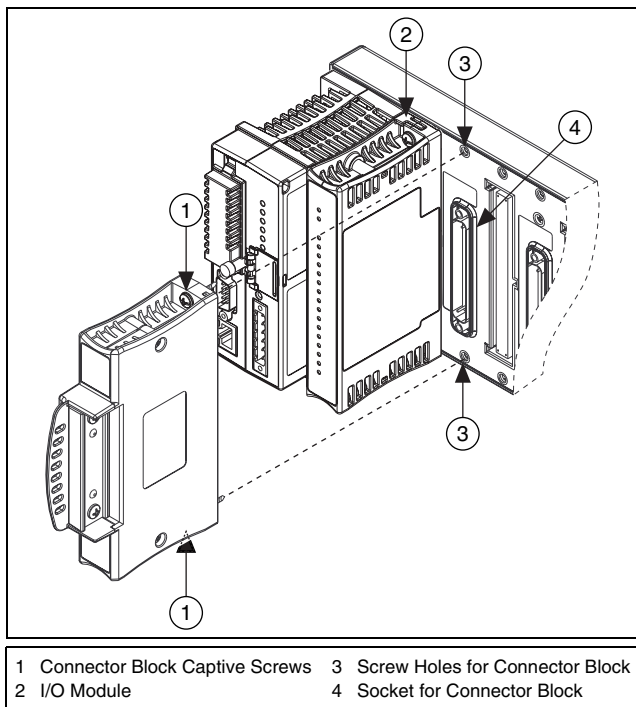

Figure 7. Installing the cFP-CB-x

Thermocouple Wiring

Compact FieldPoint thermocouple input modules can measure the temperature of the terminals on the cFP-CB-1 or cFP-CB-3 connector block. The modules use this measurement, called the *cold junction temperature*, to compensate for the thermoelectric voltages generated at these junctions. For the most accurate cold-junction compensation, use the cFP-CB-3 for connecting thermocouple signals.

Heat dissipated by adjacent modules (or other nearby heat sources) can cause errors in thermocouple measurements by heating the terminals to a different temperature than the sensor used to measure the cold junction. The thermal gradient generated across the terminals can cause the terminals of different channels to differ in temperatures. The resulting measurement creates errors in

absolute and relative accuracy between channels. The actual thermal gradient depends on the connector block you use and the details of your installation. The following section provides guidelines for minimizing thermal gradients.

Minimizing Thermal Gradients

To minimize the thermal gradient across the terminals, use the cFP-CB-3 for connecting thermocouple signals. The cFP-CB-3 is designed with *isothermal* construction to keep the terminals at the same temperature. In addition to using the cFP-CB-3, you can minimize thermal gradients by following these guidelines:

- Do not place power supplies or other heat sources directly above or below the Compact FieldPoint system.
- Do not install high-power modules, such as the cFP-DO-4xx and cFP-RLY-4xx, adjacent to the cFP-CB-3.
- Use small-gauge thermocouple wire to transfer less heat.
- Run thermocouple wires together near the connector block to keep them at the same temperature.
- Avoid running thermocouple wires near hot or cold objects.
- Use the foam cushion strain relief to restrict air flow.

Isolation and Safety Guidelines



Caution Read the following information before attempting to connect the cFP-CB-*x* to any circuits that may contain hazardous voltages.

This section describes the isolation of the cFP-CB-*x* and its compliance with international safety standards. The field wiring connections are isolated from the backplane and the inter-module communication bus. The isolation is provided by the module, which has optical and galvanic isolation barriers designed and tested to protect against transient fault voltages of up to 2,300 V_{rms}. The cFP-CB-*x* provides *double insulation* (compliant with IEC 61010-1) for working voltages of 250 V_{rms}¹. Safety standards (such as those published by UL and IEC) require the use of double insulation between hazardous voltages and any human-accessible parts or circuits.

¹ *Working voltage* is defined as the signal voltage plus the common-mode voltage. *Common-mode voltage* is the voltage of the module with respect to ground.

Never try to use any isolation product between human-accessible parts (such as DIN rails or monitoring stations) and circuits that can be at hazardous potentials under normal conditions, unless the product is specifically designed for such an application as is the cFP-CB-*x*.

Even though the cFP-CB-*x* is designed to handle applications with hazardous potentials, follow these guidelines to ensure a safe total system:

- The cFP-CB-*x* has a safety isolation barrier between the I/O channels and the inter-module communication bus. There is no isolation between channels unless otherwise noted. If any of the channels on a module are wired at a hazardous potential, make sure that all other devices or circuits connected to that module are properly insulated from human contact.
- Do *not* share the external supply voltages (the V and C terminals) with other devices (including other FieldPoint devices), unless those devices are isolated from human contact.
- You *must* connect the protective earth (PE) ground terminal on the cFP-BP-*x* backplane to the system safety ground. The backplane PE ground terminal has the following symbol stamped beside it: . Connect the backplane PE ground terminal to the system safety ground using 14 AWG (1.6 mm) wire with a ring lug. Use the 5/16 in. panhead screw shipped with the backplane to secure the ring lug to the backplane PE ground terminal.
- As with any hazardous voltage wiring, make sure that all wiring and connections meet applicable electrical codes and commonsense practices. Mount the backplane in an area, position, or cabinet that prevents accidental or unauthorized access to wiring that carries hazardous voltages.
- The isolation of the cFP-CB-*x* is certified as double-insulated for working voltages of 250 V_{rms}. Do *not* use the cFP-CB-*x* as the only isolating barrier between human contact and working voltages of more than 250 V_{rms}.
- Operate the cFP-CB-*x* only at or below Pollution Degree 2. Pollution Degree 2 means that only nonconductive pollution occurs in most cases. Occasionally, however, a temporary conductivity caused by condensation must be expected.

- Do *not* operate FieldPoint products in an explosive atmosphere or where there may be flammable gases or fumes. If you need to operate FieldPoint products in such an environment, the FieldPoint products *must* be in a suitably rated enclosure.
- Operate the cFP-CB-*x* at or below Installation Category II. Installation Category II is for measurements performed on circuits directly connected to the electrical distribution system. This category refers to local-level distribution, such as that provided by a standard wall outlet.

Specifications

The following specifications are typical for the range -40 to 70 °C, unless otherwise noted.

Installation

Terminal wiring	16–26 AWG copper conductor wire with 6 mm (0.24 in.) of insulation stripped from the end ¹
Maximum cable diameter	8 mm (5/16 in.) with cable-grooved strain relief
Torque for screw terminals	0.5–0.6 N · m (4.4–5.3 lb · in.)
Maximum current for screw terminals ²	
V and C terminals.....	4 A
All other terminals.....	2 A

Accuracy

Cold-junction accuracy 0.15 °C typ, 0.3 °C max

There is typically an additional 0.2 °C difference between the temperature of the cold-junction sensor and that of the actual terminals.

¹ Use only copper conductor wire unless you are working with a sensing device, such as a thermocouple, that requires a different type of wire.

² Use fast-acting fuses to limit the current through screw terminals. Some I/O module terminals require a lower maximum current value. Refer to the I/O module operating instructions for more information.

Physical

Weight

cFP-CB-1.....	201 g (7.1 oz)
cFP-CB-3.....	201 g (7.1 oz)

Isolation Voltage

Isolation voltage rating	250 V _{rms} , Installation Category II
Transient overvoltage.....	2,300 V _{rms}
Channel-to-channel isolation	Refer to I/O module operating instructions



Caution Improper wiring may defeat isolation barrier.

Environmental

Compact FieldPoint connector blocks are intended for indoor use only. For outdoor use, the Compact FieldPoint system *must* be mounted inside a sealed enclosure.

Operating temperature	-40 to 70 °C
Storage temperature	-55 to 85 °C
Humidity	10 to 90% RH, noncondensing
Maximum altitude.....	2,000 m; at higher altitudes, the isolation voltage ratings must be lowered
Pollution Degree	2

Shock and Vibration

Operating vibration, random (IEC 60068-2-64).....	10–500 Hz, 5 g _{rms}
Operating vibration, sinusoidal (IEC 60068-2-6).....	10–500 Hz, 5 g
Operating shock (IEC 60068-2-27).....	50 g, 3 ms half sine, 18 shocks at 6 orientations; 30 g, 11 ms half sine, 18 shocks at 6 orientations

Safety

This product is designed to meet the requirements of the following standards of safety for electrical equipment for measurement, control, and laboratory use:

- IEC 61010-1, EN 61010-1
- UL 3121-1, UL 61010C-1
- CAN/CSA C22.2 No. 1010.1

For UL, hazardous location, and other safety certifications, refer to the product label or to ni.com.

Electromagnetic Compatibility

CE, C-Tick, and FCC Part 15 (Class A) Compliant

Emissions.....	EN 55011 Class A at 10 m FCC Part 15A above 1 GHz
Immunity.....	EN 61326:1997 + A2:2001, Table 1



Note For EMC compliance, operate this device with shielded cabling.

CE Compliance

This product meets the essential requirements of applicable European Directives, as amended for CE Marking, as follows:

Low-Voltage Directive (safety).....	73/23/EEC
Electromagnetic Compatibility Directive (EMC)	89/336/EEC



Note Refer to the Declaration of Conformity (DoC) for this product for any additional regulatory compliance information. To obtain the DoC for this product, click **Declarations of Conformity Information** at ni.com/hardref.nsf/.

Where to Go for Support

For more information about setting up the Compact FieldPoint system, refer to these National Instruments documents:

- Compact FieldPoint controller user manual
- Compact FieldPoint I/O module operating instructions

Go to ni.com/support for the most current manuals, examples, and troubleshooting information.

For telephone support in the United States, create your service request at ni.com/ask and follow the calling instructions or dial 512 795 8248. For telephone support outside the United States, contact your local branch office:

Australia 1800 300 800, Austria 43 0 662 45 79 90 0,
Belgium 32 0 2 757 00 20, Brazil 55 11 3262 3599,
Canada (Calgary) 403 274 9391,
Canada (Montreal) 514 288 5722,
Canada (Ottawa) 613 233 5949, Canada (Québec) 514 694 8521,
Canada (Toronto) 905 785 0085,
Canada (Vancouver) 514 685 7530, China 86 21 6555 7838,
Czech Republic 420 2 2423 5774, Denmark 45 45 76 26 00,
Finland 385 0 9 725 725 11, France 33 0 1 48 14 24 24,
Germany 49 0 89 741 31 30, Greece 30 2 10 42 96 427,
India 91 80 51190000, Israel 972 0 3 6393737,
Italy 39 02 413091, Japan 81 3 5472 2970,
Korea 82 02 3451 3400, Malaysia 603 9131 0918,
Mexico 001 800 010 0793, Netherlands 31 0 348 433 466,
New Zealand 1800 300 800, Norway 47 0 66 90 76 60,
Poland 48 0 22 3390 150, Portugal 351 210 311 210,
Russia 7 095 238 7139, Singapore 65 6226 5886,
Slovenia 386 3 425 4200, South Africa 27 0 11 805 8197,
Spain 34 91 640 0085, Sweden 46 0 8 587 895 00,
Switzerland 41 56 200 51 51, Taiwan 886 2 2528 7227,
Thailand 662 992 7519, United Kingdom 44 0 1635 523545



323322B-01

Apr03