

# Mac E Series

Human Machine Interface

Installation Manual

# E1071



## Installation manual for the E1000 series operator terminals

# Foreword

The E1000 operator terminal is developed to satisfy the demands of human-machine communication. Built-in functions such as displaying and controlling text, dynamic indication, time channels, alarm and recipe handling are included.

The operator terminal work, for the most part, in an object-oriented way, making it easy to understand and use. The configuration operation of the terminal is made in a personal computer, using the configuration tool E-Designer. The project is then transferred and stored in the operator terminal.

The operator terminal can be connected to many types of automation equipment, such as PLCs, servos or drives. In this manual the expression "the controller" is used as a general term for the connected equipment.

This manual explains how to install the operator terminal. Please refer to the reference manual for further information.

© Mitsubishi Electric AB, MA00777, 2005-01

The information in this document is subject to change without notice and is provided as available at the time of printing. The manufacturer reserves the right to change any information without updating this publication. The manufacturer assumes no responsibility for any errors that may appear in this document. Read the entire installation manual prior to installing and using this equipment. Only qualified personnel may install, operate or repair this equipment. The manufacturer is not responsible for modified, altered or renovated equipment. Because the equipment has a wide range of applications, users must acquire the appropriate knowledge to use the equipment properly in their specific applications. Persons responsible for the application and the equipment must themselves ensure that each application is in compliance with all relevant requirements, standards and legislation in respect to configuration and safety. Only parts and accessories manufactured according to specifications set by The manufacturer may be used. THE MANUFACTURER SHALL NOT BE LIABLE TO ANYONE FOR ANY DIRECT, INDIRECT, SPECIAL, INCIDENTAL OR CONSEQUENTIAL DAMAGES RESULTING FROM THE INSTALLATION, USE OR REPAIR OF THIS EQUIPMENT, WHETHER ARISING IN TORT, CONTRACT, OR OTHERWISE. BUYER'S SOLE REMEDY SHALL BE THE REPAIR, REPLACEMENT, OR REFUND OF PURCHASE PRICE, AND THE CHOICE OF THE APPLICABLE REMEDY SHALL BE AT THE SOLE DISCRETION OF THE MANUFACTURER.



# Table of Contents

<b>1 Safety Precautions</b> .....	<b>1-1</b>
1.1 UL Installation.....	1-1
1.2 General .....	1-1
1.3 During Use .....	1-1
1.4 Service and Maintenance.....	1-2
1.5 Dismantling and Scrapping.....	1-2
<b>2 Installation</b> .....	<b>2-1</b>
2.1 Space Requirements .....	2-1
2.2 Installation Process.....	2-1
2.2.1 Mode Switches .....	2-3
2.2.2 Connections to the Controller .....	2-3
2.2.3 Other Connections and Peripherals .....	2-3
<b>3 Technical Data</b> .....	<b>3-1</b>
<b>4 Chemical Resistance</b> .....	<b>4-1</b>
4.1 Metal Casing.....	4-1
4.2 Keyboard and Display .....	4-1
4.2.1 Autotex F250.....	4-1
4.2.2 Touch Screen Surface .....	4-2
<b>5 Operator Terminal Drawings</b> .....	<b>5-1</b>
5.1 Communication Ports.....	5-1
5.2 E1071 Outline.....	5-2



# 1 Safety Precautions

Both the installer and the owner and/or operator of the operator terminal must read and understand this installation manual.

## 1.1 UL Installation

Power, input and output (I/O) wiring must be in accordance with Class 1, Division 2 wiring methods (Article 501-4 (b) of the National Electric Code, NFPA 70) and in accordance with the authority having jurisdiction.

## 1.2 General

- Only qualified personnel may install or operate the operator terminal.
- The operator terminal must be installed according to the installation instructions.
- The operator terminal is designed for stationary installation on a plane surface, where the following conditions are fulfilled:
  - no high explosive risks
  - no strong magnetic fields
  - no direct sunlight
  - no large, sudden temperature changes
- Never allow fluids, metal filings or wiring debris to enter any openings in the operator terminal. This may cause fire or electrical shock.
- The operator terminal fulfills the requirements of article 4 of EMC directive 89/336/EEC.
- Storing the operator terminal where the temperature is lower/higher than recommended in this manual can cause the LCD display liquid to congeal/become isotopic.
- The LCD display liquid contains a powerful irritant. In case of skin contact, wash immediately with plenty of water. In case of eye contact, hold the eye open, flush with plenty of water and get medical attention.
- The supplier is not responsible for modified, altered or reconstructed equipment.
- Use only parts and accessories manufactured according to specifications of the supplier.
- Peripheral equipment must be appropriate for the application and location.
- The figures in this manual serves an illustrative purpose. Because of the many variables associated with any particular installation, the supplier cannot assume responsibility for actual use based on the figures.
- The supplier neither guarantees that the operator terminal is suitable for your particular application, nor assumes responsibility for your product design, installation or operation.

## 1.3 During Use

- Keep the operator terminal clean.
- Emergency stop and other safety functions may not be controlled from the operator terminal.
- Do not use too much force or sharp objects when touching the keys, display etc.

## **1.4 Service and Maintenance**

- Only qualified personnel should carry out repairs.
- The agreed warranty applies.
- Before carrying out any cleaning or maintenance operations, disconnect the equipment from the electrical supply.
- Clean the display and surrounding front cover with a soft cloth and mild detergent.
- Replacing the battery incorrectly may result in explosion. Only use batteries recommended by the supplier.

## **1.5 Dismantling and Scrapping**

- The operator terminal or parts thereof shall be recycled according to local regulations.
- The following components contain substances that might be hazardous to health and the environment: lithium battery, electrolytic capacitor and display.



## 2 Installation

### 2.1 Space Requirements

- Installation plate thickness: 1.5 - 9.0 mm (0.06 - 0.35 inch)
- Space requirements when installing the operator terminal:

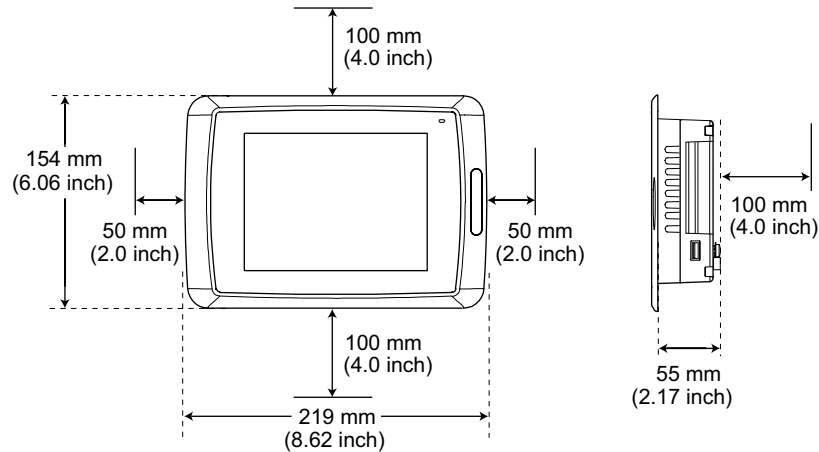

#### Caution

The openings on the enclosure are for air convection. Do not cover these openings.

### 2.2 Installation Process

1. Unpack and check the delivery. If damage is found, notify the supplier.

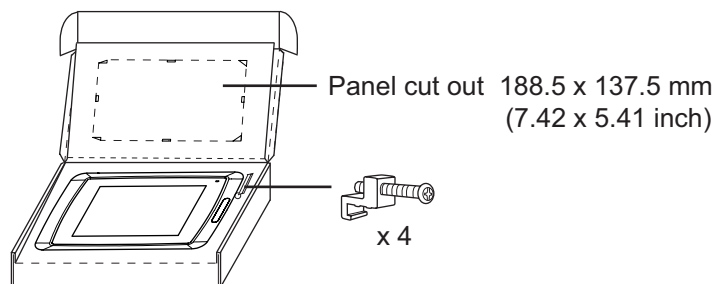

#### Note:

Place the operator terminal on a stable surface during installation. Dropping it or letting it fall may cause damage.

2. Place the panel cut out where the operator terminal is to be situated, draw along the outer sides of the holes and cut according to the markings.

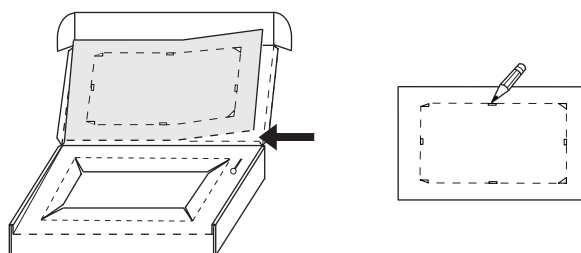

- Secure the operator terminal in position, using all the fastening holes and the provided brackets and screws:

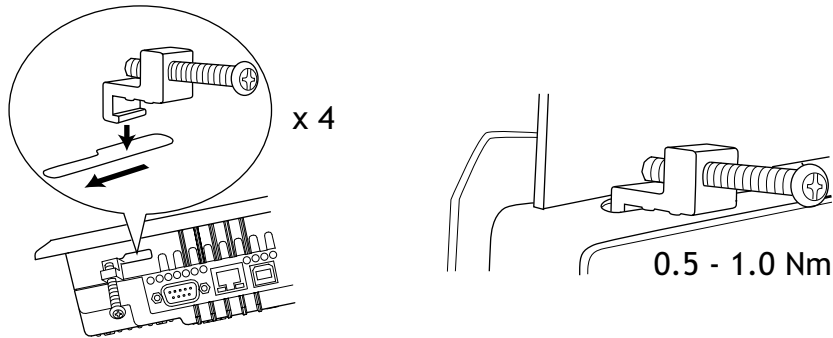

- Connect the cables in the specified order.

- Caution**

Ensure that the operator terminal and the controller system have the same electrical grounding (reference voltage level), otherwise errors in communication may occur.
- Use an M5 screw and a grounding conductor (as short as possible) with a cross-section of minimum  $2.5 \text{ mm}^2$ .
- Caution**

  - Use only shielded communication cables.
  - Separate high voltage cables from signal and supply cables.
- Caution**

  - The operator terminal must be brought to ambient temperature before it is started up. If condensation forms, ensure that the operator terminal is dry before connecting it to the power outlet.
  - Ensure that the voltage and polarity of the power source is correct.

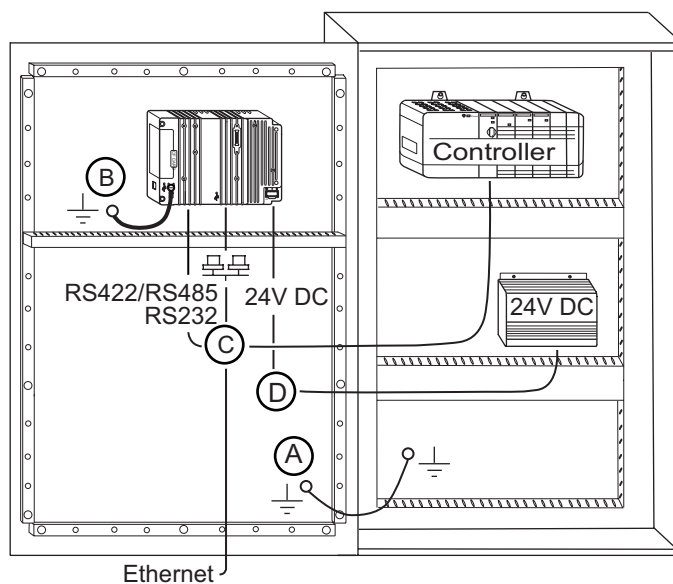

- Carefully remove the laminated film over the operator terminal display, to avoid static electricity that could damage the terminal.

## 2.2.1 Mode Switches

All mode switches must be in OFF position during operator terminal use.

The mode switches should not be touched unless by qualified personell.

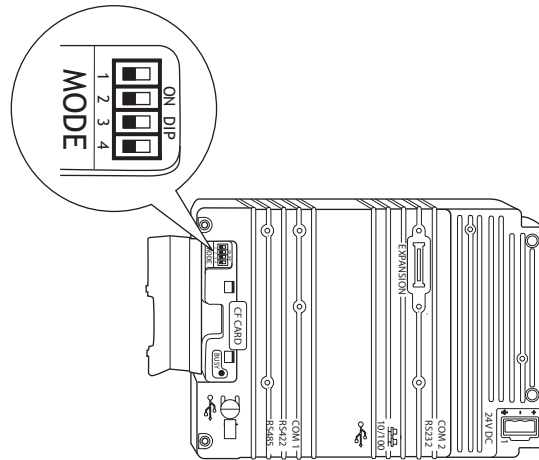

## 2.2.2 Connections to the Controller

For information about the cables to be used when connecting the operator terminal to the controller, please refer to the help file for the driver in question.

## 2.2.3 Other Connections and Peripherals

Cables, peripheral equipment and accessories must be suitable for the application and its environment. For further details or recommendations, please refer to the supplier.



### Caution

When using a compact flash card, do not remove the card when the busy indicator is illuminated.



### 3 Technical Data

Parameter	E1071
Front panel, W x H x D	219 x 154 x 6 mm
Mounting depth	55 mm (155 mm including clearance)
Front panel seal	IP 66
Rear panel seal	IP 20
Keyboard material/ Front panel	Touch screen: Polyester on glass *, 1 million finger touch operations. Overlay: Autotex F250 *.
Reverse side material	Powder-coated aluminum
Weight	1.1 kg
Serial port RS422/ RS485	25-pin D-sub contact, chassis-mounted female with standard locking screws 4-40 UNC.
Serial port RS232C	9-pin D-sub contact, male with standard locking screws 4-40 UNC.
Ethernet	Shielded RJ 45
USB	Host type A, power consumption max. 500mA Device type B
CF-slot	Compact flash, type I and II
Flash memory for application	4 MB
Real time clock	±20 PPM + error because of ambient temperature and supply voltage. Total max error: 1 min/month at 25 °C Minimum life of the real time clock battery: 3 years Temperature coefficient: 0.004 ppm/°C <sup>2</sup>
Power consumption at rated voltage	Normal: 0.4 A Maximum: 0.9 A
Display	TFT-LCD. 640 x 480 pixels, 64K color. CCFL backlight lifetime at the ambient temperature of +25 °C: 50,000 h.
Active area of display, W x H	131.5 x 98.6 mm
Fuse	Internal DC fuse, 3.15 AT, 5 x 20 mm
Power supply	+24V DC (20 - 30V DC). 3-pin jack connection block. CE: The power supply must conform with the requirements for SELV or PELV according to IEC 950 or IEC 742. UL: The power supply must conform with the requirements for class II power supplies.
Ambient temperature	Vertical installation: 0 ° to +50 °C Horizontal installation: 0 ° to +40 °C
Storage temperature	-20 ° to +70 °C
Relative humidity	5 - 85 % non-condensed
EMC tests on the operator terminal	The operator terminal conforms with the essential protection requirements in article 4 of the directive 89/336/EEC. Noise tested according to EN6100-6-4 emission and EN61000-6-2 immunity.
UL, cUL approvals	<i>Certification in progress</i>

\* See section *Chemical Resistance for keyboard and display*



## 4 Chemical Resistance

### 4.1 Metal Casing

The frame and casing material is powder-coated aluminum. This powder paint withstands exposure of up to 24 hours duration to the following chemicals without visible change:

Ammonia 25%	Isopropyl alcohol	Nitric acid 3%
De-ionized water	Tap water	Chlorhydric acid 10%
Butanol	Cooling liquid 50%	Washer fluid 33%
Citric acid 10%	Ligroin	Sulphuric acid 20%
Diesel	Cooking oil	Turpentine
Ethanol 99.5% denaturated	Lactic acid 10%	Urea saturated
FAM-Normal petrol	Sodium di-chromate saturated	Hydroperoxide 3%
Alcohol 95%	Caustic soda 5%	Acetic acid 10%
Phosphoric acid 43%	Sodium hypochlorite solution	Alu-cleaner
Glycol	Sodium carbonate 10%	-
Industrial petrol	Sodium chloride 20%	-

### 4.2 Keyboard and Display

#### 4.2.1 Autotex F250

Autotex F250 covers the overlay surrounding the touch screen.

##### Solvent Resistance

Autotex F250 withstands exposure of more than 24 hours duration under DIN 42 115 Part 2 to the following chemicals without visible change:

Potassium ferrocyanide/ ferricyanide	Sodium hypchlorite <20% (bleach)	1.1.1. Trichloroethane (Genklene)
Cyclohexanol	Acetaldehyde	Ethylacetate
Diacetone alcohol	Aliphatic hydrocarbons	Diethyl ether
Glycol	Toluene	N-Butyl acetate
Isopropanol	Xylene	Amylacetate
Glycerine	White spirit	Butyccellosolve
Methanol	Formic acid <50%	Ether
Triacetin	Acetic acid <50%	MIBK
Dowanol DRM/PM	Phosphoric acid <30%	Cutting oil
Acetone	Hydrochloric acid <36%	Potassium carbonate
Metyl ethyl ketone	Nitric acid <10%	Washing powders
Dioxan	Trichloroacetic acid <50%	Fabric conditioner
Cyclohexanone	Sulphuric acid <10%	Ferric chloride
Ethanol	Formaldehyde 37% - 42%	Ferrous chlorid
Isophorone	Potassium hydroxide <30%	Dibutyl Phthalate

Ammonia <40%	Linseed oil	Dioctyl Phthalate
Caustic soda <40%	Paraffin oil	Sodium carbonate
Hydrogen peroxide <25%	Blown castor oil	Petrol
Alkalicarbonate	Silicone oil	Teepol
Bichromate	Turpentine substitute	Water
Diesel oil	Univeral brake fluid	Sea water
Acetonitrile	Decon	-
Sodium bisulphate	Aviation fuel	-

Autotex withstands DIN 42 115 Part 2 exposure of up to 1 hour duration to glacial acetic acid without visible change.

Autotex is not resistant to high pressure steam at over 100 °C or the following chemicals:

Concentrated mineral acids	Benzyl alcohol
Concentrated caustic solution	Mehylene chloride

Autotex withstands 24 hours exposure to the following reagents at 50 °C without visible staining:

Top Job	Grape Juice	Ariel	Ajax
Jet Dry	Milk	Persil	Vim
Gumption	Coffee	Wisk	Domestos
Fantastic	-	Lenor	Vortex
Formula 409	-	Downey	Windex

Very slight discoloration was noted under critical viewing conditions with the following materials:

Tomato juice	Tomato ketchup	Lemon juice	Mustard
--------------	----------------	-------------	---------

### Outdoor Use

In common with all polyester based films Autotex F250 is not suitable for use in conditoinis of long term exposure to direct sunlight.

## 4.2.2 Touch Screen Surface

The touch screen surface on the operator terminal withstands exposure to the following solvents without visible change:

Solvents	Time
Acetone	10 minutes
Isopropanol	10 minutes
Toulene	5 hours

### Protection Film

It is recommended to use the Autoflex EB touch display protection film, supplied by Beijer Electronics AB.



# 5 Operator Terminal Drawings

## 5.1 Communication Ports

### RS-232

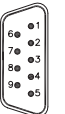

Pin no	Signal	Signal Name	Signal direction
1	DCD	Data Carrier Detect	Input
2	RD	Receive Data	Input
3	TD	Transmit Data	Output
4	DTR	Data Terminal Ready	Output
5	SG	Signal Ground	-
6	DSR	Data Set Ready	Input
7	RTS	Request To Send	Output
8	CTS	Clear To Send	Input
9	RI	Ring Indicator	Input

D-sub  
9-pin Male

### RS-422/485

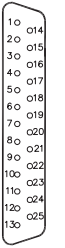

Pin no	RS-422		RS-485	
	Signal	Signal direction	Signal	Signal direction
2	TxD+	Output	Tx/Rx+	In/Output
15	TxD-	Output	Tx/Rx-	In/Output
3	RxD+	Input		
16	RxD-	Input		
4	RTS+	Output		
17	RTS-	Output		
5	CTS+	Input		
18	CTS-	Input		
20	1)			
21	1)			
6	Do not use		2) Bus termination	4) Connect to pin no.19 for bus-termination.
19	Do not use		3) Bus termination	See above
7,8	0V		0V	
14	+5V <100mA	Output	+5V <100mA	Output

D-sub  
25-pin Female

- 1) Pin no 20 connected to pin no 21 internal in the terminal
- 2) Directly connected internally to pin no. 2 (Tx/Rx+).
- 3) Connected to pin no. 15 (Tx/Rx-) internally via a 120ohm 1/4W resistor.
- 4) NOTE! Only the first and the last unit on the bus should be terminated.

### USB

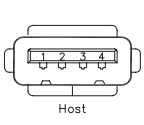

Pin no	Signal	Signal direction
1	VBUS	-
2	D-	In/Output
3	D+	In/Output
4	GND	-

Host Device

Frame connected to chassis.

### Ethernet

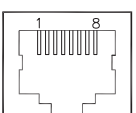

Pin no	Signal	Signal direction
1	Tx+	Output
2	Tx-	Output
3	Rx+	Input
6	Rx-	Input
4,5,7,8	GND	

Drawing No. 5005S, Date 2004-10-27

## 5.2 E1071 Outline

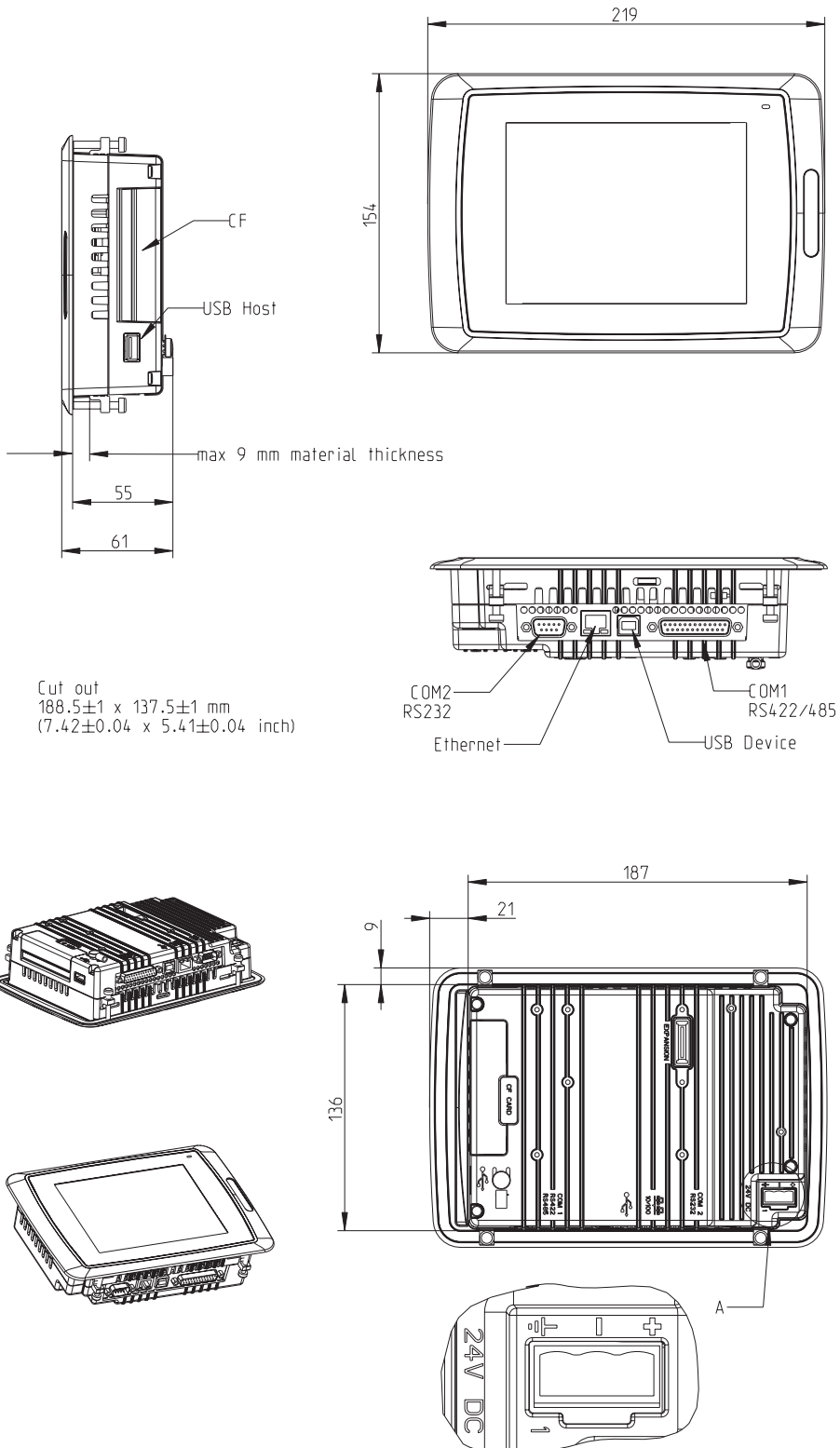

Drawing No. 5055S, Date 2004-10-26

Denna handling är vår egendom och får ej utan vårt skriftliga medgivande ändras, kopieras, användas för tillverkning eller delges annan person eller firma.

This document is our property and shall not without our permission in writing be altered, copied, used for manufacturing or communicated to any other person or company.

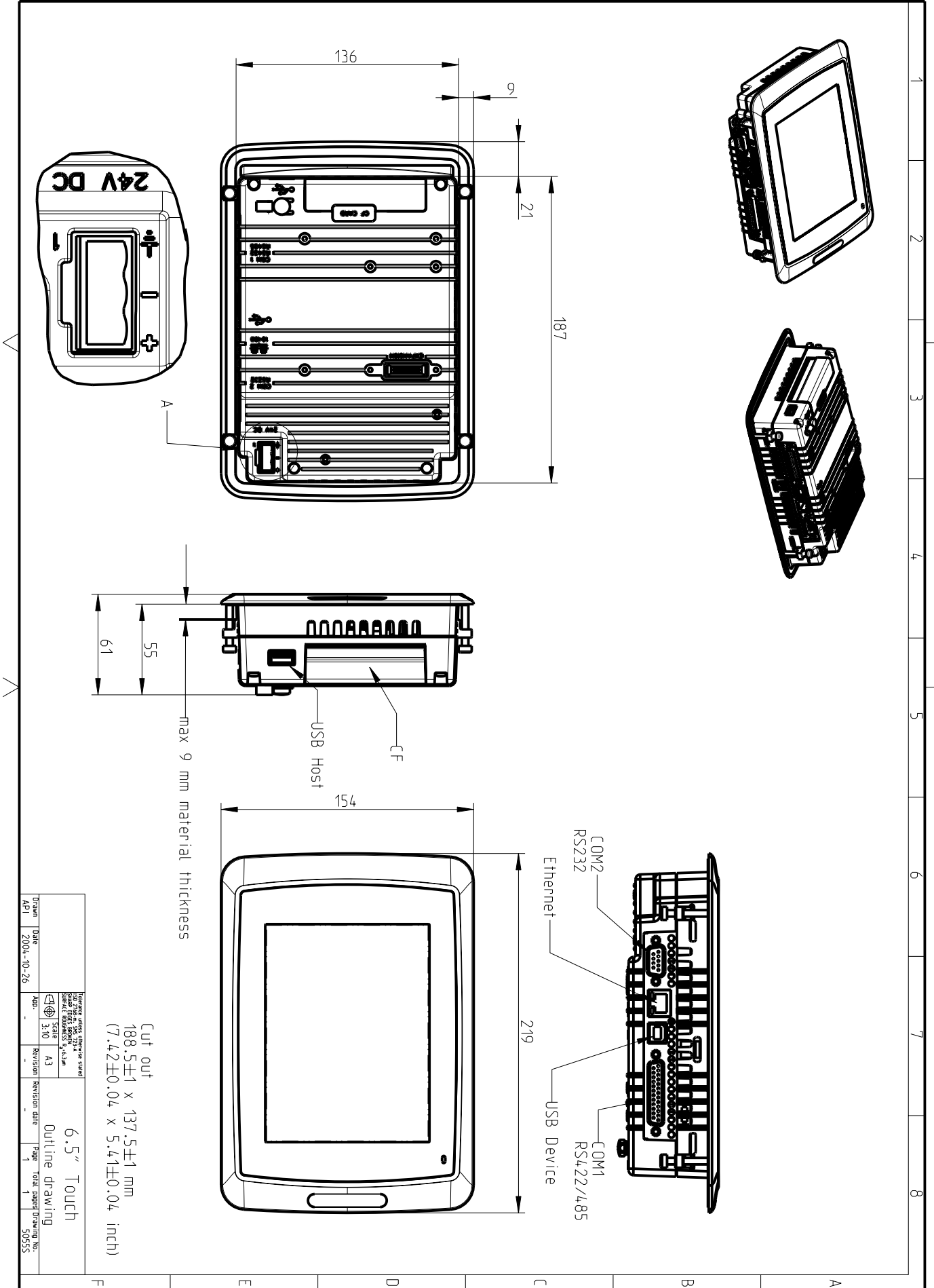

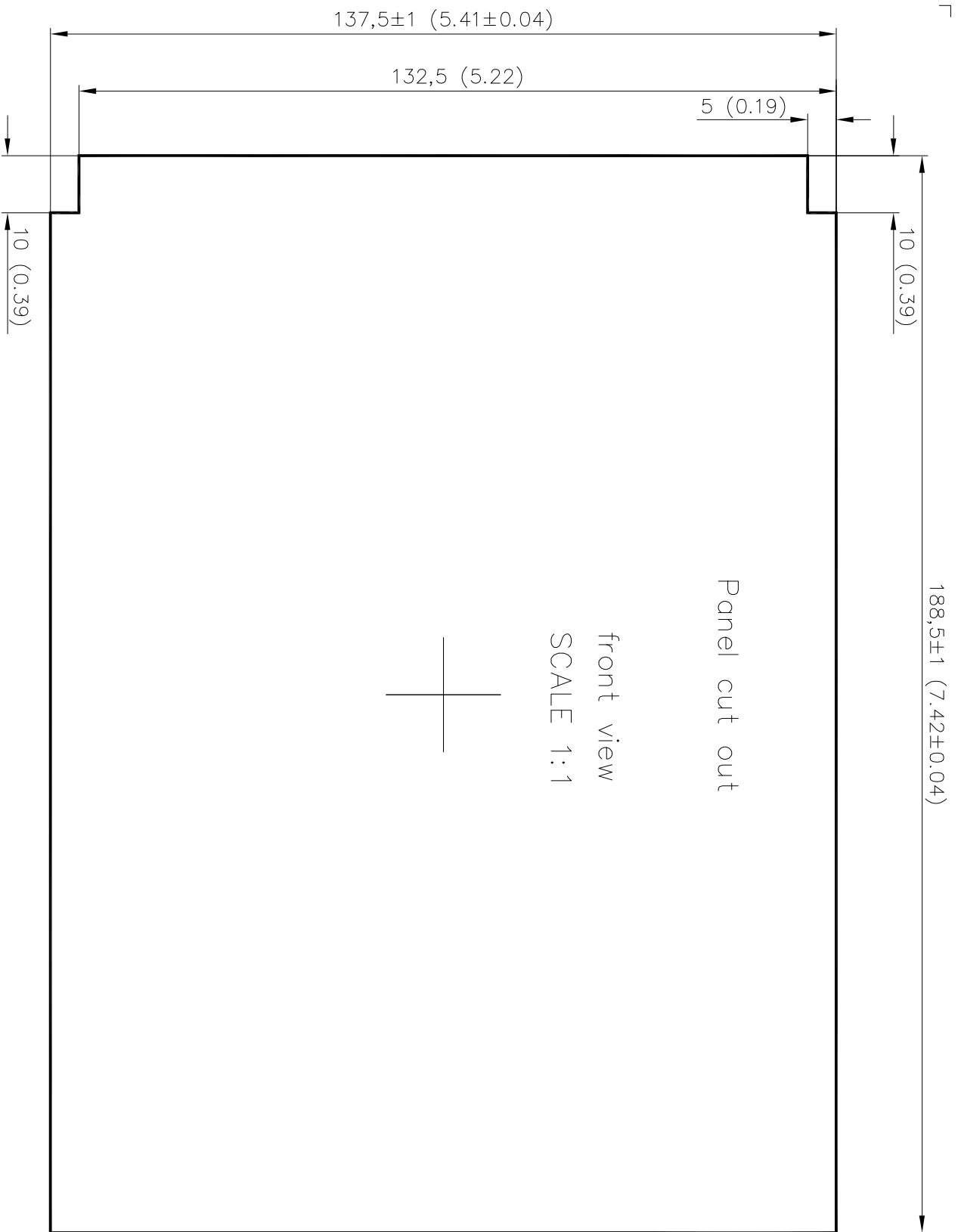



**HEADQUARTERS**

MITSUBISHI ELECTRIC EUROPE B.V. EUROPE  
German Branch  
Gothaer Straße 8  
**D-40880 Ratingen**  
Phone: +49 (0) 2102 / 486-0  
Fax: +49 (0) 2102 / 486-1120  
e mail: megfamail@meg.mee.com

MITSUBISHI ELECTRIC EUROPE B.V. FRANCE  
French Branch  
25, Boulevard des Bouvets  
**F-92741 Nanterre Cedex**  
Phone: +33 1 55 68 55 68  
Fax: +33 1 55 68 56 85  
e mail: factory.automation@framee.com

MITSUBISHI ELECTRIC EUROPE B.V. IRELAND  
Irish Branch  
Westgate Business Park, Ballymount  
**IRL-Dublin 24**  
Phone: +353 (0) 1 / 419 88 00  
Fax: +353 (0) 1 / 419 88 90  
e mail: sales.info@meir.mee.com

MITSUBISHI ELECTRIC EUROPE B.V. ITALY  
Italian Branch  
Via Paracelso 12  
**I-20041 Agrate Brianza (MI)**  
Phone: +39 039 6053 1  
Fax: +39 039 6053 312  
e mail: factory.automation@it.mee.com

MITSUBISHI ELECTRIC EUROPE B.V. SPAIN  
Spanish Branch  
Carretera de Rubí 76-80  
**E-08190 Sant Cugat del Vallés**  
Phone: +34 9 3 / 565 3160  
Fax: +34 9 3 / 589 1579  
e mail: industrial@sp.mee.com

MITSUBISHI ELECTRIC EUROPE B.V. UK  
UK Branch  
Travellers Lane  
**GB-Hatfield Herts. AL10 8 XB**  
Phone: +44 (0) 1707 / 27 61 00  
Fax: +44 (0) 1707 / 27 86 95  
e mail: automation@meuk.mee.com

MITSUBISHI ELECTRIC CORPORATION JAPAN  
Office Tower "Z" 14 F  
8-12,1 chome, Harumi Chuo-Ku  
**Tokyo 104-6212**  
Phone: +81 3 6221 6060  
Fax: +81 3 6221 6075

MITSUBISHI ELECTRIC AUTOMATION USA  
500 Corporate Woods Parkway  
**Vernon Hills, IL 60061**  
Phone: +1 847 / 478 21 00  
Fax: +1 847 / 478 22 83

**MIDDLE EAST REPRESENTATIVES**

TEXEL Electronics Ltd. ISRAEL  
Box 6272  
**IL-42160 Netanya**  
Phone: +972 (0) 9 / 863 08 91  
Fax: +972 (0) 9 / 885 24 30  
e mail: texel\_me@netvision.net.il

**EUROPEAN REPRESENTATIVES**

GEVA AUSTRIA  
Wiener Straße 89  
**AT-2500 Baden**  
Phone: +43 (0) 2252 / 85 55 20  
Fax: +43 (0) 2252 / 488 60  
e mail: office@geva.at

TEHNIKON BELARUS  
Oktjabrskaya 16/5, Ap 704  
**BY-220030 Minsk**  
Phone: +375 (0)17 / 210 4626  
Fax: +375 (0)17 / 210 4626  
e mail: tehnikon@belsonet.net

Koning & Hartman B.V. BELGIUM  
Researchpark Zellik, Pontbeeklaan 43  
**BE-1731 Brussels**  
Phone: +32 (0)2 / 467 17 44  
Fax: +32 (0)2 / 467 17 48  
e mail: info@koningenhartman.com

TELECON CO. BULGARIA  
Andrej Ljapchev Lbv. P. 21 4  
**BG-1756 Sofia**  
Phone: +359 (0) 2 / 97 44 05 8  
Fax: +359 (0) 2 / 97 44 06 1  
e mail: —

AutoCont CZECH REPUBLIC  
Control Systems s.r.o.  
Nemocnicni 12  
**CZ-702 00 Ostrava 2**  
Phone: +420 59 / 6152 111  
Fax: +420 59 / 6152 562  
e mail: consys@autocont.cz

louis poulsen DENMARK  
industri & automation  
Geminivej 32  
**DK-2670 Greve**  
Phone: +45 (0) 70 / 10 15 35  
Fax: +45 (0) 43 / 95 95 91  
e mail: lpia@lpmail.com

UTU Elektrotehnika AS ESTONIA  
Pärnu mnt.160i  
**EE-11317 Tallinn**  
Phone: +372 (0) 6 / 51 72 80  
Fax: +372 (0) 6 / 51 72 88  
e mail: utu@utu.ee

Beijer Electronics OY FINLAND  
Ansatie 6a  
**FIN-01740 Vantaa**  
Phone: +358 (0) 9 / 886 77 500  
Fax: +358 (0) 9 / 886 77 555  
e mail: info@beijer.fi

UTECO A.B.E.E. GREECE  
5, Mavrogenous Str.  
**GR-18542 Piraeus**  
Phone: +302 (0) 10 / 42 10 050  
Fax: +302 (0) 10 / 42 12 033  
e mail: sales@uteco.gr

Meltrade Ltd. HUNGARY  
Fertő Utca 14.  
**HU-1107 Budapest**  
Phone: +36 (0)1 / 431-9726  
Fax: +36 (0)1 / 431-9727  
e mail: office@meltrade.hu

SIA POWEL LATVIA  
Lienes iela 28  
**LV-1009 Riga**  
Phone: +371 784 / 22 80  
Fax: +371 784 / 22 81  
e mail: utu@utu.lv

UAB UTU POWEL LITHUANIA  
Savanoriu pr. 187  
**LT-2053 Vilnius**  
Phone: +370 (0) 52323-101  
Fax: +370 (0) 52322-980  
e mail: powel@utu.lt

**EUROPEAN REPRESENTATIVES**

INTEHSIS SRL MOLDOVA  
Cuza-Voda 36/1-81  
**MD-2061 Chisinau**  
Phone: +373 (0)2 / 562 263  
Fax: +373 (0)2 / 562 263  
e mail: intehsis@mdl.net

Koning & Hartman B.V. NETHERLANDS  
Donauweg 2 B  
**NL-1000 AK Amsterdam**  
Phone: +31 (0)20 / 587 76 00  
Fax: +31 (0)20 / 587 76 05  
e mail: info@koningenhartman.com

Beijer Electronics A/S NORWAY  
Teglverksveien 1  
**N-3002 Drammen**  
Phone: +47 (0) 32 / 24 30 00  
Fax: +47 (0) 32 / 84 85 77  
e mail: info@beijer.no

MPL Technology Sp. z o.o. POLAND  
ul. Sliczna 36  
**PL-31-444 Kraków**  
Phone: +48 (0) 12 / 632 28 85  
Fax: +48 (0) 12 / 632 47 82  
e mail: krakow@mpl.pl

Sirius Trading & Services srl ROMANIA  
Str. Biharia No. 67-77  
**RO-013981 Bucuresti 1**  
Phone: +40 (0) 21 / 201 1146  
Fax: +40 (0) 21 / 201 1148  
e mail: sirius@siriustrading.ro

INEA SR d.o.o. SERBIA AND MONTENEGRO  
Karadjordjeva 12/260  
**SCG-113000 Smederevo**  
Phone: +381 (0)26 / 617 - 163  
Fax: +381 (0)26 / 617 - 163  
e mail: inea\_sr@verat.net

AutoCont Control s.r.o. SLOVAKIA  
Radlinského 47  
**SK-02601 Dolný Kubín**  
Phone: +421 435868 210  
Fax: +421 435868 210  
e mail: info@autocontcontrol.sk

INEA d.o.o. SLOVENIA  
Stegne 11  
**SI-1000 Ljubljana**  
Phone: +386 (0) 1-513 8100  
Fax: +386 (0) 1-513 8170  
e mail: inea@inea.si

Beijer Electronics AB SWEDEN  
Box 426  
**S-20124 Malmö**  
Phone: +46 (0) 40 / 35 86 00  
Fax: +46 (0) 40 / 35 86 02  
e mail: info@beijer.se

ECONOTEC AG SWITZERLAND  
Postfach 282  
**CH-8309 Nürensdorf**  
Phone: +41 (0) 44 / 838 48 11  
Fax: +41 (0) 44 / 838 48 12  
e mail: info@econotec.ch

GTS TURKEY  
Darülaceze Cad. No. 43 Kat. 2  
**TR-80270 Okmeydani-Istanbul**  
Phone: +90 (0) 212 / 320 1640  
Fax: +90 (0) 212 / 320 1649  
e mail: gts@turk.net

CSC Automation Ltd. UKRAINE  
15, M. Raskova St., Fl. 10, Office 1010  
**UA-02002 Kiev**  
Phone: +380 (0) 44 / 494 3355  
Fax: +380 (0) 44 / 494 3366  
e mail: csc-a@csc-a.kiev.ua

**EURASIAN REPRESENTATIVES**

Kazpromautomatics Ltd. KAZAKHSTAN  
2, Scladskaya Str.  
**KAZ-470046 Karaganda**  
Phone: +7 3212 50 11 50  
Fax: +7 3212 50 11 50  
e mail: info@kpakz.com

Avtomatika Sever Ltd. RUSSIA  
Lva Tolstogo Str. 7, Off. 311  
**RU-197376 St Petersburg**  
Phone: +7 812 1183 238  
Fax: +7 812 1183 239  
e mail: as@avtsev.spb.ru

Consys RUSSIA  
Promyshlennaya St. 42  
**RU-198099 St Petersburg**  
Phone: +7 812 325 3653  
Fax: +7 812 147 2055  
e mail: consys@consys.spb.ru

Electrotechnical Systems Siberia RUSSIA  
Shetinkina St. 33, Office 116  
**RU-630088 Novosibirsk**  
Phone: +7 3832 / 119598  
Fax: +7 3832 / 119598  
e mail: info@eltechsystems.ru

Elektrostyle RUSSIA  
Poslannikov Per., 9, Str.1  
**RU-107005 Moscow**  
Phone: +7 095 542 4323  
Fax: +7 095 956 7526  
e mail: info@estl.ru

Elektrostyle RUSSIA  
Krasnij Prospekt 220-1, Office No. 312  
**RU-630049 Novosibirsk**  
Phone: +7 3832 / 106618  
Fax: +7 3832 / 106626  
e mail: info@estl.ru

ICOS RUSSIA  
Industrial Computer Systems Zao  
Ryazanskij Prospekt, 8A, Off. 100  
**RU-109428 Moscow**  
Phone: +7 095 232 0207  
Fax: +7 095 232 0327  
e mail: mail@icos.ru

NPP Uralelektra RUSSIA  
Sverdlova 11A  
**RU-620027 Ekaterinburg**  
Phone: +7 34 32 / 532745  
Fax: +7 34 32 / 532745  
e mail: elektra@etel.ru

STC Drive Technique RUSSIA  
Poslannikov Per., 9, Str.1  
**RU-107005 Moscow**  
Phone: +7 095 790 7210  
Fax: +7 095 790 7212  
e mail: info@privod.ru

**AFRICAN REPRESENTATIVE**

CBI Ltd. SOUTH AFRICA  
Private Bag 2016  
**ZA-1600 Isando**  
Phone: +27 (0) 11 / 928 2000  
Fax: +27 (0) 11 / 392 2354  
e mail: cbi@cbi.co.za