

EV 101

01.98

1

Summary

	page
• Product presentation	15
• Functions	16
• Technical specifications	17
• Pilote dimmer EV 104 associated with the EV101/EV103 dimmers single phase systems	18
• Pilote dimmer EV 104 associated with the EV101/EV103 dimmers in three phase systems	19
• Dimmer EV 101	20
• Warranty	27

2

Products presentation

EV 101 Remote control dimmer 1000 W (triac).

This remote control dimmer allows the dimming of 230V-incandescent lamps, 230V-halogen lamps, VLV-halogen lamps with ferromagnetic transformer and fluorescent tubes with electronic ballast with a $0.6 < \cos \varphi < 0.95$ up to 1000 W / VA.

When associated with a pilot dimmer EV104 or EV105 it allows the dimming of up to 30 x 1000W via a 1-10V link.

Safety Recommendations

- This product is not suitable for the dimming of electronic transformer and electronic ballasts $\cos \varphi \geq 0.95$.
- This recommendation has to be respected in order not to destroy the product.
- Check if the electronic ballast can be piloted by a remote control dimmer with triac.
- Follow the indications of light, transformer and electronic ballast manufacturers.
- When working on connected lights the remote control dimmer must be connected tension free (stressfree).
- Installation can only be effected by a specialist.
- Because of the products' power dissipation it is necessary to respect the correct size of the enclosures.

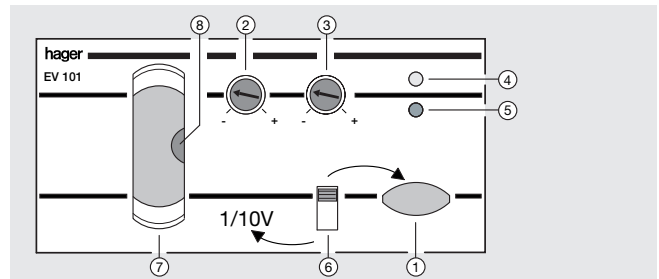

- ① Push button
- ② Min. threshold adjustment.
- ③ Max. threshold adjustment.
- ④ Power supply indicator LED.
- ⑤ Overheating indicator LED.
- ⑥ Selector switch :
 - Dimmer only
 - Dimmer controlled by EV104 or EV105
- ⑦ Fuse compartment, with spare fuse EV092 included.
- ⑧ Fuse failure indicator LED.

15

Functions

- **Light level adjustment (Switch in upper position) :**
Once connecting the product, the power indicator shines.
The light level can be set :
- either by the push button on the front of the product
- or by the associated standard and/or luminous push buttons.
ON/OFF : by brief push on the push button (similar function as a latching relay).
Brighter / Darker : By holding down on the push-button the light intensity varies. The dimming continues until it reaches the max/min value, or until the push-button is released. The dimming action is inverted by each new press of the push button.
- **Light adjustment system operation (Switch in lower position) :**
The EV101 is controlled by a pilot dimmer (EV104 or EV105) via the 1-10 V link. In this configuration the push button on the front and the push button input (terminal 7) have no function.
- **Memory function :**
Whenever the device is switched off or in the event of a power failure the lighting level is memorised.
- **Soft start :**
To increase the lamps life time, the dimmer has an integrated soft start function.
The lighting intensity is gradually increased to the required level

- **Electronical overheating protection :**
In case of overheating, the EV001 reduces automatically the release power. The lighting intensity will decrease and the yellow LED will light-up. To solve this problem :
- adapt or reduce the connected load
- decrease the temperature of the device and of the enclosure by using dissipation inserts (ex : LZ 060) and assure a good ventilation of the enclosure.
- **Limitation of the dimming range :**
MIN : lower dimming limit, rangeable from 0 % to 30 %
MAX : upper dimming limit, rangeable from 75 % to 100 %.
- **0% and 100% override :** These overrides will cancel the dimming function.
- full power override (100%)
- stop override (0%) to switched off the product.
The full power override (100%) will have priority over the stop override (0%).
- **Short circuit protection :**
In case of a short circuit of the load, a **rapid fuse** protects the dimmer. When the fuse failed, the indicator is lit. To change the fuse :
- pull out the fuse holder
- insert the spare fuse.
- **External Synchronisator :** In order to reduce the disturbances (e.g. caused by ripple control signals) it is possible to connect the synchronisation module EV009.

16

Technical specifications

● Supply	Voltage Power dissipation	230 V AC +10-15 % 50 Hz 10 W max.
● Power circuit	230 V incandescent lamps 230 V halogen lamps VLV halogen lamps with ferromagnetic transformer Fluorescent tubes with electronic ballast $0.6 < \cos \varphi < 0.95$	100 W to 1000 W 100 W to 1000 W 100 VA to 1000 VA (take the efficiency of the transformers to calculate the maximum number of controlled lamps into account) 100 to 1000 VA
● Increasing the capacity	With pilot dimmer EV 104 or EV 105 Pilot input Distance of connection	up to 30 x EV 101 and/or EV 103 IN 1/10 V 50 m max.
● Push button input	Voltage Distance of connection Push button with pilot light	230 V AC +10-15 % 50 Hz 50 m max. rest current : 10 mA max.
● 0 %, 100 % Override input	By voltfree contact. Voltage Distance of connection	230 V AC +10-15 % 50 Hz 50 m max.
● Protections	Overheating Short circuit of the load	electronical, self-resetting rapid fuse 5 x 20 mm F 5A H 250 V
● Connection	Cable clamps	flexible : 1 to 6 mm ² rigid : 1,5 to 10 mm ²
● Environment	Operation Storage	-5 °C to +40 °C (10 à 90% relative ambient humidity) -20 °C to +70 °C (5 à 90% relative ambient humidity)
● Mounting	On DIN rails according to EN 50022	size : 5 modules H = 85 x W = 87,5 x D = 58

17

Pilot dimmer EV 104 associated with the EV 101 dimmers for single phase systems

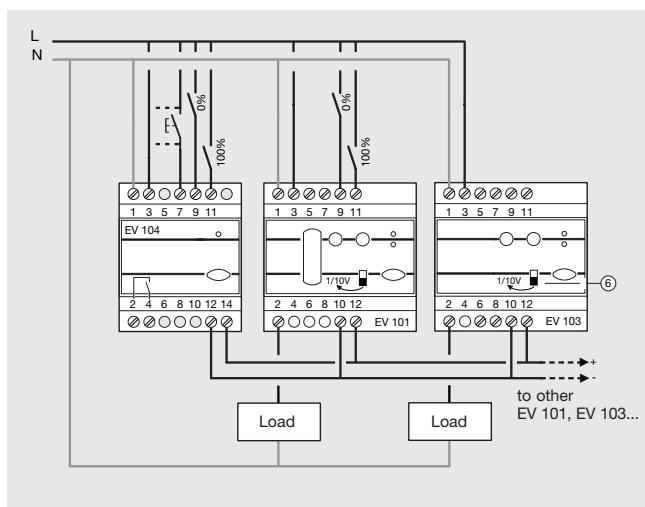

- The EV 105 overrides the EV 101 / EV 103
- The selector switch ⑥ of the EV 101 and / or EV 103 has to be in the down position (1-10 V).
In this configuration the push button on the front face and the push button input (terminal 7) will not function.

18

Pilot dimmer EV 104 associated with the EV 101/EV 103 dimmers in three phase systems

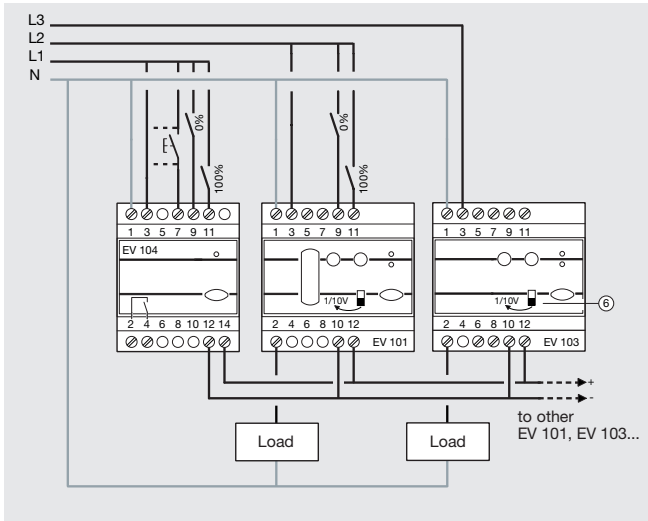

- The EV 104 overrides the EV 101 / EV 103
- The selector switch ⑥ of the EV 101 and/or EV 103 has to be in the down position (1-10 V). In this configuration the push button on the front face and the push button input (terminal 7) will not function.

19

Dimmer EV 101 :

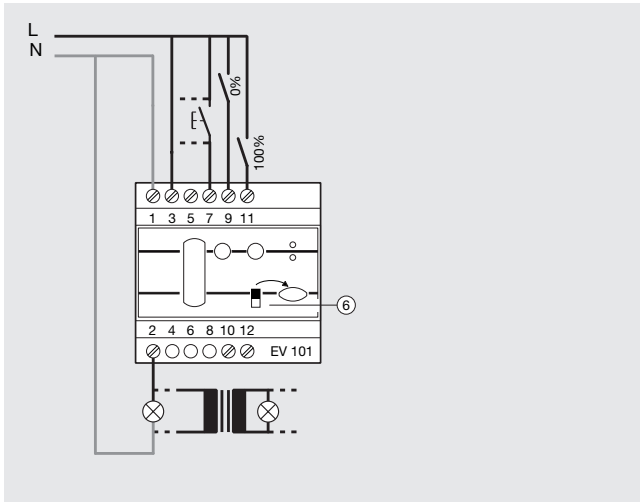

- VLV halogen lamps with **ferromagnetic transformers**. The transformer shouldn't be used with less than 50 % of its nominal load.
example : a power transformer of 500W has to control a minimum load of 250 W.
- The selector switch ⑥ has to be in the up position.
- Note : the minimum load of the EV 101 : 100 W.
- Fluorescent lamps with **electronical ballast** ($0.6 < \cos \varphi < 0.95$).
a) Adjustment of the lighting threshold value : (Min threshold)
Put the potentiometer ② into medium position.
Adjust the remote control dimmer to ist minimum dim value.
Turn potentiometer into the direction decrease until the minimum value of the fluorescent lamp is found.

20

Warranty



A warranty period of 24 months is offered on hager products, from date of manufacture, relating to any material of manufacturing defect. If any product is found to be defective it must be returned via the installer and supplier (wholesaler). The warranty is withdrawn if :

- after inspection by hager quality control dept the device is found to have been installed in a manner wich is contrary to IEE wiring regulations and accepted practice within the industry at the time of installations.
 - the procedure for the return of goods has not been followed.
- Explanation of defect must be included when returning goods.