

SJDE-□-OY, SJME-□-OY

Junma Servo system

**A new concept in drive simplicity
Save space, save wiring, save time**

- Ultra compact drive size reduces panel space
- Tuning-less technology, no gain parameters need to be set
- Peak torque 300% of nominal for 3 seconds
- High response, high speed, high torque and high accuracy
- Drive version with MECHATROLINK-II port built-in
- MECHATROLINK-II simplifies wiring and reduces installation time
- MECHATROLINK-II provides access to the system from one point
- Pulse control Drive version available, fully "Parameter-less" just plug and run



Ratings

- 230 VAC Single-phase 100 W to 750 W (2.39 Nm)

System Configuration

Junma MECHATROLINK-II Servo Drive Configuration

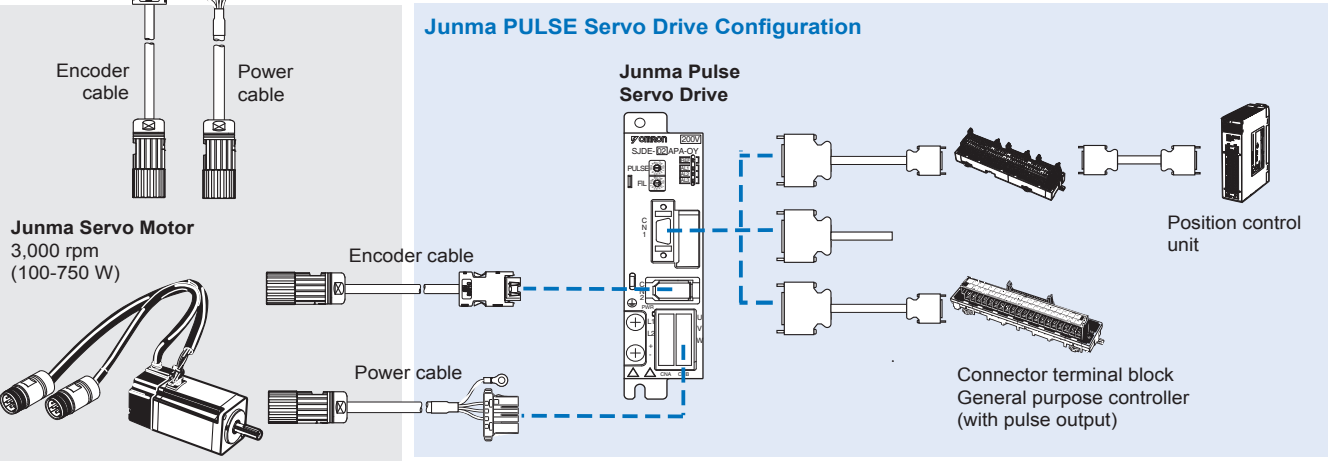
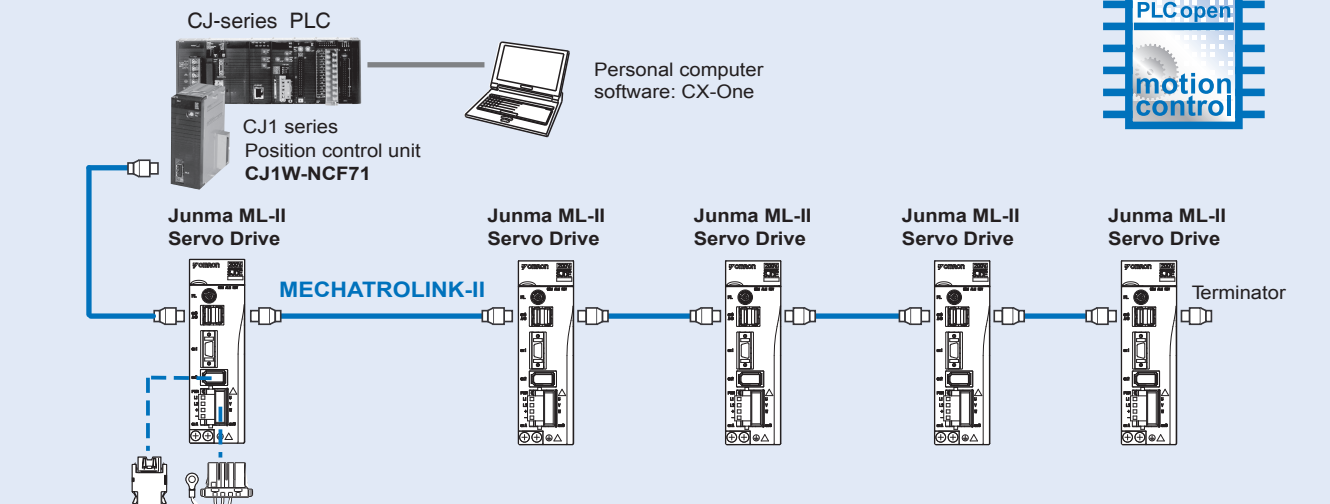

Motor Type Designation

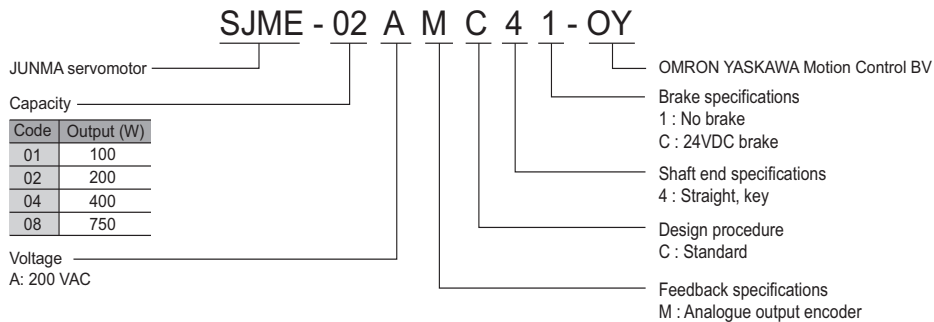

Servomotor Specifications

Voltage		230 V			
Servomotor Model SJME- □		01A□	02A□	04A□	08A□
Rated Output ¹	W	100	200	400	750
Rated Torque ^{1, 2}	N·m	0.318	0.637	1.27	2.39
Instantaneous Peak Torque ¹	N·m	0.955	1.91	3.82	7.16
Rated Current ¹	Arms	0.84	1.1	2.0	3.7
Instantaneous Max. Current ¹	Arms	2.5	3.3	6.0	11.1
Rated Speed ¹	min ⁻¹	3000			
Max. Speed ¹	min ⁻¹	4500			
Torque Constant	N·m/Arms	0.413	0.645	0.682	0.699
Rotor Moment of Inertia (JM)	kg·m ² ×10 ⁻⁴	0.0634	0.330	0.603	1.50
Allowable load inertia ³	kg·m ² ×10 ⁻⁴	0.6	3.0	5.0	10.0
Rated Power Rate	kW/s	16.0	12.3	26.7	38.1
Rated Angular Acceleration	rad/s ²	50200	19300	21100	15900
Encoder	Standard	Analogue output encoder			
Allowable radial load		78	245	245	392
Allowable thrust load		54	74	74	147
Approx. mass	kg (without brake)	0.5	0.9	1.3	2.6
	kg (with brake)	0.8	1.5	1.9	3.5
Brake specifications	Rated voltage	24 VDC ±10%			
	Holding Brake Moment of Inertia	kg·m ² ×10 ⁻⁴	0.0075	0.064	0.171
	Power consumption (at 20°C)	W	6	6.9	7.7
	Current consumption (at 20°C)	A	0.25	0.29	0.32
	Static friction torque	N·m (minimum)	0.318	1.27	2.39
	Rise time for holding torque	ms (max)	100		
Release time	ms (max)	80			
Basic Specifications	Time Rating	Continuous			
	Thermal Class	Class B			
	Vibration Class	15 μm or below			
	Withstand Voltage	1500 VAC for one minute			
	Insulation resistance	500 VDC, 10 MΩ min.			
	Enclosure	Totally-enclosed, self-cooled, IP55 (excluding shaft opening and connectors)			
	Vibration Resistance	Vibration acceleration 49 m/s ²			
	Usage / storage temperature	0 to +40°C / -20 to 60°C without freezing			
	Usage / storage humidity	20 to 80% RH (non-condensing)			
	Altitude	1000 m or less above sea level			
Mounting	Flange-mounted				

Note: *1. These items and speed/torque characteristics quoted in combination with an SJDE servo drive are at an armature winding temperature of 100°C. Other values quoted at 20°C.
 *2. The rated torques listed here are the values for the continuous allowable torque at 40°C with an aluminium heatsink (250 mm x 250 mm x 6 mm) attached.
 *3. Value use the appropriate SJDE drive without of external regeneration unit

Torque-Speed Charecteristics

(A : Continuous Duty Zone B : Intermittent Duty Zone)

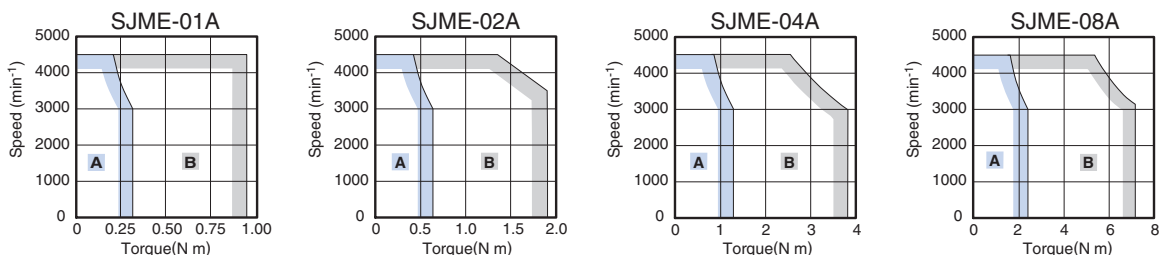

Servomotor / Servo Drive Combination

Junma Servomotor				Junma servo drive			
	Voltage	Rated Torque	Capacity	Model without brake	Model with brake	MECHATROLINK-II	Pulse Control
	200 V	0.318 Nm	100 W	SJME-01AMC41-OY	SJME-01AMC4C-OY	SJDE-01ANA-OY	SJDE-01APA-OY
		0.637 Nm	200 W	SJME-02AMC41-OY	SJME-02AMC4C-OY	SJDE-02ANA-OY	SJDE-02APA-OY
		1.27 Nm	400 W	SJME-04AMC41-OY	SJME-04AMC4C-OY	SJDE-04ANA-OY	SJDE-04APA-OY
		2.39 Nm	750 W	SJME-08AMC41-OY	SJME-08AMC4C-OY	SJDE-08ANA-OY	SJDE-08APA-OY

Servo Drive Type Designation

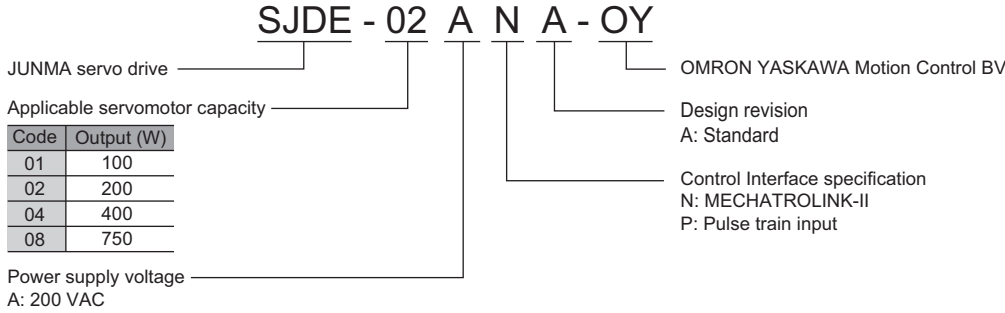

Servo Drive Specifications

Junma MECHATROLINK-II Servo Drive

Servo Drive Type	SJDE-□	01ANA-OY	02ANA-OY	04ANA-OY	08ANA-OY	
Applicable servomotor	SJME-□	01A□	02A□	04A□	08A□	
Basic specifications	Max. Applicable Motor capacity	W	100	200	400	750
	Continuous output current	Arms	0.84	1.1	2.0	3.7
	Max. output current	Arms	2.5	3.3	6.0	11.1
	Input power supply (Main circuit and control circuit)	Voltage	Single-phase, 200 to 230 VAC, + 10 to -15% (50/60 Hz)			
		Capacity KVA	0.40	0.75	1.2	2.2
	Control Method	PWM control, sine wave current drive system				
	Feedback	Analogue incremental encoder (13 bits incremental equivalent)				
	Allowable load inertia ¹	kg·m ²	0.6 × 10 ⁻⁴	3.0 × 10 ⁻⁴	5.0 × 10 ⁻⁴	10.0 × 10 ⁻⁴
	Usage / storage temperature	0 to +55 °C / -20 to 70 °C				
	Usage / storage humidity	90%RH or less (non-condensing)				
	Altitude	1000m or less above sea level				
	Vibration/shock Resistance	4.9m/s ² (0.5G) / 19.6m/s ² (2G)				
	Configuration	Base mounted				
	Approx. mass	Kg	1.0			1.4
Built-in functions	Dynamic brake (DB)	Operated at main power OFF, servo alarm, servo OFF.(OFF after motor stops; ON when motor power is off.)				
	Regenerative processing	Optional (If the regenerated energy is too large, install a regenerative unit JUSP-RG08D)				
	Over-travel (OT) prevention function	P_OT, N_OT				
	Emergency stop	Emergency stop (E-STP)				
	LED display	4 LEDs (PWR, RDY, COM, ALM)				
	MECHATROLINK-II monitor	MECHATROLINK-II under communication : COM LED (Light ON)				
	Servo ON/OFF monitor	At Servo OFF : RDY LED (Light OFF), at Servo ON : RDY LED (Light Blinks)				
	Power supply status monitor	Control / main-circuit power-supply OFF state: PWR LED (Light OFF) Control / main-circuit power-supply ON state: PWR LED (Light ON)				
	Electronic gearing	0.01 < A/B < 100				
	Protection	Overcurrent, overvoltage, undervoltage, overload, main circuit sensor error, board temperature error, excessive position error overflow, overspeed, encoder signal error, overrun protection, system error, parameter error				
	MECHATROLINK Communication	Comm. protocol	MECHATROLINK-II			
		Transmission rate	10 Mbps			
		Transmission cycle	1ms, 1.5ms, 2ms, 3ms, 4ms			
		Data length	17 byte and 32 byte			
Command input	MECHATROLINK communication	MECHATROLINK-II commands (For sequence, motion, data setting/reference, monitor, adjustment, and other commands)				
Sequence Input signal	Fixed input	5 points (fixed layout: external latch signal, zero return reduced speed signal, forward drive inhibiting signal, reverse run inhibiting signal, emergency stop signal)				
Sequence Output signal	Fixed output	2 points (fixed layout: servo alarm, brake interlock)				

Note: *1. Value without external regeneration unit

Junma Pulse Servo Drives

Servo Drive Type	SJDE-□	01APA-OY	02APA-OY	04APA-OY	08APA-OY	
Applicable servomotor	SJME-□	01A□	02A□	04A□	08A□	
Basic specifications	Max. Applicable Motor capacity	W	100	200	400	750
	Continuous output current	Arms	0.84	1.1	2.0	3.7
	Max. output current	Arms	2.5	3.3	6.0	11.1
	Input power supply (Main circuit and control circuit)	Voltage	Single-phase, 200 to 230 VAC, + 10 to -15% (50/60 Hz)			
		Capacity KVA	0.40	0.75	1.2	2.2
	Control Method	PWM control, sine wave current drive system				
	Feedback	Analogue incremental encoder (10000 steps per revolution)				
	Allowable load inertia ¹	kg·m ²	0.6 × 10 ⁻⁴	3.0 × 10 ⁻⁴	5.0 × 10 ⁻⁴	10.0 × 10 ⁻⁴
	Usage / storage temperature	0 to +55° C / -20 to 70° C				
	Usage / storage humidity	90%RH or less (non-condensing)				
	Altitude	1000 m or less above sea level				
	Vibration/shock Resistance	4.9m/s ² (0.5G) / 19.6m/s ² (2G)				
	Configuration	Base mounted				
	Cooling method	Forced cooling (built-in fan)				
	Approx. mass	Kg	0.5			1.0
Built-in functions	Dynamic brake (DB)	Operated at main power OFF, servo alarm, servo OFF.(OFF after motor stops; ON when motor power is off.)				
	Regenerative processing	Optional (If the regenerated energy is too large, install a regenerative unit JUSP-RG08D)				
	LED display	5 (PWE, REF, AL1, AL2, AL3)				
	Reference filter	Select one of eight levels with FIL switch				
Protection	Speed errors, overload, encoder errors, voltage errors, overcurrents, disablement of the built-in cooling fan, system errors					
I/O Signals	Input signal for reference Designated pulse type and pulse resolution with PULSE switch.	Pulse type	Select one of the following signals: 1. CCW + CW 2. Sign + pulse train 3. CCW + CW (logic reversal) 4. Sign + pulse train (logic reversal)			
		Pulse resolution	Select one of the following signals: 1. 1000 pulses/rev (Open collector/line driver) 75 kpps max. 2. 2500 pulses/rev (Open collector/line driver) 187.5 kpps max. 3. 5000 pulses/rev (Line driver) 375 kpps max. 4. 10000 pulses/rev (Line driver) 750 kpps max.			
	Clear input signal	Clears the positioning error when turned ON				
	Servo ON input signal	Turns the servomotor ON or OFF				
	Alarm output signal	OFF if an alarm occurs. (Note: OFF for 2s when power is turned ON)				
	Brake output signal	External signal to control brakes. Turn ON to release the brake				
	Positioning completed output signal	ON if the current position is equal to the reference position ±10 pulses.External signal to control brakes.				
Origin output signal	ON if the motor is at the origin. (Width: 1/500 rev) (Note:Use the pulse edge that changes the signal from OFF to ON)					

Note: *1. Value without external regeneration unit

Dimensions

Junma servomotors

SJME-01 (200V, 100W)

Model	L	LL	Approx. Mass (kg)
SJME-01AMC41-OY	119	94	0.5
SJME-01AMC4C-OY	164	139	0.8

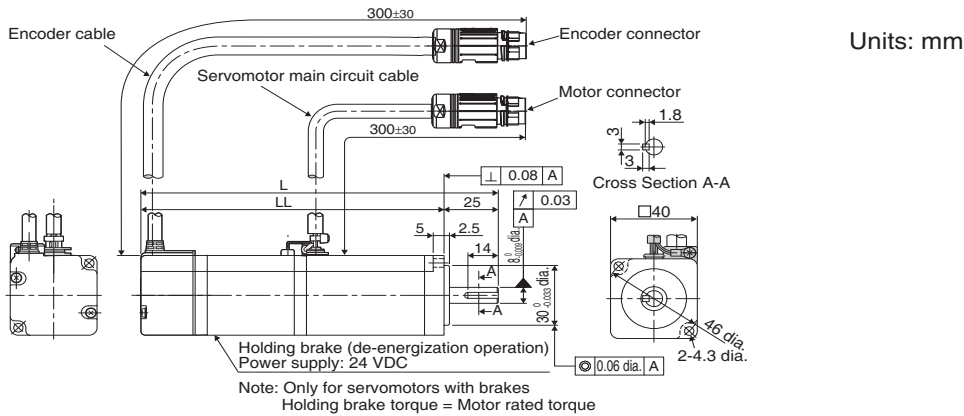

SJME-02, 04, 08 (200V, 200 to 750W)

Model	L	LL	LR	LG	LE	S	LB	LC	LD	LF	LA	LZ	QK	Approx. Mass (kg)	
SJME-02AMC41-OY	125.5	95.5	30	6	3	14 ⁰ _{-0.011}	50 ⁰ _{-0.039}	60	-	-	70	5.5	20	0.9	
SJME-02AMC4C-OY	165.5	135.5												1.5	
SJME-04AMC41-OY	148.5	118.5												1.3	
SJME-04AMC4C-OY	188.5	158.5												1.9	
SJME-08AMC41-OY	173	133	40	8	3	16 ⁰ _{-0.011}	70 ⁰ _{-0.046}	80	35	20	90	7	30	2.6	
SJME-08AMC4C-OY	216	176													3.5

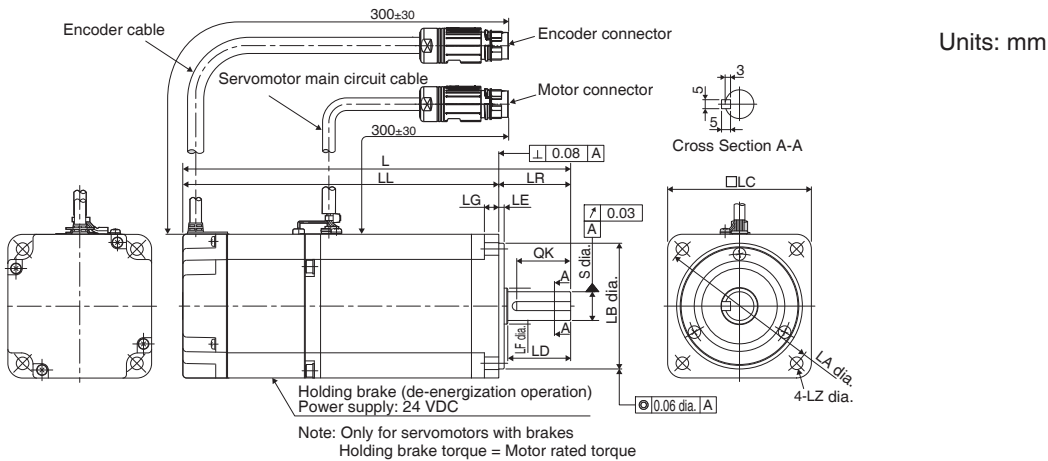

Servomotor connectors

Encoder Connector Specifications

Model: AKUA047NN0084151A000
 Male Contact (Crimp): 61.004.11
 (Manufacture: INTERCONTEC)

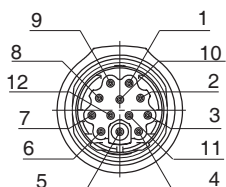

1	PG5V	Red
2	PG0V(GND)	Black
3	Phase A+	Blue
4	Phase A-	Blue/White
5	-	-
6	Phase B+	Yellow
7	Phase B-	Yellow/White
8	Phase Z	Purple
9	Phase U	Gray
10	Phase V	Green
11	Phase W	Orange
12	-	-
Case	FG	Shield wire

Motor Connector Specifications

Model: BKUA854NN0085155A000
 Male Contact (Solder): 61.006.11
 (Manufacture: INTERCONTEC)

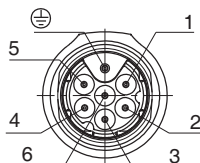

	No brake		With brake	
1	Phase U	Red	Phase U	Red
2	Phase V	White	Phase V	White
3	Phase W	Blue	Phase W	Blue
4	-	-	Brake	Red
5	-	-	Brake	Black
6	-	-	-	-
⊕	FG	Green/Yellow	FG	Green/Yellow

Junma MECHATROLINK-II servo drives

SJDE-01, 02, 04ANA-OY (200V, 100 to 400W)

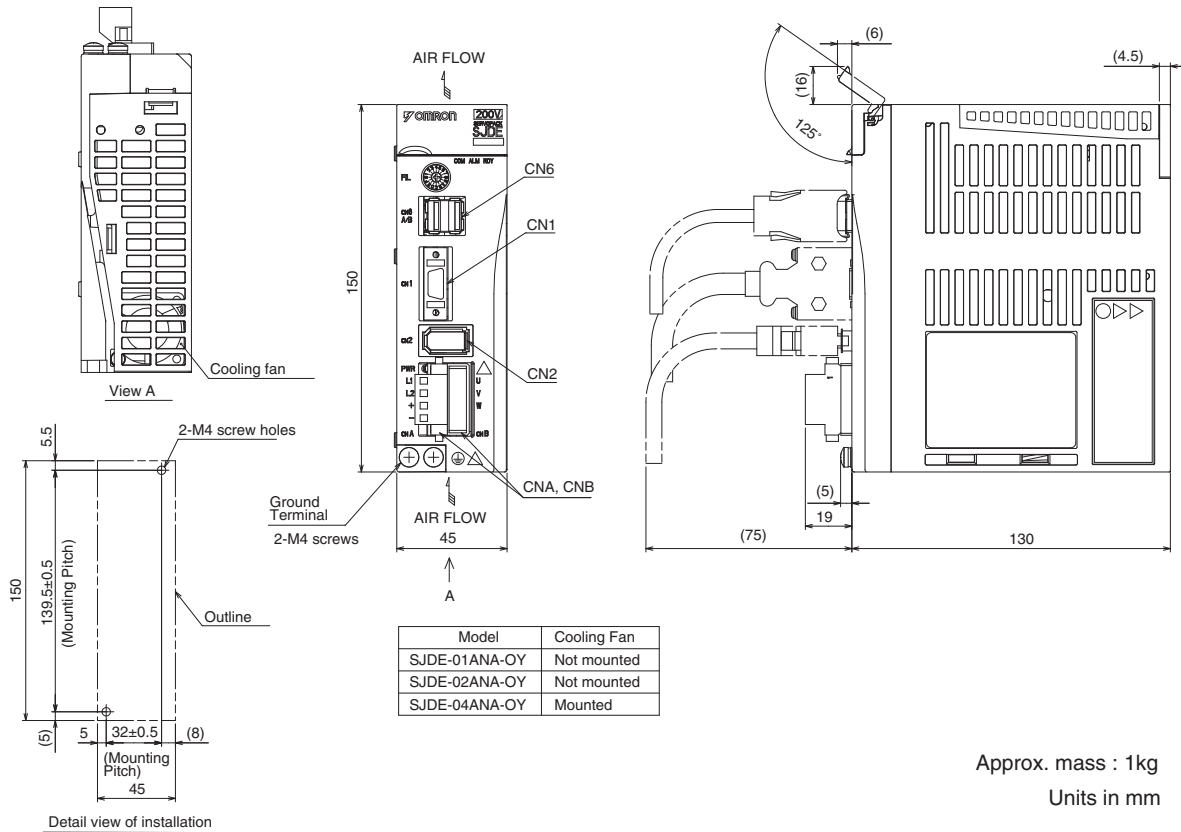

SJDE-08ANA-OY (200V, 750W)

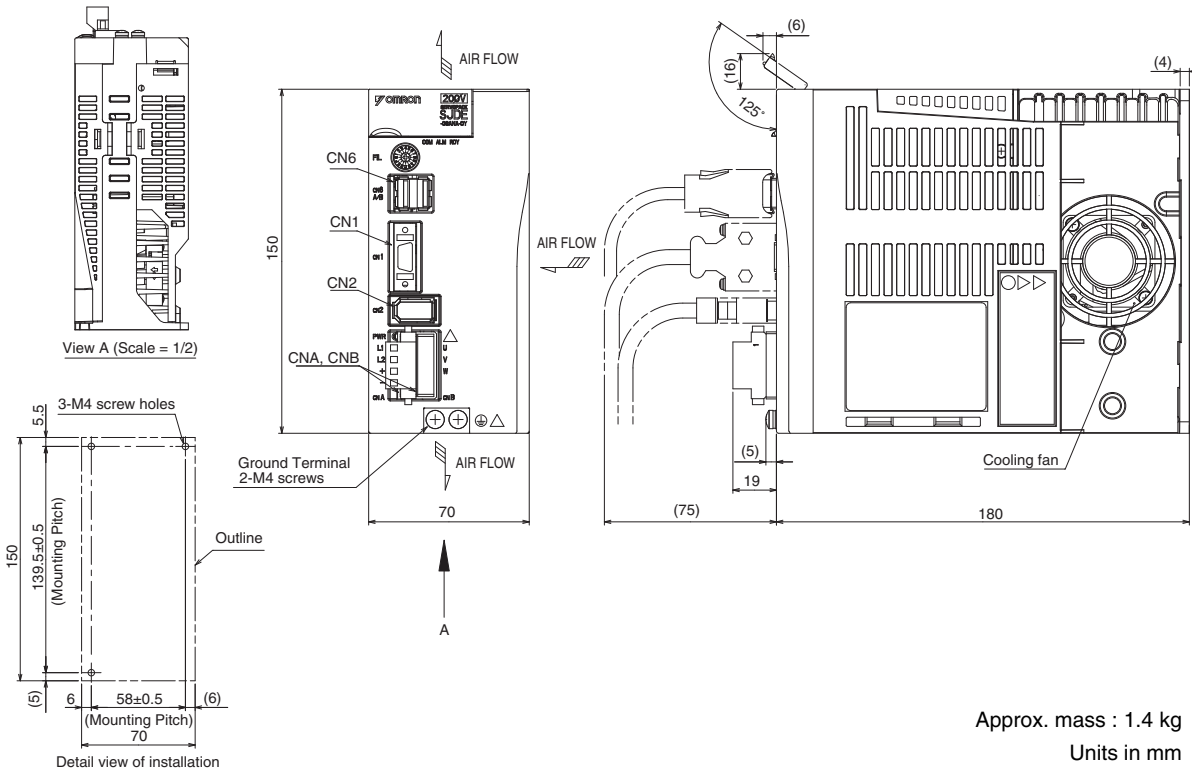

Junma pulse control servo drives

SJDE-01, 02APA-OY (200V, 100 to 200W)

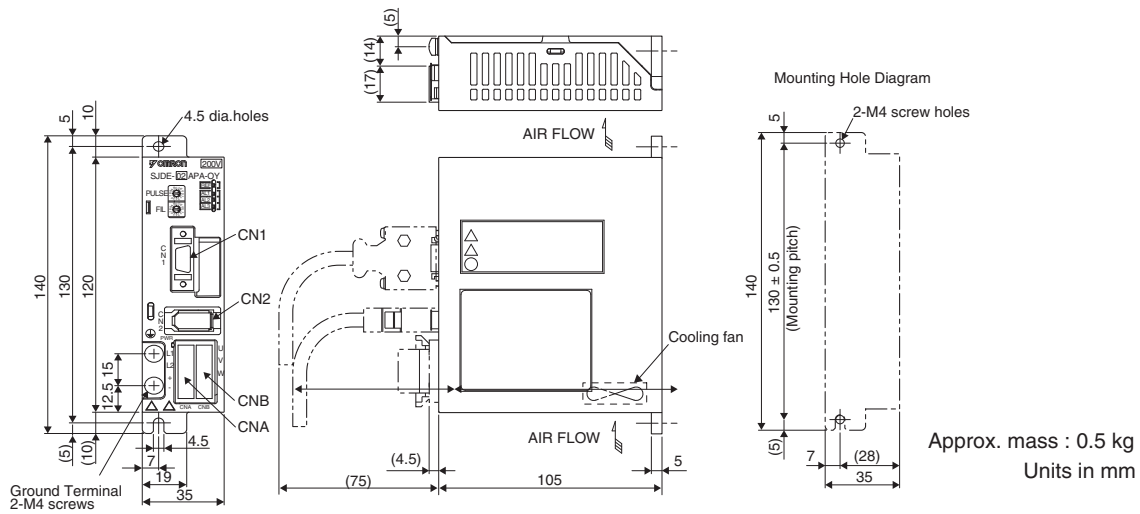

SJDE-04APA-OY (200V, 400W)

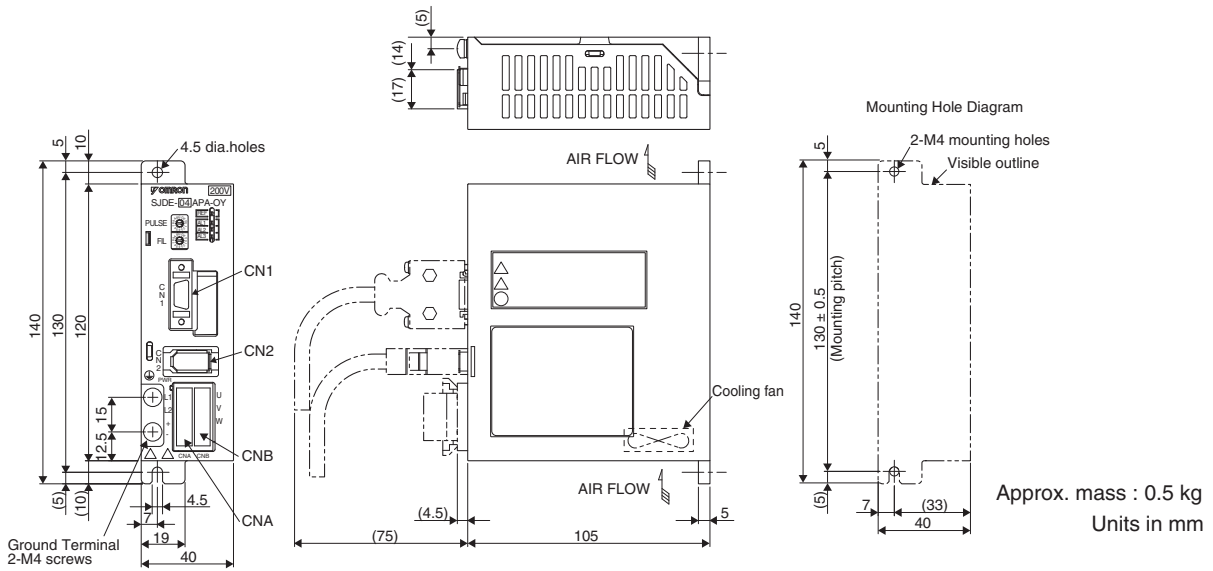

SJDE-08APA-OY (200V, 800W)

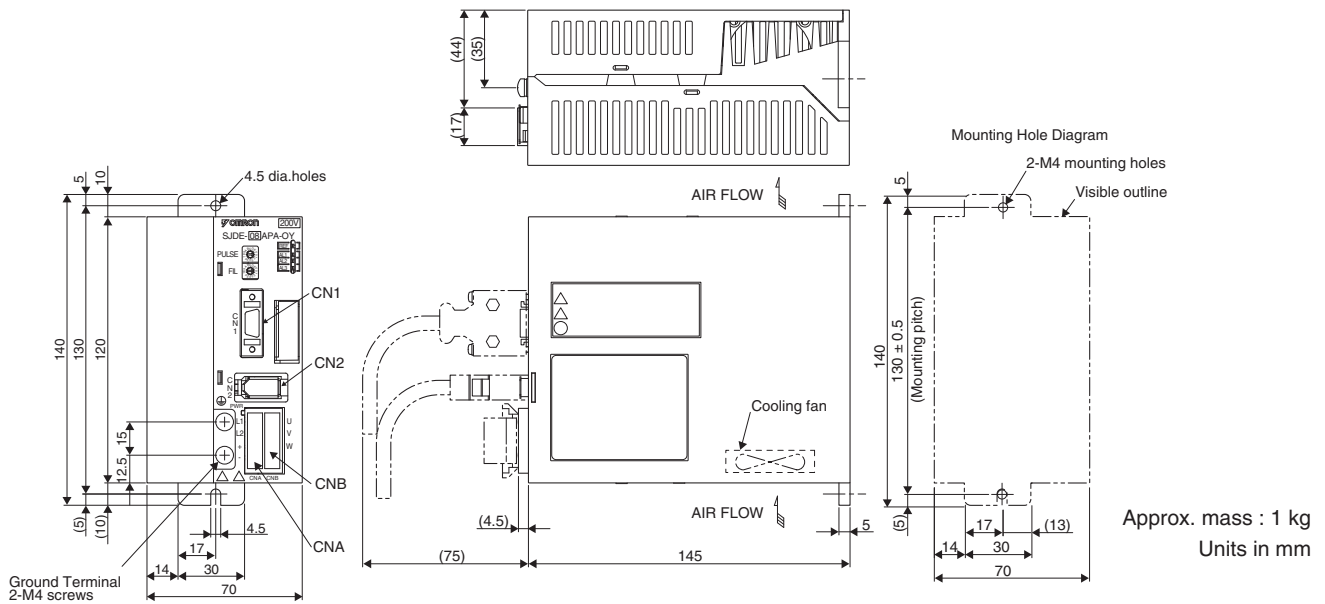

Ordering Information

Junma Servo Motor configuration

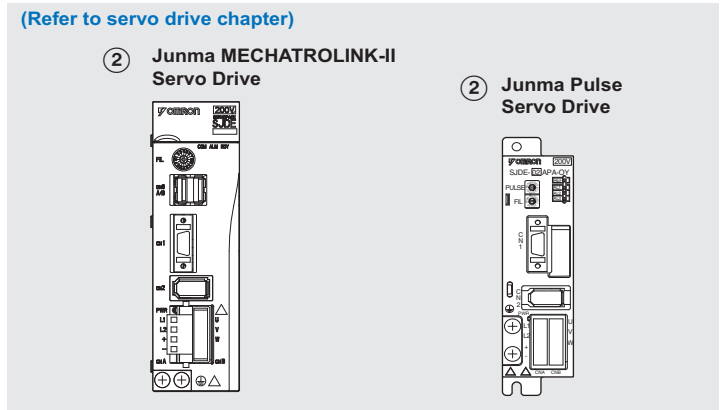
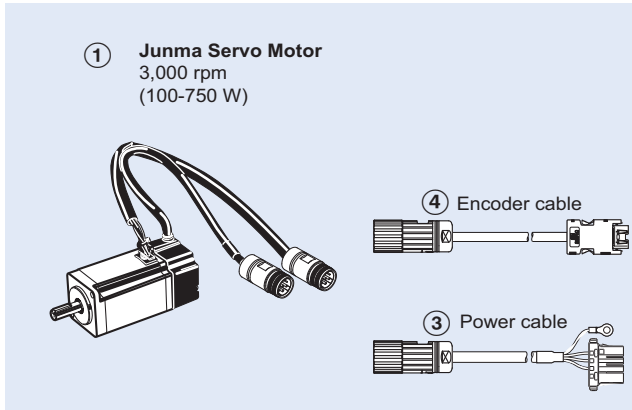

Servomotors and Servo drives

Symbol	Specifications				① Servomotor model		② Servo drive model	
	Voltage	Encoder and Design		Rated Torque	Capacity	Mechatrolink-II		Pulse Control
①②	1 Phase 200 VAC	Analogue Incremental Encoder	Without brake	0.318 Nm	100 W	SJME-01AMC41-OY	SJDE-01ANA-OY	SJDE-01APA-OY
				0.637 Nm	200 W	SJME-02AMC41-OY	SJDE-02ANA-OY	SJDE-02APA-OY
				1.27 Nm	400 W	SJME-04AMC41-OY	SJDE-04ANA-OY	SJDE-04APA-OY
				2.39 Nm	750 W	SJME-08AMC41-OY	SJDE-08ANA-OY	SJDE-08APA-OY
		Straight shaft with key	With brake	0.318 Nm	100 W	SJME-01AMC4C-OY	SJDE-01ANA-OY	SJDE-01APA-OY
				0.637 Nm	200 W	SJME-02AMC4C-OY	SJDE-02ANA-OY	SJDE-02APA-OY
				1.27 Nm	400 W	SJME-04AMC4C-OY	SJDE-04ANA-OY	SJDE-04APA-OY
				2.39 Nm	750 W	SJME-08AMC4C-OY	SJDE-08ANA-OY	SJDE-08APA-OY

Power cables

Symbol	Specifications	Model	Appearance	
③	Power cable for Junma servomotors without brake SJME-0□AMC41-OY	Flexible cables (Standard)		
		Shielded Cable		
		Bending radius (Dynamic) > 10xDiameter		
		Bending cycles > 5 Million		
	Power cable for Junma servomotors with brake SJME-0□AMC4C-OY	Flexible cables (Standard)		
		Shielded Cable		
		Bending radius (Dynamic) > 10xDiameter		
		Bending cycles > 5 Million		

Encoder cables

Symbol	Specifications	Model (Flexible)	Appearance
④	Encoder cable for Junma servomotors SJME-0□AMC4□-OY	Flexible cables (Standard)	
		Shielded Cable	
		Bending radius (Dynamic) > 10xDiameter	
		Bending cycles > 5 Million	

Connectors for power and encoder cables

Specifications			Model (Omron)
Connectors for making power cables	Drive side (CNB)	Manufacturer: JST (04JFAT-SAYGF-N)	R7A-CN201A
	Motor side	Manufacturer: Intercontec	R7A-CN202A-ME
Connectors for making encoder cables	Drive side (CN2)	Manufacturers 3M and Molex	R7A-CN201R
	Motor side	Manufacturer: Intercontec	R7A-CN202R-ME
Power connector male motor side		Manufacturer: Intercontec	R7A-CN202AM-ME
Encoder connector male motor side		Manufacturer: Intercontec	R7A-CN202RM-ME

Junma MECHATROLINK-II Servo Drive Configuration

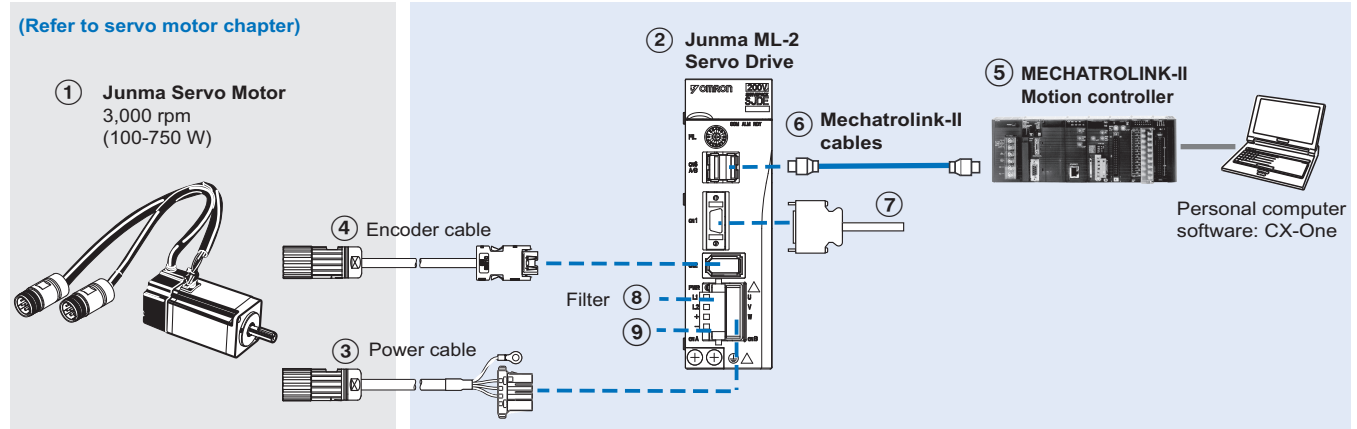

Servomotors and Servo drives

Symbol	Specifications				① Servomotor model	② Servo drive model	
	Voltage	Encoder and Design		Rated Torque			Capacity
①②	1 Phase 200 VAC	Analogue Incremental Encoder	Without brake	0.318 Nm	100 W	SJME-01AMC41-OY	SJDE-01ANA-OY
				0.637 Nm	200 W	SJME-02AMC41-OY	SJDE-02ANA-OY
				1.27 Nm	400 W	SJME-04AMC41-OY	SJDE-04ANA-OY
				2.39 Nm	750 W	SJME-08AMC41-OY	SJDE-08ANA-OY
		Straight shaft with key	With brake	0.318 Nm	100 W	SJME-01AMC4C-OY	SJDE-01ANA-OY
				0.637 Nm	200 W	SJME-02AMC4C-OY	SJDE-02ANA-OY
				1.27 Nm	400 W	SJME-04AMC4C-OY	SJDE-04ANA-OY
				2.39 Nm	750 W	SJME-08AMC4C-OY	SJDE-08ANA-OY

Power and encoder cables

Note: ③④ Refer to the Junma servo motor section for motor cables or connectors selection

Mechatrolink-II Motion controllers

Symbol	Name	Model
⑤	Position Controller Unit for CJ1 PLC	CJ1W-NCF71
	Position Controller Unit for CS1 PLC	CS1W-NCF71
	Trajexia stand-alone motion controller	TJ1-MC16

Connectors

Specification	Model (Omron)	Model (Yaskawa)
Control I/O connector (for CN1)	R7A-CNA01R	JZSP-CHI9-1
Power input connector (for CNB). (Included in drive the box)	R7A-CNZ01P	JZSP-CHG9-1

Computer Software

Specifications	Model
Configuration and monitoring software tool via ML2 (CX-Drive version 1.3 or higher)	CX-DRIVE
Complete Omron software package including CX-Drive (CX-One 2.0 or higher)	CX-ONE

Mechatrolink-II cables

Symbol	Specifications		Model	
⑥	Mechatrolink-II Terminator resistor		JEPMC-W6022	
	Mechatrolink-II Cables		0.5 m	JEPMC-W6003-A5
			1 m	JEPMC-W6003-01
			3 m	JEPMC-W6003-03
			5 m	JEPMC-W6003-05
			10 m	JEPMC-W6003-10
			20 m	JEPMC-W6003-20
			30 m	JEPMC-W6003-30

Cables for I/Os (for CN1)

Symbol	Name	Compatible units		Model
⑦	Control cable	Cable for servo drive I/O signals	1 m	R7A-CPZ001S or JZSP-CHI003-01
			2 m	R7A-CPZ002S or JZSP-CHI003-02
			3 m	JZSP-CHI003-03

Filters

Symbol	Applicable servo drive	Rated current	Leakage current	Rated voltage	Filter model
⑧	SJDE-01ANA-OY	5A	1.7 mA	250 VAC 1-phase	R7A-FIZN105-BE
	SJDE-02ANA-OY				
	SJDE-04ANA-OY				
	SJDE-08ANA-OY	9A	1.7 mA		R7A-FIZN109-BE

Regenerative Unit Model (Option)

Symbol	Specifications	Model (Omron)	Model (Yaskawa)
⑨	External regenerative unit (Optional)	R88A-RG08UA	JUSP-RG08D

Junma Pulse Servo Drive Configuration

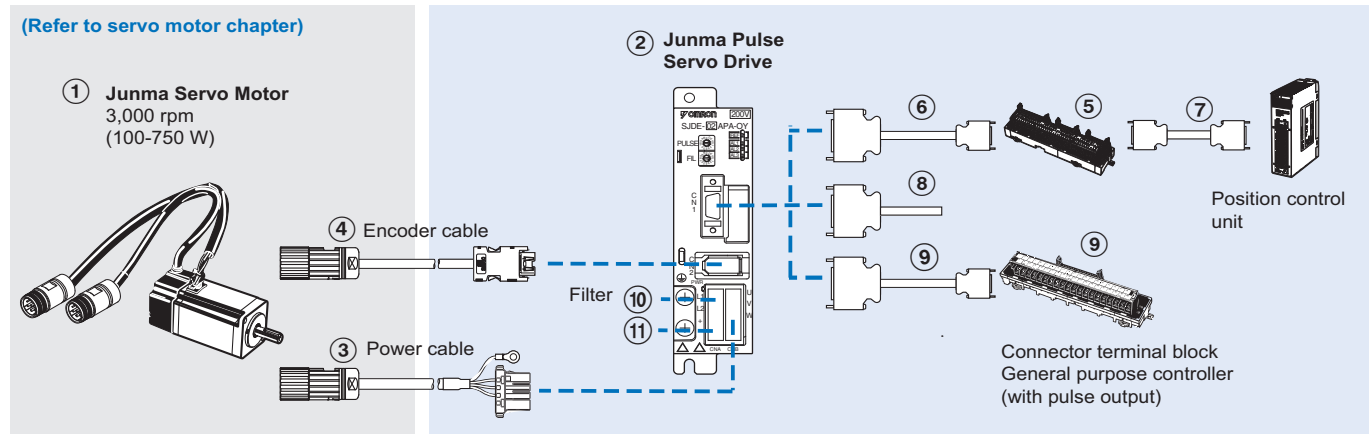

Servomotors and Servo drives

Symbol	Specifications				① Servomotor model	② Servo drive model	
	Voltage	Encoder and Design		Rated Torque			Capacity
①②	1 Phase 200 VAC	Analogue Incremental Encoder	Without brake	0.318 Nm	100 W	SJME-01AMC41-OY	SJDE-01APA-OY
				0.637 Nm	200 W	SJME-02AMC41-OY	SJDE-02APA-OY
				1.27 Nm	400 W	SJME-04AMC41-OY	SJDE-04APA-OY
				2.39 Nm	750 W	SJME-08AMC41-OY	SJDE-08APA-OY
		Straight shaft with key	With brake	0.318 Nm	100 W	SJME-01AMC4C-OY	SJDE-01APA-OY
				0.637 Nm	200 W	SJME-02AMC4C-OY	SJDE-02APA-OY
				1.27 Nm	400 W	SJME-04AMC4C-OY	SJDE-04APA-OY
				2.39 Nm	750 W	SJME-08AMC4C-OY	SJDE-08APA-OY

Power and encoder cables

Note: ③④ Refer to the Junma servo motor section for motor cables or connectors selection

Control cables (for CN1)

Symbol	Name	Compatible units	Model
⑤	Servo relay unit	Units: CS1W-NC113/133, CJ1W-NC113/133, C200HW-NC113	XW2B-20J6-1B (1 axis)
		Units: CS1W-NC213/233/413/433, CJ1W-NC213/233/413/433, C200HW-NC213/413	XW2B-40J6-2B (2 axes)
		Units: CQM1H-PLB21 and CQM1-CPU43-V1	XW2B-20J6-3B (1 axis)
		Use with CJ1M-CPU21/22/23	XW2B-20J6-8A (1 axis)
			XW2B-40J6-9A (2 axes)
⑥	Cable to servo drive	For the servo relay unit XW2B-□□J6-□B, XW2B-20J6-8A, XW2B-40J6-9A	1 m XW2Z-100J-B17 2 m XW2Z-200J-B17
		⑦	Cable to position control unit
CS1W-NC113 and C200HW-NC113	0.5 m XW2Z-050J-A8 1 m XW2Z-100J-A8		
CS1W-NC213/413 and C200HW-NC213/413	0.5 m XW2Z-050J-A9 1 m XW2Z-100J-A9		
CS1W-NC133	0.5 m XW2Z-050J-A12 1 m XW2Z-100J-A12		
CS1W-NC233/433	0.5 m XW2Z-050J-A13 1 m XW2Z-100J-A13		
CJ1W-NC113	0.5 m XW2Z-050J-A16 1 m XW2Z-100J-A16		
CJ1W-NC213/413	0.5 m XW2Z-050J-A17 1 m XW2Z-100J-A17		
CJ1W-NC133	0.5 m XW2Z-050J-A20 1 m XW2Z-100J-A20		
CS1W-NC233/433	0.5 m XW2Z-050J-A21 1 m XW2Z-100J-A21		
CJ1M-CPU21/22/23	0.5 m XW2Z-050J-A26 1 m XW2Z-100J-A26		

Symbol	Name	Compatible units	Model
⑧	Control cable	For general-purpose controllers	1 m R7A-CPZ001S or JZSP-CHI003-01
			2 m R7A-CPZ002S or JZSP-CHI003-02
			3 m JZSP-CHI003-03
⑨	Connector terminal block cable	For general-purpose controllers	1 m XW2Z-100J-B19
			2 m XW2Z-200J-B19
	Connector terminal block		-

Filters

Symbol	Applicable servo drive	Rated current	Leakage current	Rated voltage	Filter model
⑩	SJDE-01APA-OY	5A	1.7 mA	250 VAC 1-phase	R7A-FIZP105-BE
	SJDE-02APA-OY				
	SJDE-04APA-OY				R7A-FIZP109-BE
	SJDE-08APA-OY	9A	1.7 mA		

Regenerative Unit Model (Option)

Symbol	Specifications	Model (Omron)	Model (Yaskawa)
⑪	External regenerative unit (Optional)	R88A-RG08UA	JUSP-RG08D

Connectors

Specification	Model (Omron)	Model (Yaskawa)
Control I/O connector (for CN1)	R7A-CNA01R	JZSP-CHI9-1
Power input connector (for CNB). (Included in drive the box)	R7A-CNZ01P	JZSP-CHG9-1